



**NONRESIDENT  
TRAINING  
COURSE**



March 1993

---

# **Builder 3 & 2, Volume 1**

**NAVEDTRA 14043**

Although the words “he,” “him,” and “his” are used sparingly in this course to enhance communication, they are not intended to be gender driven or to affront or discriminate against anyone.

COMMANDING OFFICER  
NETPDTC  
6490 SAUFLEY FIELD RD  
PENSACOLA, FL 32509-5237

ERRATA #2

7 JUN 1999

Specific Instructions and Errata for  
Nonresident Training Course

BUILDER 3 & 2, VOLUME 1

1. No attempt has been made to issue corrections for errors in typing, punctuation, etc., that do not affect your ability to answer the question or questions.
2. To receive credit for deleted questions, show this errata to your local course administrator (ESO/scorer). The local course administrator is directed to correct the course and the answer key by indicating the questions deleted.
3. Assignment Booklet

Delete the following questions, and leave the corresponding spaces blank on the answer sheets:

Questions

1-50  
2-20  
2-32  
2-45  
2-56  
3-36  
3-53  
3-56  
4-15  
5-17  
7-7  
7-44



## PREFACE

By enrolling in this self-study course, you have demonstrated a desire to improve yourself and the Navy. Remember, however, this self-study course is only one part of the total Navy training program. Practical experience, schools, selected reading, and your desire to succeed are also necessary to successfully round out a fully meaningful training program.

**THE COURSE:** This self-study course is organized into subject matter areas, each containing learning objectives to help you determine what you should learn along with text and illustrations to help you understand the information. The subject matter reflects day-to-day requirements and experiences of personnel in the rating or skill area. It also reflects guidance provided by Enlisted Community Managers (ECMs) and other senior personnel, technical references, instructions, etc., and either the occupational or naval standards, which are listed in the *Manual of Navy Enlisted Manpower Personnel Classifications and Occupational Standards*, NAVPERS 18068.

**THE QUESTIONS:** The questions that appear in this course are designed to help you understand the material in the text.

**VALUE:** In completing this course, you will improve your military and professional knowledge. Importantly, it can also help you study for the Navy-wide advancement in rate examination. If you are studying and discover a reference in the text to another publication for further information, look it up.

*1993 Edition Prepared by  
BUCS John Buza*

Published by  
NAVAL EDUCATION AND TRAINING  
PROFESSIONAL DEVELOPMENT  
AND TECHNOLOGY CENTER

**NAVSUP Logistics Tracking Number  
0504-LP-026-7180**

## **Sailor's Creed**

“I am a United States Sailor.

I will support and defend the Constitution of the United States of America and I will obey the orders of those appointed over me.

I represent the fighting spirit of the Navy and those who have gone before me to defend freedom and democracy around the world.

I proudly serve my country's Navy combat team with honor, courage and commitment.

I am committed to excellence and the fair treatment of all.”

# CONTENTS

CHAPTER	Page
1. Construction Administration and Safety . . . . .	1-1
2. Drawings and Specifications . . . . .	2-1
3. Woodworking Tools, Materials, and Methods . . . . .	3-1
4. Fiber Line, Wire Rope, and Scaffolding . . . . .	4-1
5. Leveling and Grading. . . . .	5-1
6. Concrete . . . . .	6-1
7. Working with Concrete . . . . .	7-1
8. Masonry . . . . .	8-1
9. Planning, Estimating and Scheduling . . . . .	9-1
APPENDIX	
I. Glossary . . . . .	AI- 1
II. References Used to Develop the TRAMAN . . . . .	AII- 1
III. Hand Signals . . . . .	AIII- 1
INDEX . . . . .	INDEX-1

# **SUMMARY OF BUILDER 3&2 RATE TRAINING MANUALS**

## **VOLUME 1**

*Builder 3&2, Volume 1, NAVEDTRA 14043, is a basic book that should be mastered by those seeking advancement to Builder Third Class and Builder Second Class. The major topics addressed in this book include construction administration and safety; drawings and specifications; woodworking tools, materials and methods of woodworking; fiber line, wire rope, and scaffolding; leveling and grading; concrete; placing concrete; masonry; and planning, estimating and scheduling.*

## **VOLUME 2**

*Builder 3&2, Volume 2, NAVEDTRA 14044, continues where Volume 1 ends. The topics covered in Volume 2 include floor and wall construction; roof framing; exterior and interior finishing; plastering, stuccoing, and ceramic tile; paints and preservatives; advanced base field structures; and heavy construction.*



# INSTRUCTIONS FOR TAKING THE COURSE

## ASSIGNMENTS

The text pages that you are to study are listed at the beginning of each assignment. Study these pages carefully before attempting to answer the questions. Pay close attention to tables and illustrations and read the learning objectives. The learning objectives state what you should be able to do after studying the material. Answering the questions correctly helps you accomplish the objectives.

## SELECTING YOUR ANSWERS

Read each question carefully, then select the BEST answer. You may refer freely to the text. The answers must be the result of your own work and decisions. You are prohibited from referring to or copying the answers of others and from giving answers to anyone else taking the course.

## SUBMITTING YOUR ASSIGNMENTS

To have your assignments graded, you must be enrolled in the course with the Nonresident Training Course Administration Branch at the Naval Education and Training Professional Development and Technology Center (NETPDTC). Following enrollment, there are two ways of having your assignments graded: (1) use the Internet to submit your assignments as you complete them, or (2) send all the assignments at one time by mail to NETPDTC.

**Grading on the Internet:** Advantages to Internet grading are:

- you may submit your answers as soon as you complete an assignment, and
- you get your results faster; usually by the next working day (approximately 24 hours).

In addition to receiving grade results for each assignment, you will receive course completion confirmation once you have completed all the

assignments. To submit your assignment answers via the Internet, go to:

**<http://courses.cnet.navy.mil>**

**Grading by Mail:** When you submit answer sheets by mail, send all of your assignments at one time. Do NOT submit individual answer sheets for grading. Mail all of your assignments in an envelope, which you either provide yourself or obtain from your nearest Educational Services Officer (ESO). Submit answer sheets to:

COMMANDING OFFICER  
NETPDTC N331  
6490 SAUFLEY FIELD ROAD  
PENSACOLA FL 32559-5000

**Answer Sheets:** All courses include one “scannable” answer sheet for each assignment. These answer sheets are preprinted with your SSN, name, assignment number, and course number. Explanations for completing the answer sheets are on the answer sheet.

**Do not use answer sheet reproductions:** Use only the original answer sheets that we provide—reproductions will not work with our scanning equipment and cannot be processed.

Follow the instructions for marking your answers on the answer sheet. Be sure that blocks 1, 2, and 3 are filled in correctly. This information is necessary for your course to be properly processed and for you to receive credit for your work.

## COMPLETION TIME

Courses must be completed within 12 months from the date of enrollment. This includes time required to resubmit failed assignments.

## **PASS/FAIL ASSIGNMENT PROCEDURES**

If your overall course score is 3.2 or higher, you will pass the course and will not be required to resubmit assignments. Once your assignments have been graded you will receive course completion confirmation.

If you receive less than a 3.2 on any assignment and your overall course score is below 3.2, you will be given the opportunity to resubmit failed assignments. **You may resubmit failed assignments only once.** Internet students will receive notification when they have failed an assignment--they may then resubmit failed assignments on the web site. Internet students may view and print results for failed assignments from the web site. Students who submit by mail will receive a failing result letter and a new answer sheet for resubmission of each failed assignment.

## **COMPLETION CONFIRMATION**

After successfully completing this course, you will receive a letter of completion.

## **ERRATA**

Errata are used to correct minor errors or delete obsolete information in a course. Errata may also be used to provide instructions to the student. If a course has an errata, it will be included as the first page(s) after the front cover. Errata for all courses can be accessed and viewed/downloaded at:

<http://www.advancement.cnet.navy.mil>

## **STUDENT FEEDBACK QUESTIONS**

We value your suggestions, questions, and criticisms on our courses. If you would like to communicate with us regarding this course, we encourage you, if possible, to use e-mail. If you write or fax, please use a copy of the Student Comment form that follows this page.

## **For subject matter questions:**

E-mail: n314.products@cnet.navy.mil  
Phone: Comm: (850) 452-1001, Ext. 1826  
DSN: 922-1001, Ext. 1826  
FAX: (850) 452-1370  
(Do not fax answer sheets.)  
Address: COMMANDING OFFICER  
NETPDTC (CODE N314)  
6490 SAUFLEY FIELD ROAD  
PENSACOLA FL 32509-5237

## **For enrollment, shipping, grading, or completion letter questions:**

E-mail: fleetservices@cnet.navy.mil  
Phone: Toll Free: 877-264-8583  
Comm: (850) 452-1511/1181/1859  
DSN: 922-1511/1181/1859  
FAX: (850) 452-1370  
(Do not fax answer sheets.)  
Address: COMMANDING OFFICER  
NETPDTC (CODE N331)  
6490 SAUFLEY FIELD ROAD  
PENSACOLA FL 32559-5000

## **NAVAL RESERVE RETIREMENT CREDIT**

If you are a member of the Naval Reserve, you will receive retirement points if you are authorized to receive them under current directives governing retirement of Naval Reserve personnel. For Naval Reserve retirement, this course is evaluated at 12 points. (Refer to *Administrative Procedures for Naval Reservists on Inactive Duty*, BUPERSINST 1001.39, for more information about retirement points.)

## **COURSE OBJECTIVES**

In completing this nonresident training course, you will demonstrate a knowledge of the subject matter by correctly answering questions on the following: construction administration and safety; drawings and specifications; woodworking tools, materials, and methods; fiber line, wire rope, and scaffolding; leveling and grading; concrete; working with concrete; masonry; and planning, estimating, and scheduling.

## Student Comments

**Course Title:** Builder 3 & 2, Volume 1

**NAVEDTRA:** 14043 **Date:** \_\_\_\_\_

**We need some information about you:**

Rate/Rank and Name: \_\_\_\_\_ SSN: \_\_\_\_\_ Command/Unit \_\_\_\_\_

Street Address: \_\_\_\_\_ City: \_\_\_\_\_ State/FPO: \_\_\_\_\_ Zip \_\_\_\_\_

**Your comments, suggestions, etc.:**

**Privacy Act Statement:** Under authority of Title 5, USC 301, information regarding your military status is requested in processing your comments and in preparing a reply. This information will not be divulged without written authorization to anyone other than those within DOD for official use in determining performance.

NETPDTC 1550/41 (Rev 4-00)



# CHAPTER 1

## CONSTRUCTION ADMINISTRATION AND SAFETY

Being a petty officer carries many inherent responsibilities. These include your personal obligation to be a leader, an instructor, and an administrator in all the areas of your rating-military, technical, and safety.

As a petty officer, you need to develop an ability to control the work performed by your workers, as well as to lead them. As you gain experience as a petty officer and increase your technical competence as a Builder, you begin to accept a certain amount of responsibility for the work of others. With each advancement, you accept an increasing responsibility in military matters and in matters relating to the professional work of your rate. As you advance to third class and then to second class petty officer, you not only will have increased privileges but also increased responsibilities. You begin to assume greater supervisory and administrative positions.

The proper administration of any project, large or small, is as important as the actual construction. This chapter will provide you with information to help you to use and prepare the administrative paperwork that you encounter as a crew leader or as a crewmember.

### ADMINISTRATION

*LEARNING OBJECTIVE: Upon completing this section, you should be able to identify crew leader responsibilities in preparing tool kit inventories, preparing supply requisitions, and submitting labor time cards.*

Administration is the means a person or an organization uses to keep track of what's happening. It provides a means of telling others what's been done and planned, who's doing it, and what's needed. Administration ranges from a simple notebook kept in your pocket to filling out a variety of reports and forms. As a growing leader in the Navy, you must learn about and become effective in the use of both the tools of your trade and administrative tools. Once you become comfortable with these, you can be a successful administrator.

### PLANNING WORK ASSIGNMENTS

For our purposes here, planning means the process of determining requirements and developing methods and schemes of action for performing a task. Proper planning saves time and money and ensures a project is completed in a professional manner. Here, we'll look at some, but not all, of the factors you need to consider.

When you get a project, whether in writing or orally, make sure you clearly understand what is to be done. Study the plans and specifications carefully. If you have any questions, find the answers from those in a position to supply the information you need. Also, make sure you understand the priority of the project, expected time of completion, and any special instructions.

Consider the capabilities of your crew. Determine who is to do what and how long it should take. Also, consider the tools and equipment you will need. Arrange to have them available at the jobsite at the time the work is to get under way. Determine who will use the tools and make sure they know how to use them properly and safely.

To help ensure that the project is completed properly and on time, determine the best method of getting it done. If there is more than one way of doing a particular assignment, you should analyze the methods and select the one most suited to the job conditions. Listen to suggestions from others. If you can simplify a method and save time and effort, do it.

Establish goals for each workday and encourage your crew to work as a team in meeting these goals. Set goals that keep your crew busy, but make sure they are realistic. Discuss the project with the crew so they know what you expect from them. During an emergency, most crewmembers will make an all-out effort to meet a deadline. But when there is no emergency, don't expect them to work continuously at an excessively high rate. Again, set realistic goals. Daily briefings of this type cannot be over-emphasized.

## **DIRECTING WORK TEAMS**

After a job has been properly planned, it is necessary to carefully direct the job. This ensures it is completed on time and with the quality that satisfies both the customer and the crew.

Before starting a project, make sure the crew knows what is expected. Give instructions and urge the crew to ask questions on all points that are not clear. Be honest in your answers. If you don't have an answer, say so; then find the answer and get back to the crew. Don't delay in getting solutions to the questions asked. Timely answers keep projects moving forward. They also show the crew your concern for the project is as genuine as theirs.

While a job is under way, spot check to ensure that the work is progressing satisfactorily. Determine whether the proper methods, materials, tools, and equipment are being used. When determining the initial requirements, do so early enough so there are no delays. If crewmembers are incorrectly performing a task, stop them and point out the correct procedures. When you check crewmembers' work, make them feel the purpose of checking is to teach, guide, or direct—not to criticize or find fault.

Make sure the crew complies with applicable safety precautions and wear safety apparel when required. Watch for hazardous conditions, improper use of tools and equipment, and unsafe work practices. These can cause mishaps and possibly result in injury to personnel. There are no excuses for unsafe practices. Proper safety instructions and training eliminate the desire to work carelessly. When directing construction crews, practice what you preach.

When time permits, rotate crewmembers on various jobs. Rotation gives you the opportunity to teach. It also gives each crewmember an opportunity to increase personal skill levels.

As a crew leader, you need to ensure that your crew work together in getting the job done. Develop an environment where each crewmember feels free to seek your advice when in doubt about any phase of the work. Emotional balance is especially important. Don't panic in view of your crew or be unsure of yourself when faced with a conflict.

Be tactful and courteous in dealing with your crew. It sounds obvious, but don't show any partiality. Keep every crewmember informed on both work and personal matters that affect his or her

performance. Also, try to maintain a high level of morale. Low morale has a definite effect on the quantity and quality of a crew's work.

As you advance in rate, you spend more and more time supervising others. You have to learn as much as you can about supervision. Study books on both supervision and leadership. Also, watch how other supervisors—both good and bad—operate. Don't be afraid to ask questions.

## **TOOL KIT INVENTORY**

Tool kits contain all the craft hand tools required by one, four-member construction crew or fire team of a given rating to pursue their trade. The kits may contain additional items required by a particular assignment. However, they should not be reduced in type of item and should be maintained at 100 percent of kit assembly allowance at all times.

As a crew leader, you can order and are responsible for all the tools required by the crew. This incurs the following responsibilities:

- Maintaining complete tools kits at all times;
- Assigning tools within the crew;
- Ensuring proper use and care of assigned tools by the crew;
- Preserving tools not in use;
- Securing assigned tools; and
- Ensuring that all electrical tools and cords are inspected on a regular basis.

To make sure tools are maintained properly, the operations officer and the supply officer establish a formal tool kit inventory and inspection program. As a crew leader, you perform a tool kit inventory at least every 2 weeks. Tools requiring routine maintenance are turned in to the central tool room (CTR) for repair and reissue. Damaged or worn tools should be returned to the CTR for replacement. You must submit requisitions for replacement items.

Tool management is further specified in instructions issued by Commander, Construction Battalion, Pacific (COMCBPAC) and Commander, Construction Battalion, Atlantic (COMCBLANT).

## PREPARING REQUISITIONS

As a crew leader, you must become familiar with the forms used to request material or services through the Navy Supply System. Printed forms are available that provide all the information necessary for the physical transfer of the material and accounting requirements. The form you will use most often is NAVSUP Form 1250, shown in figure 1-1.

Crew leaders are not usually required to complete the entire form. However, you must list the stock number of the item, when available, the quantity required, and the name or description of each item needed. Turn this form in to the expeditor, who checks it, fills in the remaining information, and signs it. The form then goes to the material liaison officer (MLO) or supply department for processing.

In ordering material, you need to know about the national stock number (NSN) system. Information on the NSN system and other topics about supply is given in *Military Requirements for Petty Officer Third Class*, NAVEDTRA 12044.

## TIMEKEEPING

In both battalion and shore-based activities, you will be posting entries on time cards for military

personnel. You need to know the type of information called for on the cards and understand the importance of accuracy in labor reporting. The reportings systems used primarily in naval mobile construction battalions (NMCBs) and the system employed at shore-based activities are similar.

A labor accounting system is used to record and measure the number of man-hours a unit spends on various functions. Labor utilization information is collected every day in sufficient detail and manner to allow the operations department to readily compile the data. This helps the operations officer to both manage manpower resources and prepare reports for higher authority. Although labor accounting systems may vary slightly from one command to another, the system described here is typical.

Each work unit accounts for all labor used to carry out its assignment. This lets management determine the amount of labor used on the project. Labor costs are figured, and actual man-hours are compared with other similar jobs. When completed, unit managers and higher commands use this information to develop planning standards.

The type of labor performed must be broken down and reported by category to show how labor has been used. For timekeeping and labor reporting

1 REQ DATE	2 DEPT. NO.	3 URGY	4 ROD	5 LOCATION	6 <input type="checkbox"/> RM <input type="checkbox"/> NON-RM	7 ISSUE DATE	A. REON. QTY.	B REON. NO
8 NOUN NAME OR REF SYM		9 FPR <input type="checkbox"/>	10 APL/AEL/CID		11 INV. QTY.	12 <input type="checkbox"/> NIS <input type="checkbox"/> N/C	C. OBL. AMT.	D. POSTED
JOB CONTROL NUMBER				16 EIC	17. EQUIP COSAL SUPPT'D		E. URG <input type="checkbox"/> MART <input type="checkbox"/>	S/R (REON O/S)
13 UIC	14 WC	15 JSN			YES <input type="checkbox"/> NO <input type="checkbox"/>	PROJ	OPTAR LOG	S/R (ISSUE)
18 SC	19 COG	20 MCC	STOCK NUMBER		24 U/I	25 QUANTITY	26 UNIT PRICE	27. EXTENDED PRICE
			21 FSC	22 NIIN	23 SMIC			28. FUND
29 REMARKS						30. APPROVED BY:		
						31. RECEIVED BY:		

SAMPLE LINE ITEM CONSUMPTION DOCUMENT (MANUAL)  
NAVSUP FORM 1250 (9 P) (REV 7/78) S/N 0108 (7-50) 500

Figure 1-1.—NAVSUP 1250.

purposes, all labor is classified as either productive or overhead. Labor codes are shown in figure 1-2.

Productive labor either directly or indirectly contributes to the completion of the unit's mission, including construction operations and training. It is broken down into four categories: direct labor, indirect labor, military operations and readiness, and training.

Direct labor includes labor expended directly on assigned construction tasks contributing directly to the completion of an end product. It can be either in the field or in the shop. Direct labor must be reported separately for each assigned construction task. Indirect labor is labor required to support construction operations but not producing an end product itself.

Military operations and readiness includes work necessary to ensure the unit's military and mobility

readiness. It consists of all manpower expended in actual military operations, unit embarkation, and planning and preparations.

Training includes attendance at service schools, factory and industrial courses, fleet-level training and short courses, military training, and organized training conducted within the battalion or unit.

Overhead labor, compared to productive labor, does not contribute directly or indirectly to the completion of an end product. It includes labor that must be performed regardless of the assigned mission.

During project planning and scheduling, each direct labor phase of the project is given an identifying code. For example, excavating and setting forms may be assigned code R-15; laying block, code R-16; and installing bond beams, code R-17. (Since there are many types of construction

<p><b>PRODUCTIVE LABOR.</b> Productive labor includes all labor that directly contributes to the accomplishment of the Naval Mobile Construction Battalion (NMCB), including construction operations and readiness, disaster recovery operations, and training.</p>		
<p><b>DIRECT LABOR.</b> This category includes all labor expended directly on assigned construction tasks, either in the field or in the shop, and which contributes directly to the completion of the end product.</p>		
<p><b>INDIRECT LABOR.</b> This category comprises labor required to support construction operations, but which does not produce in itself. Indirect labor reporting codes are as follows:</p>		
X01 Construction Equipment Maintenance, Repair and Records	X04 Project Expediting (Shop Planners)	X07 Tool and Spare Parts Issue
X02 Operation and Engineering	X05 Location Moving	X08 Other
X03 Project Supervision	X06 Project Material Support	
<p><b>MILITARY OPERATIONS AND READINESS.</b> This category comprises all manpower expended in actual military operations, unit embarkation, and planning and preparations necessary to insure unit military and mobility readiness. Reporting codes are as follows:</p>		
M01 Military Operations	M04 Unit Movement	M07 Military Administrative Functions
M02 Military Security	M05 Mobility Preparation	M08 Mobility & Defense Exercise
M03 Embarkation	M06 Contingency	M09 Other
<p><b>DISASTER CONTROL OPERATIONS</b></p>		
D01 Disaster Control Operations	D02 Disaster Control Exercise	
<p><b>TRAINING.</b> This category includes attendance at service schools, factory, and industrial training courses, fleet type training, and short courses, military training, and organized training conducted within the battalion. Reporting codes are as follows:</p>		
T01 Technical Training	T03 Disaster Control Training	T05 Safety Training
T02 Military Training	T04 Leadership Training	T06 Training Administration
<p><b>OVERHEAD LABOR.</b> This category includes labor that must be performed regardless of whether a mission is assigned, and which does not contribute to the assigned mission. Reporting codes are as follows:</p>		
Y01 Administrative & Personnel	Y06 Camp Upkeep & Repairs	Y10 Personal Affairs
Y02 Medical & Dental Department	Y07 Security	Y11 Lost Time
Y03 Navy Exchange and Special Services	Y08 Leave & Liberty	Y12 TAD not for unit
Y04 Supply & Disbursing	Y09 Sickcall, Dental & Hospitalization	Y13 Other
Y05 Commissary		

Figure 1-2.—Labor codes.





distribution of total manpower resources for each day. It also serves as feeder information for preparing the monthly operations report, and any other source reports required of the unit. The information must be accurate and timely. Each level in the organization should review the report for an analysis of its own internal construction management and performance.

### SAFETY PROGRAM

*LEARNING OBJECTIVE: Upon completing this section, you should be able to describe the safety organization, function of the battalion or unit safety program, and the responsibilities of key personnel.*

You must be familiar with the safety program at your activity. You cannot function effectively as a petty officer unless you are aware of how safety fits into your organization. You need to know who establishes and arbitrates safety policies and procedures. You should also know who provides guidelines for safety training and supervision. Every NMCB and shore command has a formal safety organization.

### SAFETY ORGANIZATION

The NMCB's safety organization provides for the establishment of safety policy and control and reporting. As illustrated in figure 1-4, the battalion safety policy organization contains several committees: policy; supervisors'; and equipment, shop, and crew.

The executive officer presides over the safety policy committee. Its primary purpose is to develop safety rules and policy for the battalion. This committee reports to the commanding officer, who approves all changes in safety policy.

The battalion safety officer presides over the safety supervisors' committee. This committee includes safety supervisors assigned by company commanders, project officers, or officers in charge of a detail. Basically, it helps the safety officer manage an effective overall safety and health program. The committee provides a convenient forum for work procedures, safe practices, and safety suggestions. Its recommendations are sent to the policy committee.

The equipment, shop, and crew committees are assigned as required and are usually presided over by the company or project safety supervisor. The main

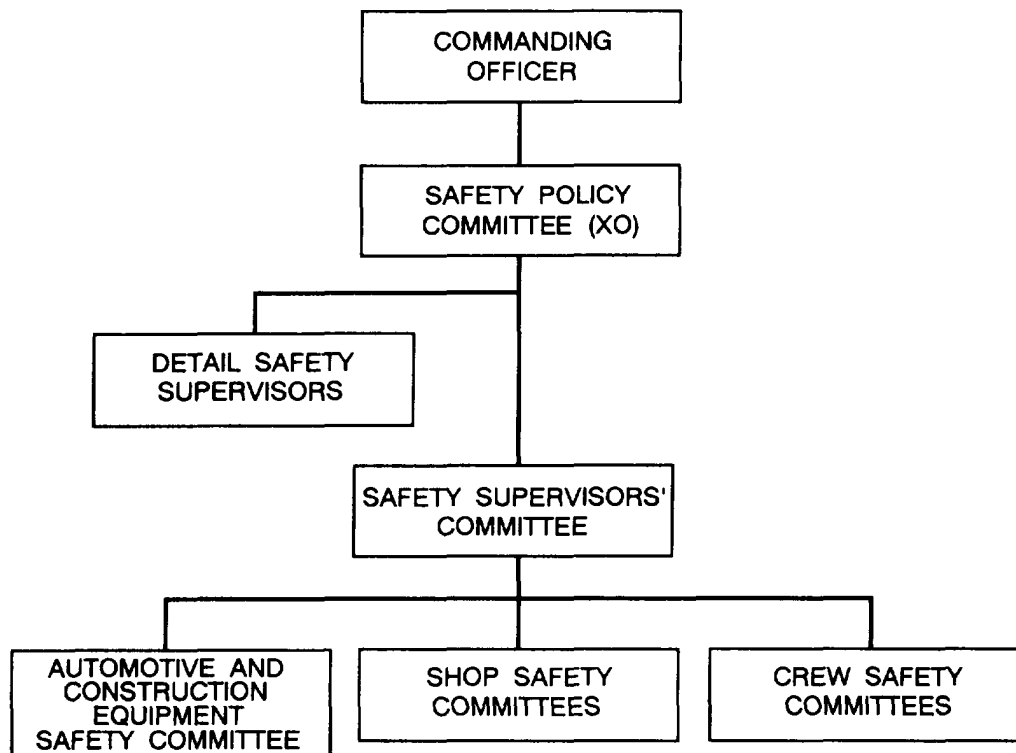

Figure 1-4.—NMCB safety policy organization.

objective of this committee is to propose changes in the battalion's safety policy to eliminate unsafe working conditions or prevent unsafe acts. It is your contact for recommending changes in safety matters. In particular, the equipment committee reviews all vehicle mishap reports, determines the cause of each mishap, and recommends corrective action. As a crew leader, you can expect to serve as a member. Each committee forwards reports and recommendations to the safety supervisors' committee.

## **SAFETY DUTIES**

As a crew leader, you will report to the safety supervisor, who directs the safety program of a project. The safety supervisor is inherently responsible for all personnel assigned to that shop or project. Some of the duties include indoctrinating new crewmembers, compiling mishap statistics for the project, reviewing mishap reports submitted to the safety office, and comparing safety performances of all crews.

The crew leader is responsible for carrying out safe working practices. This is done under the direction of the safety supervisor or others in positions of authority (project chief, project officer, or safety officer). You, as the crew leader, ensure that each crewmember is thoroughly familiar with these working practices, has a general understanding of pertinent safety regulations, and makes proper use of protective clothing and safety equipment. Furthermore, you should be ready at all times to correct every unsafe working practice you observe, and report it immediately to the safety supervisor or the person in charge. When an unsafe condition exists, any crew or shop member can stop work until the condition is corrected.

In case of a mishap, make sure injured personnel get proper medical care as quickly as possible. Investigate each mishap involving crewmembers to determine its cause. Remove or permanently correct defective tools, materials, and machines. Do the same for environmental conditions contributing to a mishap. Afterward, submit required reports.

## **SAFETY TRAINING**

New methods and procedures for safely maintaining and operating equipment are always coming out. You must keep up to date on the latest techniques in maintenance and operation safety and pass them on to your crewmembers. One method of

keeping your crewmembers informed is by holding stand-up safety meetings before the day's work starts. As crew leader, you are responsible for conducting each meeting and passing on material from the safety supervisor, Information (such as the type of safety equipment to use, where to obtain it, and how to use it) is often the result of safety suggestions received by the safety supervisors' committee. Encourage your crew to submit ideas or suggestions. Don't limit yourself to just the safety lecture in the morning. Discuss minor safety infractions when they occur or at appropriate break times during the day. As the crew leader, you must impress safe working habits upon your crewmembers through proper instructions, constant drills, and continuous supervision.

You may hold group discussions on **specific mishaps** to guard against or that may happen on the job. Be sure to give plenty of thought to what you are going to say beforehand. Make the discussion interesting and urge the crew to participate. The final result should be a group conclusion as to how the specific mishap can be prevented.

Your stand-up safety meetings also give you the chance to discuss prestart checks, and the operation or maintenance of automotive vehicles assigned to a project. Vehicles are used for transporting crewmembers as well as cargo. It is important to emphasize how the prestart checks are to be made and how to care for the vehicles.

You can use a stand-up safety meeting to solve safety problems arising from a new procedure. An example might be starting a particular piece of equipment just being introduced. In this case, show the safe starting procedure for the equipment. Then, have your crewmembers practice the procedure.

Because of the variety of vehicles that may be assigned to a project, there is too much information and too many operating procedures for one person to remember. You need to know where to look for these facts and procedures. For specific information on prestart checks, operation, and maintenance of each vehicle assigned, refer to the manufacturer's operator/maintenance manuals. In addition, personnel from Alfa Company (equipment experts) will instruct all personnel in the proper start-up procedures for new equipment.

In addition to stand-up safety meetings, conduct day-to-day instruction and on-the-job training. Although it is beyond the scope of this chapter to describe teaching methods, a few words on your

approach to safety and safety training at the crew level are appropriate. Getting your crew to work safely, like most other crew leader functions, is essentially a matter of leadership. Therefore, don't overlook the power of **personal example** in leading and teaching your crewmembers. They are quick to detect differences between what you say and what you do. Don't expect them to measure up to a standard of safe conduct that you, yourself, do not. Make your genuine concern for the safety of your crew visible at all times. Leadership by example is one of the most effective techniques you can use.

## RECOMMENDED READING LIST

### NOTE

Although the following references were current when this TRAMAN was published,

their continued currency cannot be assured. You therefore need to ensure that you are studying the latest revision.

*Naval Construction Force Manual*, P-315, Naval Facilities Engineering Command, Washington, D.C., 1985.

*Naval Construction Force Occupational Safety and Health Program Manual*, COMCBPAC/COMCBLANTINST 5100.1F, Commander, Naval Construction Battalions, U.S. Pacific Fleet, Pearl Harbor, Hawaii, and Commander, Naval Construction Battalions, U.S. Atlantic Fleet, Naval Amphibious Base, Little Creek, Norfolk, Va., 1991.

*Seabee Planner's Estimator Handbook*, NAVFAC P-405, Naval Facilities Engineering Command, Alexandria, Va., 1983.

## CHAPTER 2

# DRAWINGS AND SPECIFICATIONS

By this time in your Navy career, you have probably worked as a crewmember on various building projects. You probably did your tasks without thinking much about what it takes to lay out structures so they will conform to their location, size, shape, and other building features. In this chapter, you will learn how to extract these types of information from drawings and specifications. You will also be shown how to draw, read, and work from simple shop drawings and sketches.

We provide helpful references throughout the chapter. You are encouraged to study these, as required, for additional information on the topics discussed.

### DESIGN OF STRUCTURAL MEMBERS

*LEARNING OBJECTIVE: Upon completing this section, you should be able to identify the different types of structural members.*

From the Builder's standpoint, building designs and construction methods depend on many factors. No two building projects can be treated alike. However, the factors usually considered before a structure is designed are its geographical location and the availability of construction materials.

It is easy to see why geographical location is important to the design of a structure, especially its main parts. When located in a temperate zone, for example, the roof of a structure must be sturdy enough not to collapse under the weight of snow and ice. Also, the foundation walls have to extend below the frost line to guard against the effects of freezing and thawing. In the tropics, a structure should have a low-pitch roof and be built on a concrete slab or have shallow foundation walls.

Likewise, the availability of construction materials can influence the design of a structure. This happens when certain building materials are scarce in a geographical location and the cost of shipping them is prohibitive. In such a case, particularly overseas, the structure is likely to be built with materials purchased locally. In turn, this can affect the way construction materials are used—it means working

with foreign drawings and metric units of weights and measures.

By comparing the designs of the two structures shown in figures 2-1 and 2-2, you can see that each is designed according to its function. For example, light-frame construction is usually found in residential buildings where a number of small rooms are desired. Concrete masonry and steel construction is used for warehouse-type facilities where large open spaces are needed. You should study these figures carefully and learn the terminology. Depending on the use of the structure, you may use any combination of structural members.

### DEAD AND LIVE LOADS

The main parts of a structure are the load-bearing members. These support and transfer the loads on the structure while remaining equal to each other. The places where members are connected to other members are called joints. The sum total of the load supported by the structural members at a particular instant is equal to the total dead load plus the total live load.

The total dead load is the total weight of the structure, which gradually increases as the structure rises and remains constant once it is completed. The total live load is the total weight of movable objects (such as people, furniture, and bridge traffic) the structure happens to be supporting at a particular instant.

The live loads in a structure are transmitted through the various load-bearing structural members to the ultimate support of the earth. Immediate or direct support for the live loads is first provided by horizontal members. The horizontal members are, in turn, supported by vertical members. Finally, the vertical members are supported by foundations or footings, which are supported by the earth. Look at figure 2-1, which illustrates both horizontal and vertical members of a typical light-frame structure. The weight of the roof material is distributed over the top supporting members and transferred through all joining members to the soil.

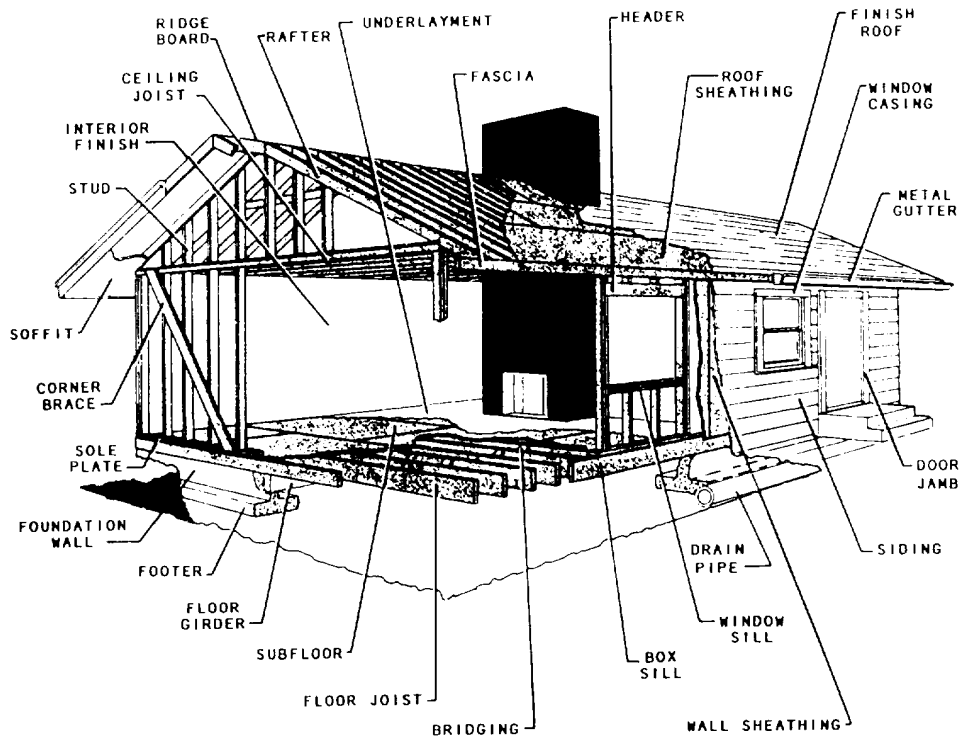

Figure 2-1.—Typical light-frame construction.

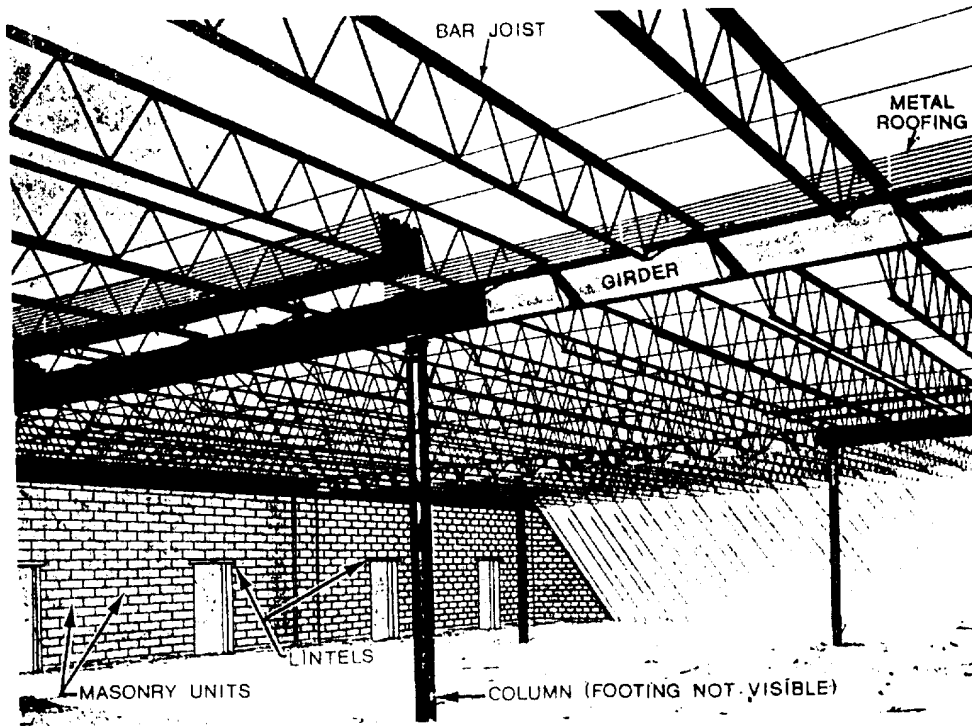

Figure 2-2.—Typical concrete masonry and steel structure.

The ability of the earth to support a load is called its soil-bearing capacity. This varies considerably with different types of soil. A soil of a given bearing capacity bears a heavier load on a wide foundation or footing than on a narrow one.

### VERTICAL STRUCTURAL MEMBERS

In heavy construction, vertical structural members are high-strength columns. (In large buildings, these are called pillars.) Outside wall columns and inside bottom-floor columns usually rest

directly on footings. Outside wall columns usually extend from the footing or foundation to the roof line. Inside bottom-floor columns extend upward from footings or foundations to the horizontal members, which, in turn, support the first floor or roof, as shown in figure 2-2. Upper floor columns are usually located directly over lower floor columns.

In building construction, a pier, sometimes called a short column, rests either directly on a footing, as shown in the lower center of figure 2-3, or is simply set or driven into the ground. Building piers usually support the lowermost horizontal structural members.

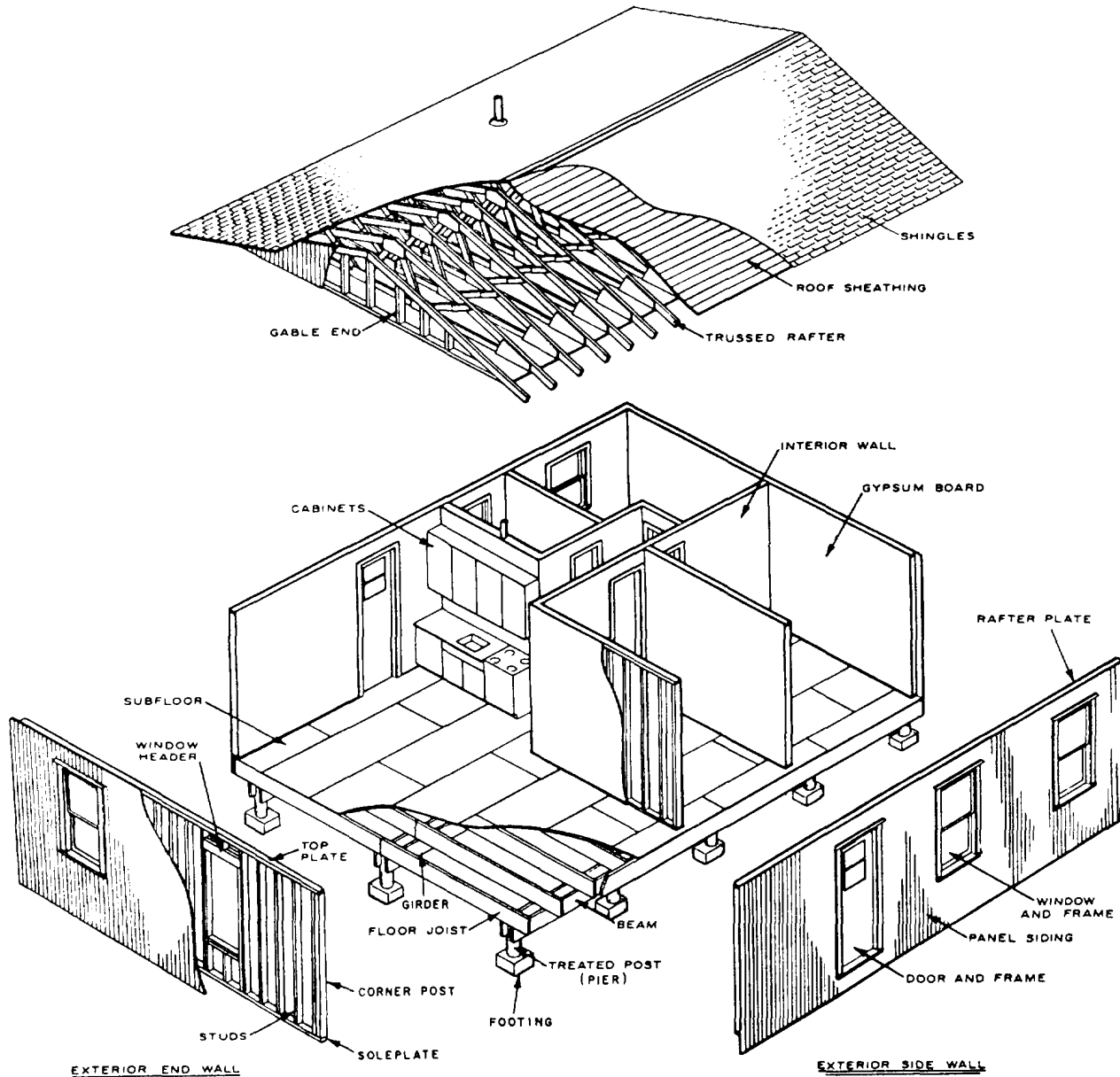

Figure 2-3.—Exploded view of a typical light-frame house.

In bridge construction, a pier is a vertical member that provides intermediate support for the bridge superstructure.

The chief vertical structural members in light-frame construction are called studs (see figures 2-1 and 2-3). They are supported by horizontal members called sills or soleplates, as shown in figure 2-3. Corner posts are enlarged studs located at the building corners. Formerly, in full-frame construction, a corner post was usually a solid piece of larger timber. In most modern construction, though, built-up corner posts are used. These consist of various members of ordinary studs nailed together in various ways.

## HORIZONTAL STRUCTURAL MEMBERS

Technically, any horizontal load-bearing structural member that spans a space and is supported at both ends is considered a beam. A member fixed at one end only is called a cantilever. Steel members that consist of solid pieces of regular structural steel are referred to as "structural shapes." A girder (shown in figure 2-2) is a structural shape. Other prefabricated, open-web, structural-steel shapes are called bar joists (also shown in figure 2-2).

Horizontal structural members that support the ends of floor beams or joists in wood-frame construction are called sills or girders see figures 2-1 and 2-3). The name used depends on the type of framing and the location of the member in the structure. Horizontal members that support studs are called soleplates, depending on the type of framing. Horizontal members that support the wall ends of rafters are called rafter plates. Horizontal members that assume the weight of concrete or masonry walls above door and window openings are called lintels (figure 2-2).

The horizontal or inclined members that provide support to a roof are called rafters (figure 2-1). The lengthwise (right angle to the rafters) member, which supports the peak ends of the rafters in a roof, is called the ridge. The ridge may be called a ridge board, the ridge piece, or the ridge pole. Lengthwise members other than ridges are called purlins. In wood-frame construction, the wall ends of rafters are supported on horizontal members called rafter plates, which are, in turn, supported by the outside wall studs. In concrete or masonry wall construction, the wall ends of rafters may be anchored directly on the walls or on plates bolted to the walls.

A beam of given strength, without intermediate supports below, can support a given load over only a specific maximum span. When the span is wider than this maximum space, intermediate supports, such as columns, must be provided for the beam. Sometimes it is either not feasible or impossible to increase the beam size or to install intermediate supports. In such cases, a truss is used. A truss is a combination of members, such as beams, bars, and ties, usually arranged in triangular units to form a rigid framework for supporting loads over a span.

The basic components of a roof truss are the top and bottom chords and the web members. The top chords serve as roof rafters. The bottom chords act as ceiling joists. The web members run between the top and bottom chords. The truss parts are usually made of 2- by 4-inch or 2- by 6-inch material and are tied together with metal or plywood gusset plates, as shown in figure 2-4.

Roof trusses come in a variety of shapes and sizes. The most commonly used roof trusses, shown in figure 2-5, for light-frame construction are the king-post, the W-type, and the scissors trusses. The simplest type of truss used in frame construction is the king-post truss. It is mainly used for spans up to 22 feet. The most widely used truss in light-frame construction is the W-type truss. The W-type truss can be placed over spans up to 50 feet. The scissors truss is used for buildings with sloping ceilings. Generally, the slope of the bottom chord equals one-half the slope of the top chord. It can be placed over spans up to 50 feet.

## DRAWINGS

*LEARNING OBJECTIVE: Upon completing this section, you should be able to recognize the different types of drawings and their uses.*

The building of any structure is described by a set of related drawings that give the Builder a complete, sequential, graphic description of each phase of the construction process. In most cases, a set of drawings begins by showing the location, boundaries, contours, and outstanding physical features of the construction site and its adjoining areas. Succeeding drawings give instructions for the excavation and disposition of existing ground; construction of the foundations and superstructure; installation of utilities, such as plumbing, heating, lighting, air conditioning, interior and exterior finishes; and whatever else is required to complete the structure.



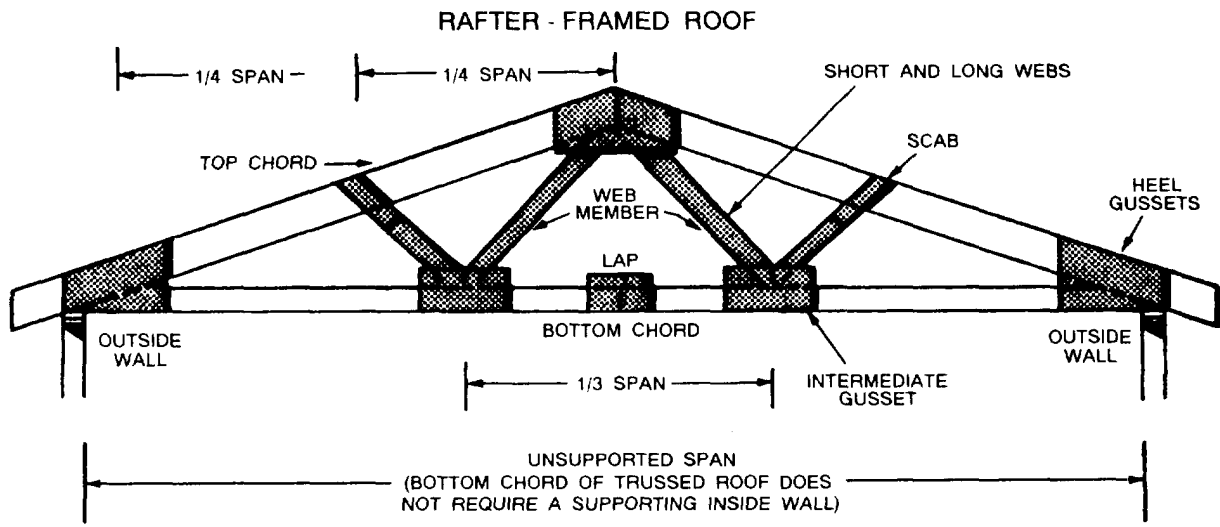

Figure 2-4.—A truss rafter.

The engineer works with the architect to decide what materials to use in the structure and the construction methods to follow. The engineer determines the loads that supporting members will carry and the strength qualities the members must have to bear the loads. The engineer also designs the mechanical systems of the structure, such as the lighting, heating, and plumbing systems. The end result is the architectural and engineering design sketches. These sketches guide draftsmen in preparing the construction drawings.

### CONSTRUCTION DRAWINGS

Generally, construction or “working” drawings furnish enough information for the Builder to complete an entire project and incorporate all three main groups of drawings—architectural, electrical, and mechanical. In drawings for simple structures, this grouping may be hard to discern because the same single drawing may contain both the electrical and mechanical layouts. In complicated structures, however, a combination of layouts is not possible because of overcrowding. In this case, the floor plan may be traced over and over for drawings for the electrical and mechanical layouts.

All or any one of the three types of drawings gives you enough information to complete a project. The specific one to use depends on the nature of construction involved. The construction drawing furnishes enough information for the particular tradesman to complete a project, whether architectural, electrical, or mechanical. Normally, construction drawings include the detail drawings, assembly drawings, bill of materials, and the specifications.

A detail drawing shows a particular item on a larger scale than that of the general drawing in which the item appears. Or, it may show an item too small to appear at all on a general drawing.

An assembly drawing is either an exterior or sectional view of an object showing the details in the proper relationship to one another. Assembly drawings are usually drawn to a smaller scale from the dimensions of the detail drawings. This provides a check on the accuracy of the design drawings and often discloses errors.

Construction drawings consist mostly of right-angle and perpendicular views prepared by draftsmen

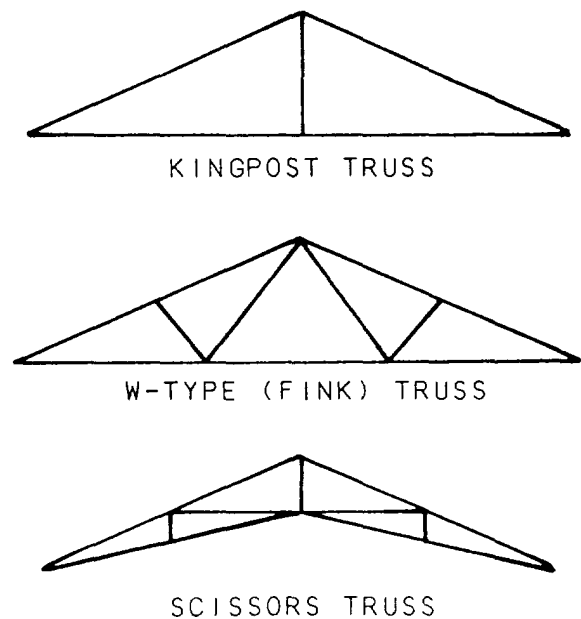

Figure 2-5.—The most commonly used roof trusses.

using standard technical drawing techniques, symbols, and other designations as stated in military standards (MIL-STDS). The first section of the construction drawings consists of the site plan, plot plan, foundation plans, floor plans, and framing plans. General drawings consist of plans (views from above) and elevations (side or front views) drawn on a

relatively small scale. Both types of drawings use a standard set of architectural symbols. Figure 2-6 illustrates the conventional symbols for the more common types of material used on structures. Figure 2-7 shows the more common symbols used for doors and windows. Study these symbols thoroughly before proceeding further in this chapter.

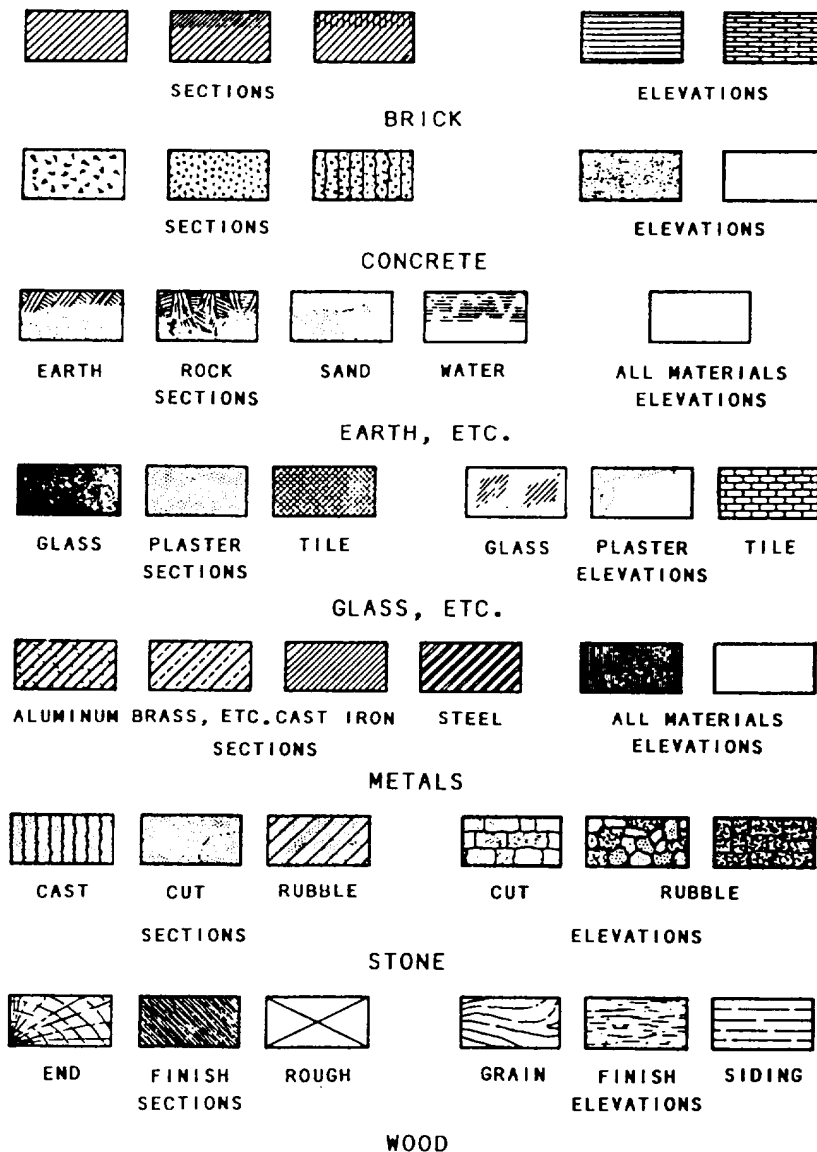

Figure 2-6.-Architectural symbols for plans and elevations.

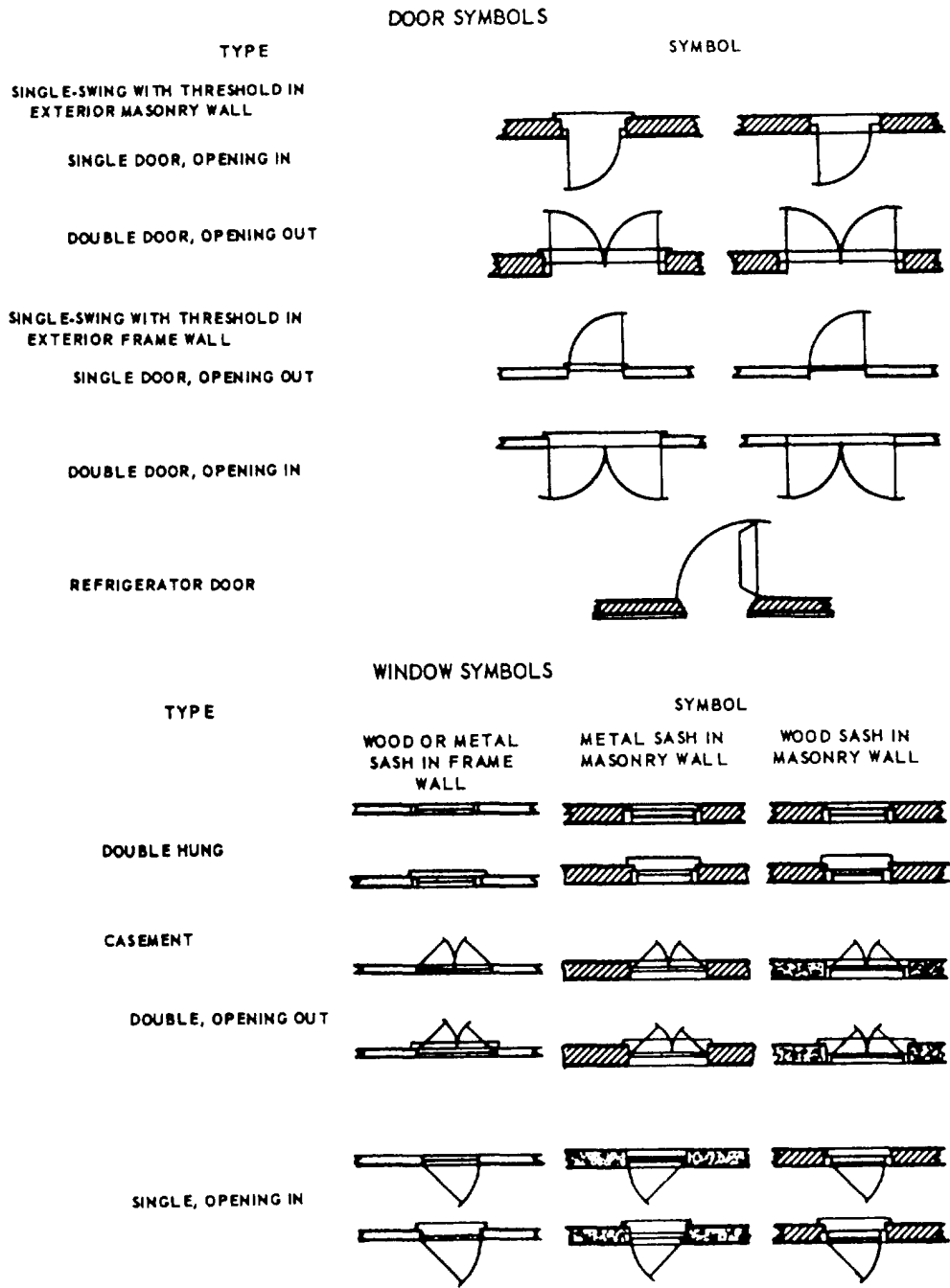

Figure 2-7.—Architectural symbols for doors and windows.

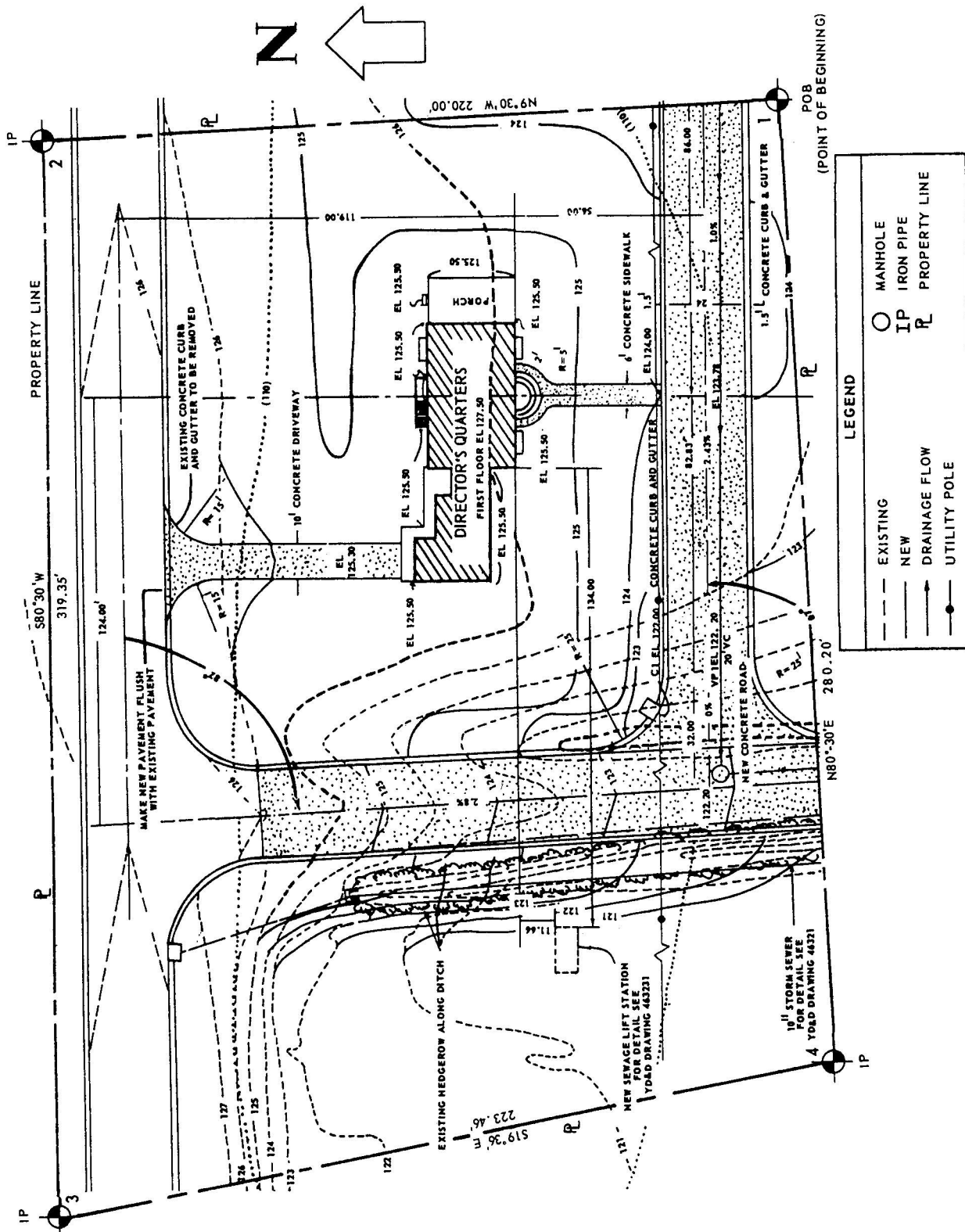

Figure 2-8.—Site plan.

## Site Plan

A site plan (figure 2-8) shows the contours, boundaries, roads, utilities, trees, structures, and any other significant physical features on or near the construction site. The locations of proposed structures are shown in outline. This plan shows corner locations with reference to reference lines shown on the plot that can be located at the site. By showing both existing and finished contours, the site plan furnishes essential data for the graders.

## Plot Plan

The plot plan shows the survey marks with the elevations and the grading requirements. The plot plan is used by the Engineering Aids to set up the corners and perimeter of the building using batter boards and line stakes, as shown in figure 2-9. Thus, the plot plan furnishes the essential data for laying out the building.

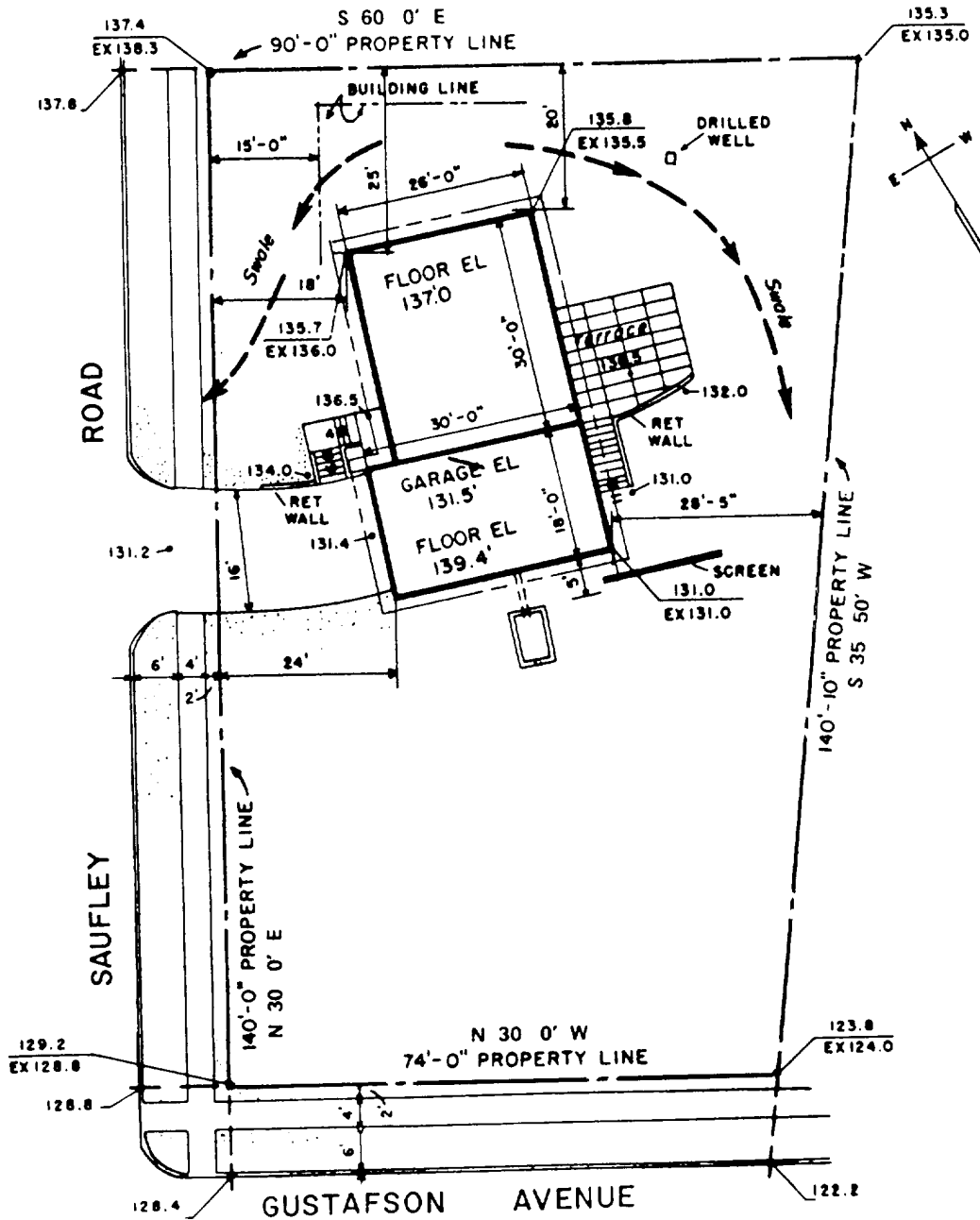

Figure 2-9.—Plot plan.

## Foundation Plan

A foundation plan is a plane view of a structure. That is, it looks as if it were projected onto a horizontal plane and passed through the structure. In the case of the foundation plan, the plane is slightly below the level of the top of the foundation wall. The plan in figure 2-10 shows that the main foundation consists of 12-inch and 8-inch concrete masonry unit (CMU) walls measuring 28 feet lengthwise and 22 feet crosswise. The lower portion of each lengthwise section of wall is to be 12 inches thick to provide a concrete ledge 4 inches wide.

A girder running through the center of the building will be supported at the ends by two 4-by-12-inch concrete pilasters butting against the end foundation walls. Intermediate support for the girder will be provided by two 12-by-12-inch

concrete piers, each supported on 18-by-18-inch spread footings, which are 10 inches deep. The dotted lines around the foundation walls indicate that these walls will also rest on spread footings.

## Floor Plan

Figure 2-11 shows the way a floor plan is developed: from elevation, to cutting plane, to floor plan. An architectural or structural floor plan shows the structural characteristics of the building at the level of the plane of projection. A mechanical floor plan shows the plumbing and heating systems and any other mechanical components other than those that are electrical. An electrical floor plan shows the lighting system and any other electrical systems.

Figure 2-12 is a floor plan showing the lengths, thicknesses, and character of the outside walls and

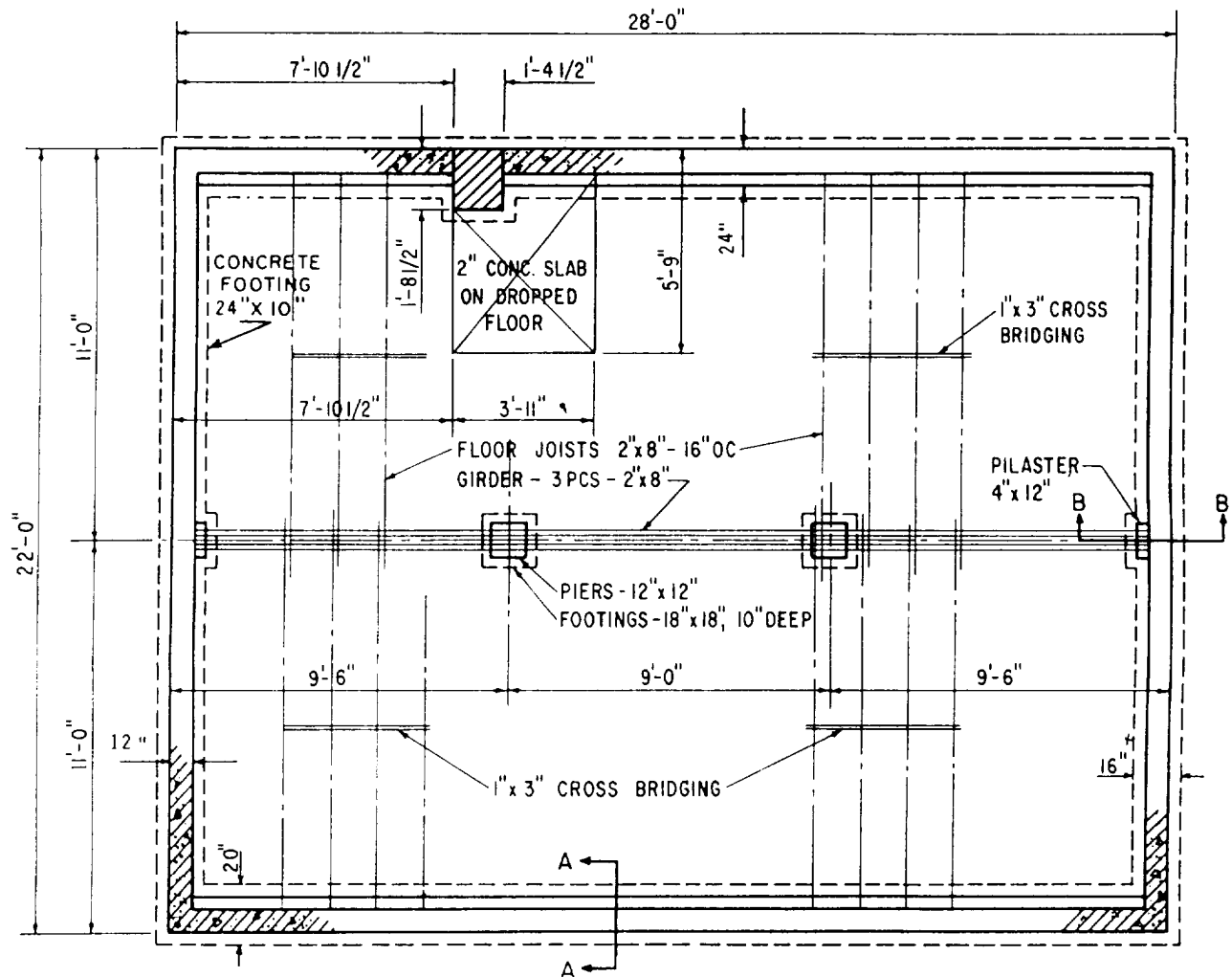
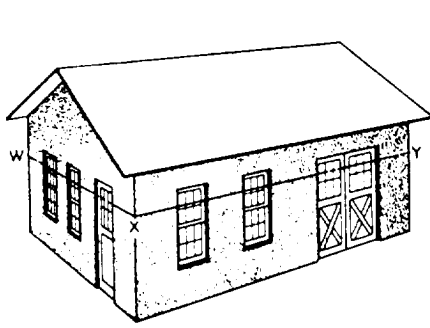
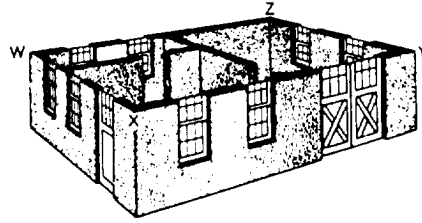

Figure 2-10.—Foundation plan.



PERSPECTIVE VIEW OF A TYPICAL T. O. BUILDING SHOWING CUTTING PLANE WXY



PREVIOUS PERSPECTIVE VIEW AT CUTTING PLANE WXYZ, TOP REMOVED

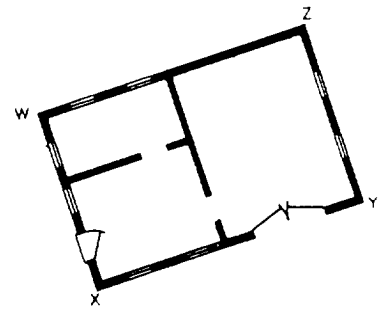

DEVELOPED FLOOR PLAN WXYZ

Figure 2-11.—Floor plan development.

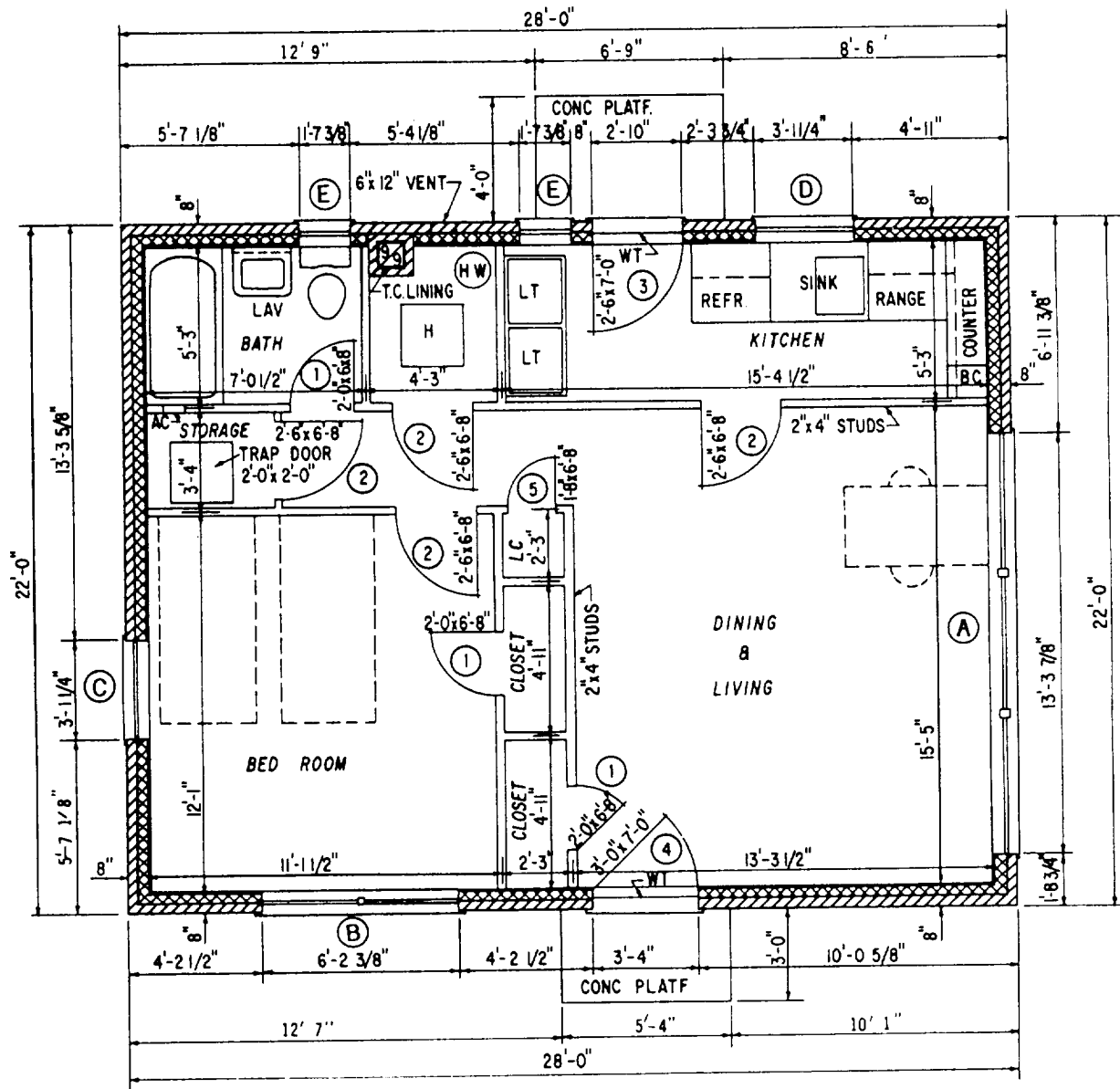

Figure 2-12.—Floor plan.

partitions at the particular floor level. It also shows the number, dimensions, and arrangement of the rooms, the widths and locations of doors and windows, and the locations and character of bathroom, kitchen, and other utility features. You should carefully study figure 2-12. In dimensioning floor plans, it is very important to check the overall dimension against the sum of the partial dimensions of each part of the structure.

### Elevations

The front, rear, and sides of a structure, as they would appear projected on vertical planes, are shown in elevations. Studying the elevation drawing gives you a working idea of the appearance and layout of the structure.

Elevations for a small building are shown in figure 2-13. Note that the wall surfaces of this house will consist of brick and the roof covering of composition shingles. The top of the rafter plate will be 8 feet 2 1/4 inches above the level of the finished first floor, and the tops of the finished door and window openings 7 feet 1 3/4 inches above the same level. The roof will be a gable roof with 4 inches of

rise for every 12 inches length. Each window shown in the elevations is identified by a capital letter that goes with the window schedule (which we'll discuss later in this chapter).

### Framing Plans

Framing plans show the size, number, and location of the structural members (steel or wood) that make up the building framework. Separate framing plans may be drawn for the floors, walls, and roof. The floor framing plan must specify the sizes and spacing of joists, girders, and columns used to support the floor. When detail drawings are needed, the methods of anchoring joists and girders to the columns and foundation walls or footings must be shown. Wall framing plans show the location and method of framing openings and ceiling heights so that studs and posts can be cut. Roof framing plans show the construction of the rafters used to span the building and support the roof. Size, spacing, roof slope, and all details are shown.

**FLOOR PLANS.**— Framing plans for floors are basically plane views of the girders and joists. Figure 2-14 is an example of a typical floor framing plan.

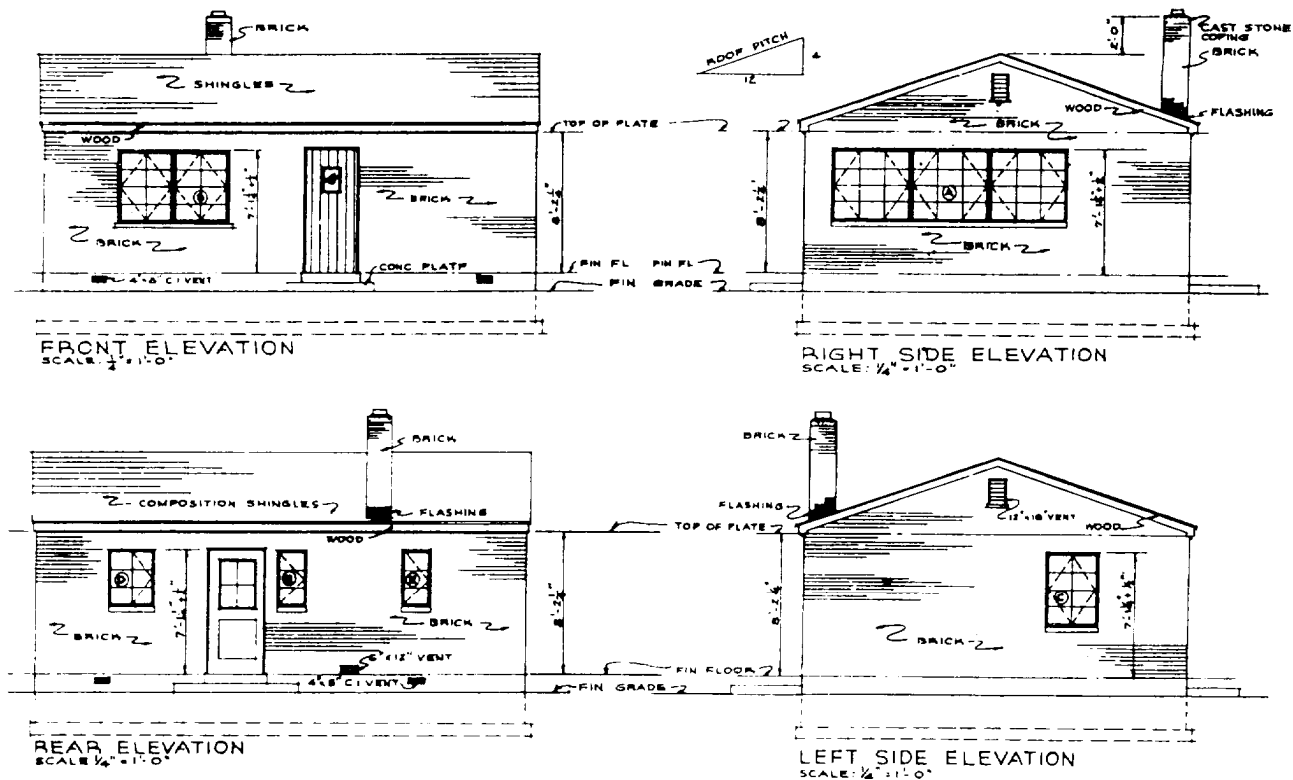

Figure 2-13.—Elevations.



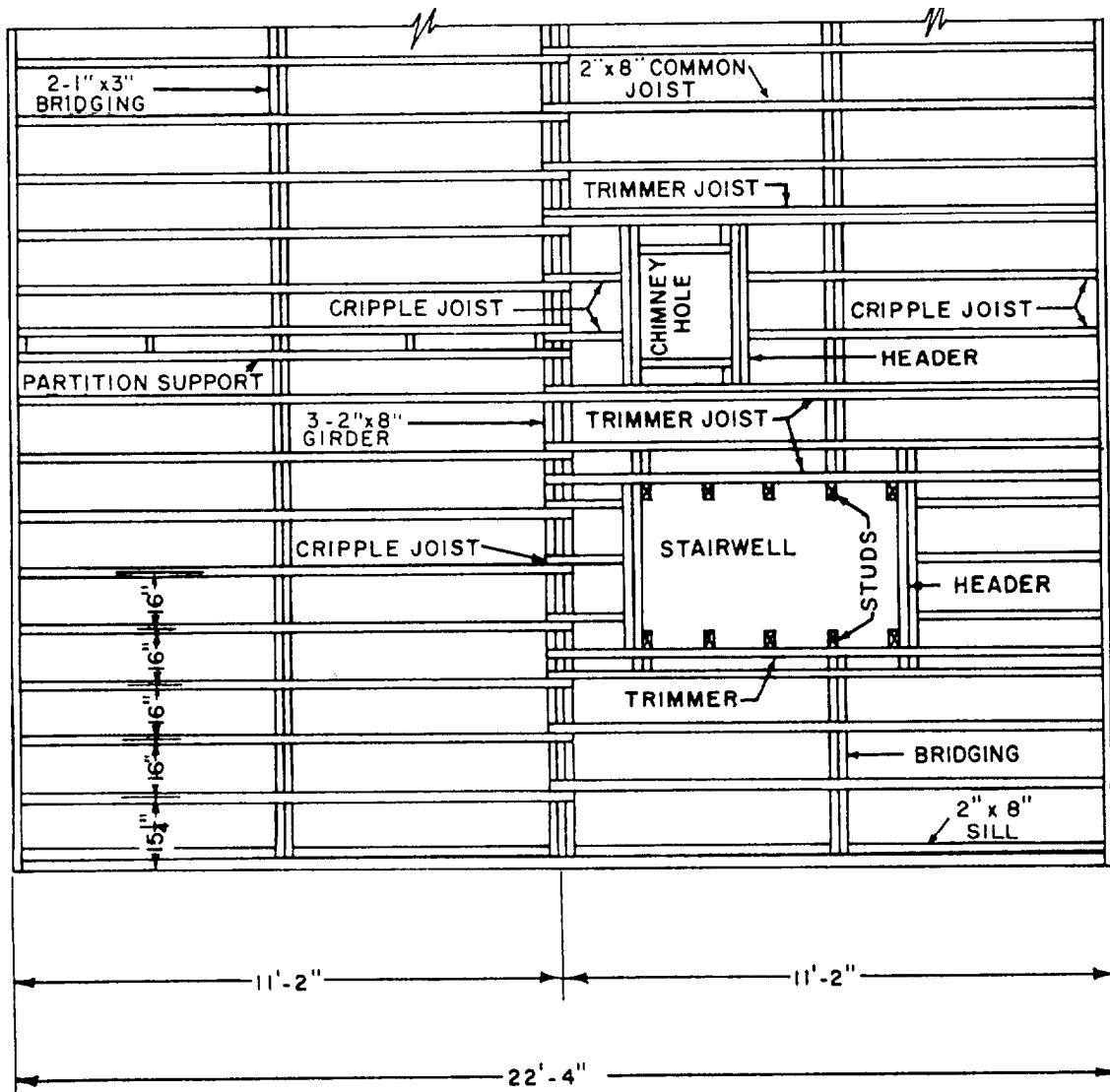

Figure 2-14.—Floor framing plan.

The unbroken, double-line symbol is used to indicate joists, which are drawn in the positions they will occupy in the completed building. Double framing around openings and beneath bathroom fixtures is shown where used. Bridging is shown by a double-line symbol that runs perpendicular to the joists. The number of rows of cross bridging is controlled by the span of the joists; they should not be placed more than 7 or 8 feet apart. A 14-foot span needs only one row of bridging, but a 16-foot span needs two rows.

Notes are used to identify floor openings, bridging, and girts or plates. Nominal sizes are used in specifying lumber. Dimensions need not be given between joists. Such information is given along with notes. For example, 1" x 6" joists @ 2'-0" cc indicates that the joists are to be spaced at intervals of

2 feet 0 inches from center to center. Lengths might not be indicated in framing plans. If you find this to be the case, the overall building dimensions and the dimensions for each bay or distances between columns or posts provide such information.

**ROOF PLANS.**— Framing plans for roofs are drawn in the same manner as floor framing plans. A Builder should visualize the plan as looking down on the roof before any of the roofing material (sheathing) has been added. Rafters are shown in the same manner as joists.

### SHOP DRAWINGS

Shop drawings are sketches, schedules, diagrams, and other information prepared by the contractor

(Builder) to illustrate some portion of the work. As a Builder, you will have to make shop drawings for minor shop and field projects. These may include shop items—such as doors, cabinets, and small portable buildings, prefabricated berthing quarters, and modifications of existing structures.

Shop drawings are prepared from portions of design drawings, or from freehand sketches based on the Builder's past building experience. They must include enough information for the crew to complete the job. Normally, the Builder bases the amount of required detailing on the experience level of the crew expected to complete the project. When an experienced building crew will be doing the work, it is not necessary to show all the fine standard details.

When you make actual drawings, templates (when available) should be used for standard symbols. Standard technical drawing techniques are recommended but not mandatory. For techniques in the skill of drawing, refer to *Blueprint Reading and Sketching*, NAVEDTRA 10077.

### FREEHAND SKETCHES

Builders must be able to read and work from drawings and specifications and make quick, accurate sketches when conveying technical information or ideas. Sketches that you will prepare may be for your own use or for use by other crewmembers. One of the main advantages of sketching is that few materials are required. Basically, pencil and paper are all you need. The type of sketch prepared and personal preference determine the materials used.

Most of your sketches will be done on some type of scratch paper. The advantage of sketching on tracing paper is the ease with which sketches can be

modified or-redeveloped simply by placing transparent paper over previous sketches or existing drawings. Cross-sectional or graph paper may be used to save time when you need to draw sketches to scale. For making dimensional sketches in the field, you will need a measuring tape or pocket rule, depending on the extent of the measurements taken. In freehand pencil sketching, draw each line with a series of short strokes instead of with one stroke. Strive for a free and easy movement of your wrist and fingers. You don't need to be a draftsman or an artist to prepare good working sketches.

Freehand sketches are prepared by the crew leader responsible for the job. Any information that will make the project more understandable may be included, although sketches needn't be prepared in great detail.

### SECTIONAL VIEWS

*LEARNING OBJECTIVE: Upon completing this section, you should be able to interpret sectional views.*

Sectional views, or sections, provide important information about the height, materials, fastening and support systems, and concealed features of a structure. Figure 2-15 shows the initial development of a section and how a structure looks when cut vertically by a cutting plane. The cutting plane is not necessarily continuous, but, as with the horizontal cutting plane in building plans, may be staggered to include as much construction information as possible. Like elevations, sectional views are vertical projections. They are also detail drawings drawn to large scale. This aids in reading, and provides

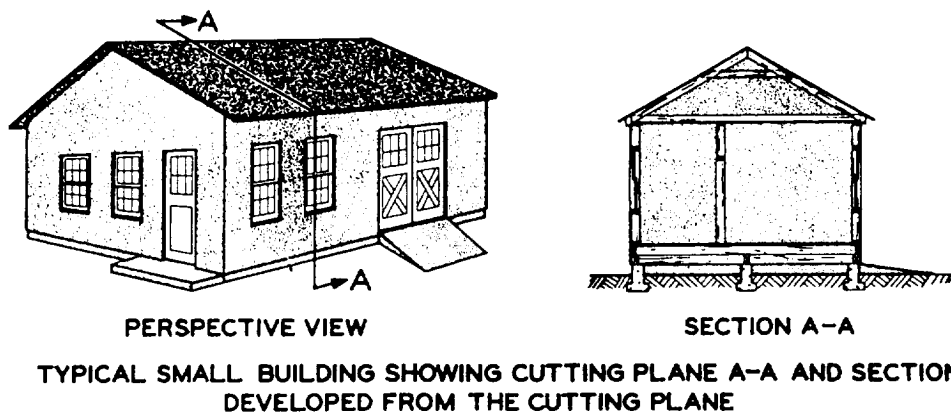

Figure 2-15.—Development of a sectional view.

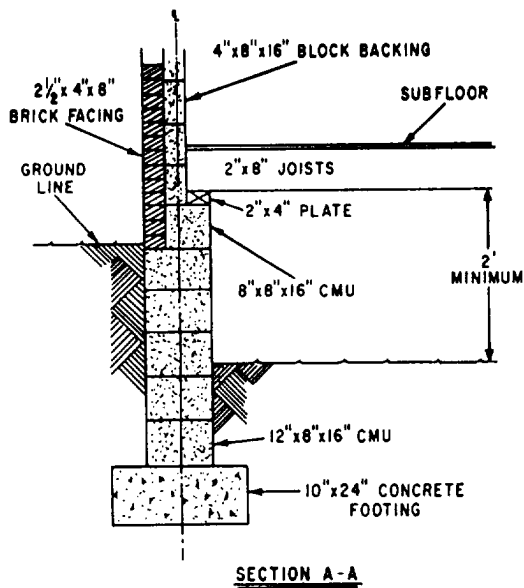

Figure 2-16.—A typical section of a masonry building.

information that cannot be given on elevation or plan views. Sections are classified as typical and specific.

**Typical** sections represent the average condition throughout a structure and are used when construction features are repeated many times. Figure 2-16 shows typical wall section A-A of the foundation plan in

figure 2-10. You can see that it gives a great deal of information necessary for those constructing the building. Let's look at these a little more closely.

The foundation plan shown in figure 2-10 specifies that the main foundation of this structure will consist of a 22- by 28-foot concrete block rectangle. Figure 2-16, which is section A-A of the foundation plan, shows that the front and rear portions of the foundation (28-foot measurements) are made of 12-by-8-by-16-inch CMUs centered on a 10-by-24-inch concrete footing to an unspecified height. These are followed by 8-inch CMUs, which form a 4-inch ledger for floor joist support on top of the 12-inch units. In this arrangement, the 8-inch CMUs serve to form a 4-inch support for the brick. The main wall is then laid with standard 2 1/2-by-4-by-8-inch face brick backed by 4-by-8-by-16-inch CMUs.

Section B-B (figure 2-17) of the foundation plan shows that both side walls (22-foot measurements) are 8 inches thick centered on a 24-inch concrete footing to an unspecified height. It also illustrates the pilaster, a **specific** section of the wall to be constructed for support of the girder. It shows that the pilaster is constructed of 12-by-8-by-16-inch CMUs alternated with 4-by-8-by-16-inch and 8-by-8-by-16-inch CMUs. The hidden lines (dashed

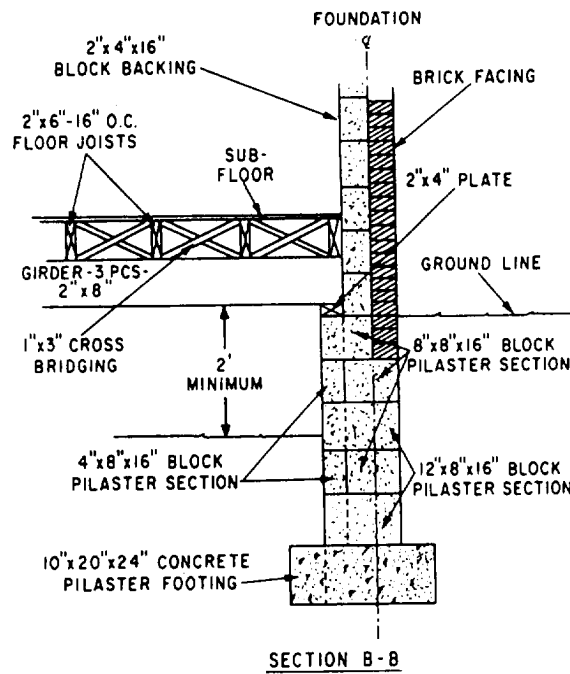
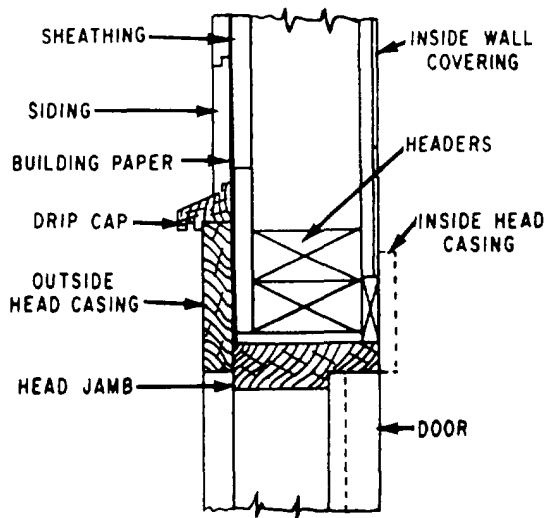

Figure 2-17.—A specific section of a concrete masonry wall.

lines) on the 12-inch-wide units indicate that the thickness of the wall beyond the pilaster is 8 inches. Note how the extra 4-inch thickness of the pilaster provides a center support for the girder, which, in turn, will support the floor joists.

**Details** are large-scale drawings that show the builders of a structure how its various parts are to be connected and placed. Although details do not use the cutting plane indication, they are closely related to sections. The construction of doors, windows, and eaves is customarily shown in detail drawings of buildings. Typical door and window details are shown in figure 2-18. Detail drawings are used whenever the information provided in elevations, plans, and sections is not clear enough for the constructors on the job. These drawings are usually grouped so that references may be made easily from the general drawing.



SECTION THROUGH HEAD JAMB

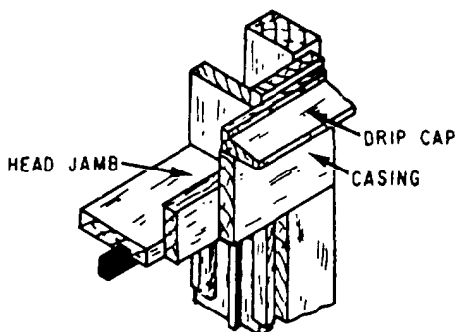

UPPER AND LOWER CORNER DETAILS WINDOW FRAME

Figure 2-18.—Door and window details.

## SCHEDULES

*LEARNING OBJECTIVE: Upon completing this section, you should be able to interpret building schedules.*

A schedule is a group of general notes, usually grouped in a tabular form according to materials of construction. General notes refer to all notes on the drawing not accompanied by a leader and an arrowhead. Item schedules for doors, rooms, footings, and so on, are more detailed. Typical door and window finish schedule formats are presented in the next section.

### DOOR SCHEDULE

Doors may be identified as to size, type, and style with code numbers placed next to each symbol in a plan view. This code number, or mark, is then entered on a line in a door schedule, and the principal characteristics of the door are entered in successive columns along the line. The "Amount Required" column allows a quantity check on doors of the same design as well as the total number of doors required. By using a number with a letter, you will find that the mark serves a double purpose: the number identifies the floor on which the door is located, and the letter identifies the door design. The "Remarks" column allows identification by type (panel or flush), style, and material. The schedule is a convenient way of presenting pertinent data without making the Builder refer to the specification. A typical door schedule is shown in table 2-1.

### WINDOW SCHEDULE

A window schedule is similar to a door schedule in that it provides an organized presentation of the significant window characteristics. The mark used in the schedule is placed next to the window symbol that applies on the plan view of the elevation view (figure 2-13). A similar window schedule is shown in table 2-2.

### FINISH SCHEDULE

A finish schedule specifies the interior finish material for each room and floor in the building. The finish schedule provides information for the walls, floors, ceilings, baseboards, doors, and window trim. An example of a finish schedule is shown in table 2-3.

Table 2-1.—Door Schedule

MARK	SIZE	AMOUNT REQUIRED	REMARKS
1	2'0" × 6'8" × 1 3/8"	3	Flush door
2	2'6" × 6'8" × 1 3/8"	4	Flush door
3	2'6" × 6'8" × 1 3/8"	1	Ext flush door, 1 light
4	3'0" × 7'0" × 1 3/4"	1	Ext flush door, 4 lights
5	1'8" × 6'8" × 1 3/8"	1	Flush door

Table 2-2.—Window Schedule

MARK	SIZE	AMOUNT REQUIRED	REMARKS
A	4'5 1/8" × 4'2 5/8"	3	Metal frame
B	3'1 1/8" × 4'2 5/8"	2	Metal frame
C	3'1" × 4'2 5/8"	1	Metal frame
D	3'1" × 4'2 5/8"	1	Metal frame
E	1'7 5/8" × 4'2 5/8"	2	Metal frame

Table 2-3.—Finish Schedule

ROOM	FLOOR	WALLS	CEILING	BASEBOARD	TRIM
Dining and living	1" × 3" oak	1/2" Drywall paint white	1/2" Drywall paint white	Wood	Wood
Bedroom	1" × 3" oak	1/2" Drywall paint white	1/2" Drywall paint white	Wood	Wood
Bathroom	Linoleum-tan	1/2" Drywall paint white	1/2" Drywall paint white	Lino-cove	Wood
Kitchen	Linoleum-tan	1/2" Drywall paint white	1/2" Drywall paint white	Lino-cove	Wood
Utility room	Linoleum-tan	1/2" Drywall paint white	1/2" Drywall paint white	Lino-cove	Wood
Hall	1" × 3" oak	1/2" Drywall paint white	1/2" Drywall paint white	Wood	Wood

## NOTES ON SCHEDULES

Notes are generally placed a minimum of 3 inches below the “Revision” block in the right-hand side of the first sheet. The purpose of these notes is to give additional information that clarifies a detail or explains how a certain phase of construction is to be performed. You should read all notes, along with the specifications, while you are planning a project.

### WRITTEN SPECIFICATIONS

*LEARNING OBJECTIVE: Upon completing this section, you should be able to interpret written construction specifications.*

Because many aspects of construction cannot be shown graphically, even the best prepared construction drawings often inadequately show some portions of a project. For example, how can anyone show on a drawing the quality of workmanship required for the installation of doors and windows? Or, who is responsible for supplying the materials? These are things that can be conveyed only by hand-lettered notes. The standard procedure is to supplement construction drawings with detailed written instructions. These written instructions, called specifications (or more commonly specs), define and limit materials and fabrication to the intent of the engineer or designer.

Usually, it is the responsibility of the design engineer to prepare project specifications. As a Builder, you will be required to read, interpret, and use these in your work as a crew leader or supervisor. You must be familiar with the various types of federal, military, and nongovernmental reference specifications used in preparing project specs. When assisting the engineer in preparing or using specifications, you also need to be familiar with the general format and terminology used.

### NAVFAC SPECIFICATIONS

NAVFAC specifications are prepared by the Naval Facilities Engineering Command (NAVFAC-ENGCOCM), which sets standards for all construction work performed under its jurisdiction. This includes

work performed by the Seabees. There are three types of NAVFAC specifications.

### NAVFACENGCOCM Guide Specifications

NAVFACENGCOCM guide specifications (NFGS) are the primary basis for preparing specifications for construction projects. These specifications define and establish minimum criteria for construction, materials, and workmanship and must be used as guidance in the preparation of project specifications. Each of these guide specifications (of which there are more than 300) has been written to encompass a wide variety of different materials, construction methods, and circumstances. They must also be tailored to suit the work actually required by the specific project.

To better explain this, let's look at figure 2-19, which is a page taken from a NAVFACENGCOCM guide specification. In this figure, you can see that there are two paragraphs numbered 3.2.1. This indicates that the spec writer must choose the paragraph that best suits the particular project for which he is writing the specification. The capital letters *I* and *J* in the right-hand margin next to those paragraphs refer to footnotes (contained elsewhere in the same guide specification) that the spec writer must follow when selecting the best paragraph. Additionally, you can see that some of the information in figure 2-19 is enclosed in brackets ([ ]). This indicates other choices that the spec writer must make. Guide specifications should be modified and edited to reflect the latest proven technology, materials, and methods.

### EFD Regional Guide Specifications

Engineering Field Division regional guide specifications are used in the same way as the NAVFACENGCOCM guide specifications but only in areas under the jurisdiction of an EFD of the Naval Facilities Engineering Field Command. When the spec writer is given a choice between using an EFD regional guide specification or a NAVFACENGCOCM guide specification with the same identification number, the writer must use the one that has the most recent date. This is because there can only be one valid guide specification for a particular area at any one time.

## PART 3 - EXECUTION

**3.1 SURFACES AND CONDITIONS:** Do not apply shingle roofing on surfaces that are unsuitable or that prevent a satisfactory application. Ensure that roof is smooth, clean, dry, and without loose knots. Cover knotholes and cracks with sheet metal nailed securely to the sheathing. Properly flash and secure vents and other roof projections and drive projecting nails firmly home.

**3.2 APPLICATION:** The manufacturer's written instructions shall be followed for applications not listed in this specification and in cases of conflict with this specification.

**3.2.1 Underlayment (for Roof Slopes 4 Inches Per Foot and Greater):** (I)  
Apply underlayment consisting of one layer of No. 15 asphalt-saturated felt to the roof deck. Lay felt parallel to roof eaves continuing from eaves to ridge, using 2-inch head laps, 6-inch laps from both sides over all hips and ridges, and 4-inch end laps in the field of the roof. Nail felt sufficiently to hold until shingles are applied. Turn underlayment up vertical surfaces not less than 4 inches.

**\*\*OR\*\***

**3.2.1 Underlayment (for Roof Slopes (Between 2 Inches and 4 Inches Per Foot) (4 Inches Per Foot and Greater)):** (I) (J)  
Apply underlayment consisting of two layers of No. 15 asphalt-saturated felt to the roof deck. Provide a 19-inch wide strip of felt as a starter sheet to maintain the specified number of layers throughout the roof. Lay felt parallel to roof eaves continuing from eaves to ridge, using 19-inch head laps for 6-inch laps from both sides over all hips and ridges, and 12-inch end laps in the field of the roof. Nail felt sufficiently to hold until shingles are applied. Confine nailing to the upper 17 inches of each felt. Turn underlayment up vertical surfaces not less than 4 inches.

**3.2.2 Metal Drip Edges:** Provide metal drip edges as specified in Section 07600, "Flashing and Sheet Metal," applied directly on the wood deck at the eaves and over the underlayment at the rakes. Extend back from the edge of the deck not more than 3 inches and secure with fasteners spaced not more than 10 inches on center along the inner edge.

**(3.2.3 Eaves Flashing (for Roof Slopes 4 Inches Per Foot and Greater):** (K)  
Provide eaves flashing strips consisting of 55-pound or heavier smooth-surface roll roofing. The flashing strips shall overhang the metal drip edge 1/4 to 3/8 inch and extend up the slope far enough to cover a point 12 inches inside the interior face of the exterior wall. Where overhangs require flashings wider than 36 inches, locate the laps outside the exterior wall face. The laps shall be at least 2 inches wide and cemented. End laps shall be 12 inches and cemented.)

Figure 2-19.—Sample page from a NAVFACENGCOM guide specification.

## Standard Specifications

Standard specifications are written for a small group of specialized structures that must have uniform construction to meet rigid operational requirements. NAVFAC standard specifications

contain references to federal, military, other command and bureau, and association specifications. NAVFAC standard specifications are referenced or copied in project specifications, and can be modified with the modification noted and referenced. An example of a standard specification with modification is shown below:

“The magazine shall be Arch, Type I, conforming to specifications S-M8E, except that all concrete shall be class F-1.”

## OTHER SPECIFICATIONS

The following specifications establish requirements mainly in terms of performance. Referencing these documents in project specifications assures the procurement of economical facility components and services while considerably reducing the number of words required to state such requirements.

### Federal and Military Specifications

Federal specifications cover the characteristics of materials and supplies used jointly by the Navy and other government agencies. These specifications do not cover installation or workmanship for a particular project, but specify the technical requirements and tests for materials, products, or services. The engineering technical library should have all the commonly used federal specifications pertinent to Seabee construction.

Military specifications are those specifications that have been developed by the Department of Defense. Like federal specifications, they also cover the characteristics of materials. They are identified by DOD or MIL preceding the first letter and serial number.

### Technical Society and Trade Association Specifications

Technical society specifications should be referenced in project specifications when applicable. The organizations publishing these specifications include, but are not limited to, the American National Standards Institute (ANSI), the American Society for Testing and Materials (ASTM), the Underwriters Laboratories (UL), and the American Iron and Steel Institute (AISI). Trade association specifications contain requirements common to many companies within a given industry.

### Manufacturer's Specifications

Manufacturer's specifications contain the precise description for the manner and process for making, constructing, compounding, and using any items the

manufacturer produces. They should not be referenced or copied verbatim in project specifications but may be used to aid in preparing project specifications.

## PROJECT SPECIFICATIONS

Construction drawings are supplemented by written project specifications. Project specifications give detailed information regarding materials and methods of work for a particular construction project. They cover various factors relating to the project, such as general conditions, scope of work, quality of materials, standards of workmanship, and protection of finished work.

The drawings, together with the project specifications, define the project in detail and show exactly how it is to be constructed. Usually, drawings for an important project are accompanied by a set of project specifications. The drawings and project specifications are inseparable. Drawings indicate what the project specifications do not cover. Project specifications indicate what the drawings do not portray, or they further clarify details that are not covered amply by the drawings and notes on the drawings. When you are preparing project specifications, it is important that the specifications and drawings be closely coordinated so that discrepancies and ambiguities are minimized. Whenever there is conflicting information between the drawings and project specs, the specifications take precedence over the drawings.

## ORGANIZATION OF SPECIFICATIONS

For consistency, the Construction Standards Institute (CSI) has organized the format of specifications into 16 basic divisions. These divisions, used throughout the military and civilian construction industry, are listed in order as follows:

1. **General Requirements** include information that is of a general nature to the project, such as inspection requirements and environmental protection.
2. **Site Work** includes work performed on the site, such as grading, excavation, compaction, drainage, site utilities, and paving.
3. **Concrete** includes precast and cast-in-place concrete, formwork, and concrete reinforcing.



4. **Masonry** includes concrete masonry units, brick, stone, and mortar.
5. **Metals** include such items as structural steel, open-web steel joists, metal stud and joist systems, ornamental metal work, grills, and louvers. (Sheet-metal work is usually included in Division 7.)
6. **Wood and Plastics** include wood and wood framing, rough and finish carpentry, foamed plastics, fiberglass-reinforced plastics, and laminated plastics.
7. **Thermal and Moisture Protection** includes such items as waterproofing, dampproofing, insulation, roofing materials, sheet metal and flashing, caulking, and sealants.
8. **Doors and Windows** include doors, windows, finish hardware, glass and glazing, storefront systems, and similar items.
9. **Finishes** include such items as floor and wall coverings, painting, lathe, plaster, and tile.
10. **Specialties** include prefabricated products and devices, such as chalkboards, moveable partitions, fire-fighting devices, flagpoles, signs, and toilet accessories.
11. **Equipment** includes such items as medical equipment, laboratory equipment, food service equipment, kitchen and bath cabinetwork, and counter tops.
12. **Furnishings** include prefabricated cabinets, blinds, drapery, carpeting, furniture, and seating.
13. **Special Construction** includes such items as prefabricated structures, integrated ceiling systems, and swimming pools.
14. **Conveying Systems** include dumbwaiters, elevators, moving stairs, material-handling systems, and other similar conveying systems.
15. **Mechanical Systems** include plumbing, heating, air conditioning, fire-protection systems, and refrigeration systems.
16. **Electrical Systems** include electrical service and distribution systems, electrical power equipment, electric heating and cooling systems, lighting, and other electrical items.

Each of the above divisions is further divided into sections. You can find a discussion of the required

sections of Division 1 in *Policy and Procedures for Project Drawing and Specification Preparation*, MIL-HDBK-1006/1. The Division 1 sections, sometimes referred to as “boilerplate,” are generally common to all projects accomplished under a construction contract. Divisions 2 through 16 contain the technical sections that pertain to the specific project for which the spec writer has prepared the specification. These technical sections follow the CSI-recommended three-part section format. The first part, General, includes requirements of a general nature. Part 2, Products, addresses the products or quality of materials and equipment to be included in the work. The third part, Execution, provides detailed requirements for performance of the work.

## GUIDANCE

Usually, the engineer or spec writer prepares each section of a specification based on the appropriate guide specification listed in the *Engineering and Design Criteria for Navy Facilities*, MIL-BUL-34. This military bulletin (issued quarterly by the Naval Construction Battalion Center, Port Hueneme, California) lists current NAVFACENGCOM guide specifications, standard specifications and drawings, definitive drawings, NAVFAC design manuals, and military handbooks that are used as design criteria.

As discussed earlier, when writing the specifications for a project, you must modify the guide specification you are using to fit the project. Portions of guide specifications that concern work not included in the project should be deleted. When portions of the required work are not included in a guide specification, then you must prepare a suitable section to cover the work, using language and form similar to the guide specification. Do not combine work covered by various guide specifications into one section unless the work is minor in nature. Do not reference the guide specification in the project specifications. You must use the guide spec only as a manuscript that can be edited and incorporated into the project specs.

The preceding discussion provides only a brief overview of construction specifications. For additional guidance regarding specification preparation, you should refer to *Policy and Procedures for Project Drawing and Specification Preparation*, MIL-HDBK- 1006/1.

## RECOMMENDED READING LIST

You therefore need to ensure that you are **studying the latest revision.**

### NOTE

Although the following reference was current when this TRAMAN was published, its continued currency cannot be assured.

*Engineering Aid 3 & 2*, Vol. 3, NAVEDTRA 10629-1, Naval Education and Training Program Management Support Activity, Pensacola, Fla., 1987.

## CHAPTER 3

# WOODWORKING TOOLS, MATERIALS, AND METHODS

As a Builder, hand and power woodworking tools are essential parts of your trade. To be a proficient woodworking craftsman, you must be able to use and maintain a large variety of field and shop tools effectively. To perform your work quickly, accurately, and safely, you must select and use the correct tool for the job at hand. Without the proper tools and the knowledge to use them, you waste time, reduce efficiency, and may injure yourself or others.

Power tools not only are essential in performing specific jobs, but also play an important role in your daily work activities. Keep in mind that you are responsible for knowing and observing all safety precautions applicable to the tools and equipment you operate. For additional information on the topics discussed in this chapter, you are encouraged to study *Tools and Their Uses*, NAVEDTRA 10085-B2. Because that publication contains a detailed discussion of common tools used by Builders, we will not repeat that information in this chapter.

In this chapter, several of the most common power tools used by Builders are briefly described. Their uses, general characteristics, attachments, and safety and operating features are outlined. To become skilled with these power tools and hand tools, you must use them. You should also study the manufacturer's operator and maintenance guides for each tool you use for additional guidance. We will also be covering materials and methods of woodworking.

### POWER TOOLS

*LEARNING OBJECTIVE: Upon completing this section, you should be able to determine the proper use and maintenance requirements of portable power tools.*

Your duties as a Builder include developing and improving your skills and techniques when working with different power tools. In this section, we'll identify and discuss the most common power tools that are in the Builder's workshop or used on the jobsite. We'll also discuss safety precautions as they

relate to the particular power tool under discussion. You must keep in mind and continually stress to your crew that woodworking power tools can be dangerous, and that safety is everyone's responsibility.

### SHOP TOOLS

As a Builder, you might be assigned to a shop. Therefore, you will need to know some of the common power tools and equipment found there.

#### Shop Radial Arm Saw

Figure 3-1 illustrates a typical shop radial arm saw. The procedures used in the operation, maintenance, and lubrication of any shop radial arm saw are found in the manufacturers' operator and maintenance manuals. The safety precautions to be observed for this saw are found in these same manuals. The primary difference between this saw and other saws of this type (field saws) is the location of controls.

#### Tilt-Arbor Table Bench Saw

A tilt-arbor table bench saw (figure 3-2) is so named because the saw blade can be tilted for cutting bevels by tilting the arbor. The arbor, located beneath the table, is controlled by the tilt handwheel. In earlier types of bench saws, the saw blade remained stationary and the table was tilted. A canted (tilted) saw table is hazardous in many ways; most modern table saws are of the tilt-arbor type.

To rip stock, remove the cutoff gauges and set the rip fence away from the saw by a distance equal to the desired width of the piece to be ripped off. The piece is placed with one edge against the fence and fed through with the fence as a guide.

To cut stock square, set the cutoff gauge at 90° to the line of the saw and set the ripping fence to the outside edge of the table, away from the stock to be cut. The piece is then placed with one edge against

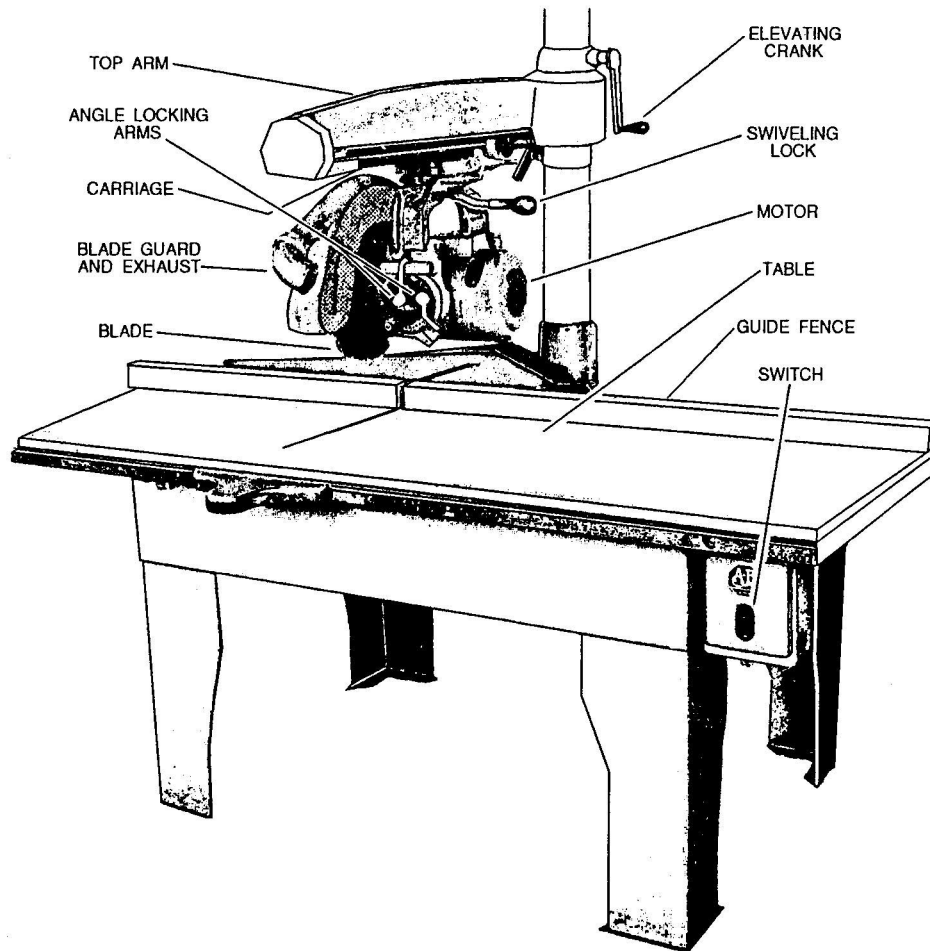

**Figure 3-1.—A shop radial arm saw.**

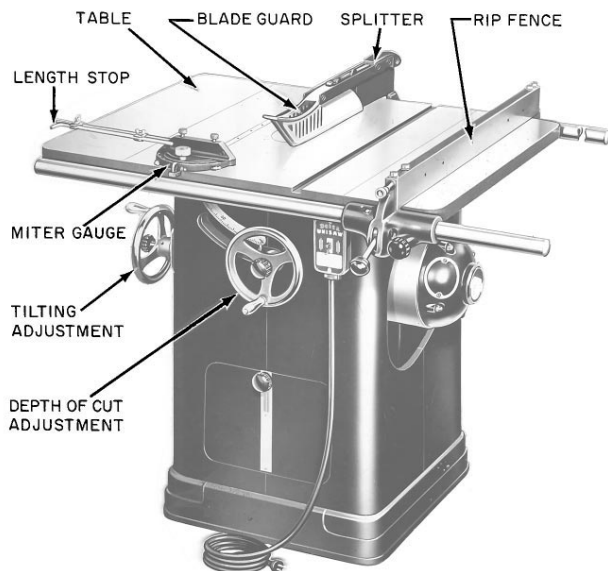

29.136

**Figure 3-2.—Tilt-arbor bench saw.**

the cutoff gauge, held firmly, and fed through by pushing the gauge along its slot.

The procedure for cutting stock at an angle other than 90° (called miter cutting) is similar, except that the cutoff gauge is set to bring the piece to the desired angle with the line of the saw.

For ordinary ripping or cutting, the saw blade should extend above the table top 1/8 to 1/4 inch plus the thickness of the piece to be sawed. The vertical position of the saw is controlled by the depth of cut handwheel, shown in figure 3-2. The angle of the saw blade is controlled by the tilt handwheel. Except when its removal is absolutely unavoidable, the guard must be kept in place.

The slot in the table through which the saw blade extends is called the throat. The throat is contained in a small, removable section of the table called the throat plate. The throat plate is removed when it is necessary to insert a wrench to remove the saw blade.

The blade is held on the arbor by the arbor nut. A saw is usually equipped with several throat plates, containing throats of various widths. A wider throat is required when a dado head is used on the saw. A dado head consists of two outside grooving saws (which are much like combination saws) and as many intermediate chisel-type cutters (called chippers) as are required to make up the designated width of the groove or dado. Grooving saws are usually 1/8-inch thick; consequently, one grooving saw will cut a 1/8-inch groove, and the two, used together, will cut a 1/4-inch groove. Intermediate cutters come in various thicknesses.

Observe the following safety precautions when operating the tilt-arbor table bench saw:

- Do not use a rip saw blade for crosscutting or a crosscut saw blade for ripping. When ripping and crosscutting frequently, you should install a combination blade to eliminate constantly changing the blade. Make sure the saw blade is sharp, unbroken, and free from cracks before using. The blade should be changed if it becomes dull, cracked, chipped, or warped.
- Be sure the saw blade is set at proper height above the table to cut through the wood.
- Avoid the hazard of being hit by materials caused by kickbacks by standing to one side of the saw.
- Always use a push stick to push short, narrow pieces between the saw blade and the gauge.
- Keep stock and scraps from accumulating on the saw table and in the immediate working area.
- Never reach over the saw to obtain material from the other side.
- When cutting, do not feed wood into the saw blade faster than it will cut freely and cleanly.
- Never leave the saw unattended with the power on.

### Band Saw

Although the band saw (figure 3-3) is designed primarily for making curved cuts, it can also be used for straight cutting. Unlike the circular saw, the band saw is frequently used for freehand cutting.

The band saw has two large wheels on which a continuous narrow saw blade, or band, turns, just as a belt is turned on pulleys. The lower wheel, located below the working table, is connected to the motor directly or by means of pulleys or gears and serves as the driver pulley. The upper wheel is the driven pulley.

The saw blade is guided and kept in line by two sets of blade guides, one fixed set below the table and one set above with a vertical sliding adjustment. The alignment of the blade is adjusted by a mechanism on the backside of the upper wheel. Tensioning of the blade—tightening and loosening—is provided by another adjustment located just back of the upper wheel.

Cutoff gauges and ripping fences are sometimes provided for use with band saws, but you'll do most of your work freehand with the table clear. With this type of saw, it is difficult to make accurate cuts when gauges or fences are used.

The size of a band saw is designated by the diameter of the wheels. Common sizes are 14-, 16-, 18-, 20-, 30-, 36-, 42-, and 48-inch-diameter wheel machines. The 14-inch size is the smallest practical band saw. With the exception of capacity, all band

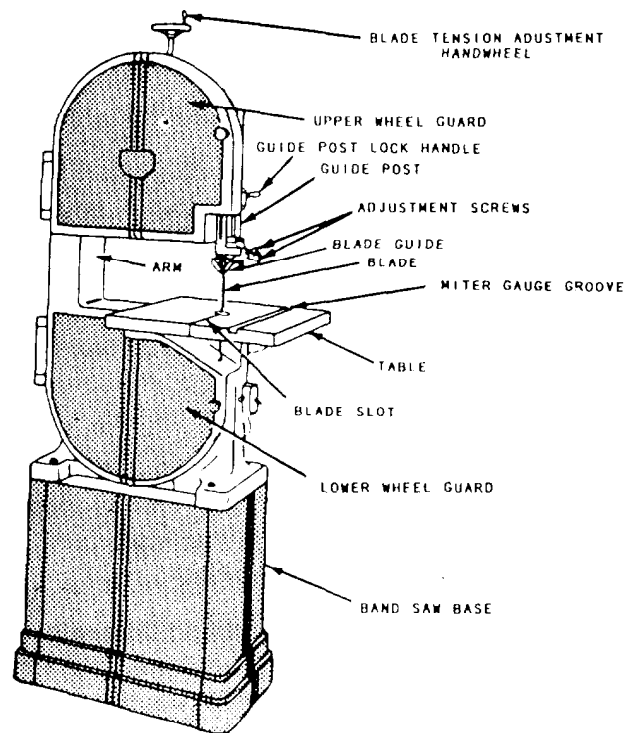

Figure 3-3.—Band saw.

saws are much the same with regard to maintenance, operation, and adjustment.

A rule of thumb used by many Seabees is that the width of the blade should be one-eighth the minimum radius to be cut. Therefore, if the piece on hand has a 4-inch radius, the operator should select a 1/2-inch blade. Don't construe this to mean that the minimum radius that can be cut is eight times the width of the blade; rather, the ratio indicates the practical limit for high-speed band saw work.

Blades, or bands, for band saws are designated by points (tooth points per inch), thickness (gauge), and width. The required length of a blade is found by adding the circumference of one wheel to twice the distance between the wheel centers. Length can vary within a limit of twice the tension adjustment range.

Band saw teeth are shaped like the teeth in a hand rip saw blade, which means that their fronts are filed at 90° to the line of the saw. Reconditioning procedures are the same as those for a hand rip saw, except that very narrow band saws with very small teeth must usually be set and sharpened by special machines.

Observe the following safety precautions when operating a band saw:

- Keep your fingers away from the moving blade.
- Keep the table clear of stock and scraps so your work will not catch as you push it along.
- Keep the upper guide just above the work, not excessively high.
- Don't use cracked blades. If a blade develops a click as it passes through the work, the operator should shut off the power because the click is a danger signal that the blade is cracked and may be ready to break. After the saw blade has stopped moving, it should be replaced with one in proper condition.
- If the saw blade breaks, the operator should shut off the power immediately and not attempt to remove any part of the saw blade until the machine is completely stopped.
- If the work binds or pinches on the blade, the operator should never attempt to back the work away from the blade while the saw is in motion since this may break the blade. The operator should always see that the blade is working freely through the cut.

A band saw should not be operated in a location where the temperature is below 45°F. The blade may break from the coldness.

- Using a small saw blade for large work or forcing a wide saw on a small radius is bad practice. The saw blade should, in all cases, be as wide as the nature of the work will permit.
- Band saws should not be stopped by thrusting a piece of wood against the cutting edge or side of the band saw blade immediately after the power has been shut off; doing so may cause the blade to break. Band saws with 36-inch-wheel diameters and larger should have a hand or foot brake.
- Particular care should be taken when sharpening or brazing a band saw blade to ensure the blade is not overheated and the brazed joints are thoroughly united and finished to the same thickness as the rest of the blade. It is recommended that all band saw blades be butt welded where possible; this method is much superior to the old style of brazing.

### Drill Press

Figure 3-4 shows a drill press. (The numbers in the figure correspond to those in the following text.) The drill press is an electrically operated power machine that was originally designed as a metal-working tool; as such, its use would be limited in the average woodworking shop. However, accessories, such as a router bit or shaper heads, jigs, and special techniques, now make it a versatile woodworking tool as well.

The motor (10) is mounted to a bracket at the rear of the head assembly (1) and designed to permit V-belt changing for desired spindle speed without removing the motor from its mounting bracket. Four spindle speeds are obtained by locating the V-belt on any one of the four steps of the spindle-driven and motor-driven pulleys. The belt tensioning rod (16) keeps proper tension on the belt so it doesn't slip.

The controls of all drill presses are similar. The terms "right" and "left" are relative to the operator's position standing in front of and facing the drill press. "Forward" applies to movement toward the operator. "Rearward" applies to movement away from the operator.

The on/off switch (11) is located in the front of the drill press for easy access.

The spindle and quill feed handles (2) radiate from the spindle and quill pinion feed (3) hub, which is located on the lower right-front side of the head assembly (1). Pulling forward and down on any one of the three spindle and quill feed handles, which point upward at the time, moves the spindle and quill assembly downward. Release the feed handle (2) and the spindle and quill assembly return to the retracted or upper position by spring action.

The quill lock handle (4) is located at the lower left-front side of the head assembly. Turn the quill lock handle clockwise to lock the quill at a desired operating position. Release the quill by turning the quill lock handle counterclockwise. However, in

most cases, the quill lock handle will be in the released position.

The head lock handle (5) is located at the left-rear side of the head assembly. Turn the head leek handle clockwise to lock the head assembly at a desired vertical height on the bench column. Turn the head lock handle counterclockwise to release the head assembly. When operating the drill press, you must ensure that the head lock handle is tight at all times.

The head support collar handle (6) is located at the right side of the head support collar and below the head assembly. The handle locks the head support collar, which secures the head vertically on the bench column, and prevents the head from dropping when the head lock handle is released. Turn the head support collar lock handle clockwise to lock the support to the bench column and counterclockwise to

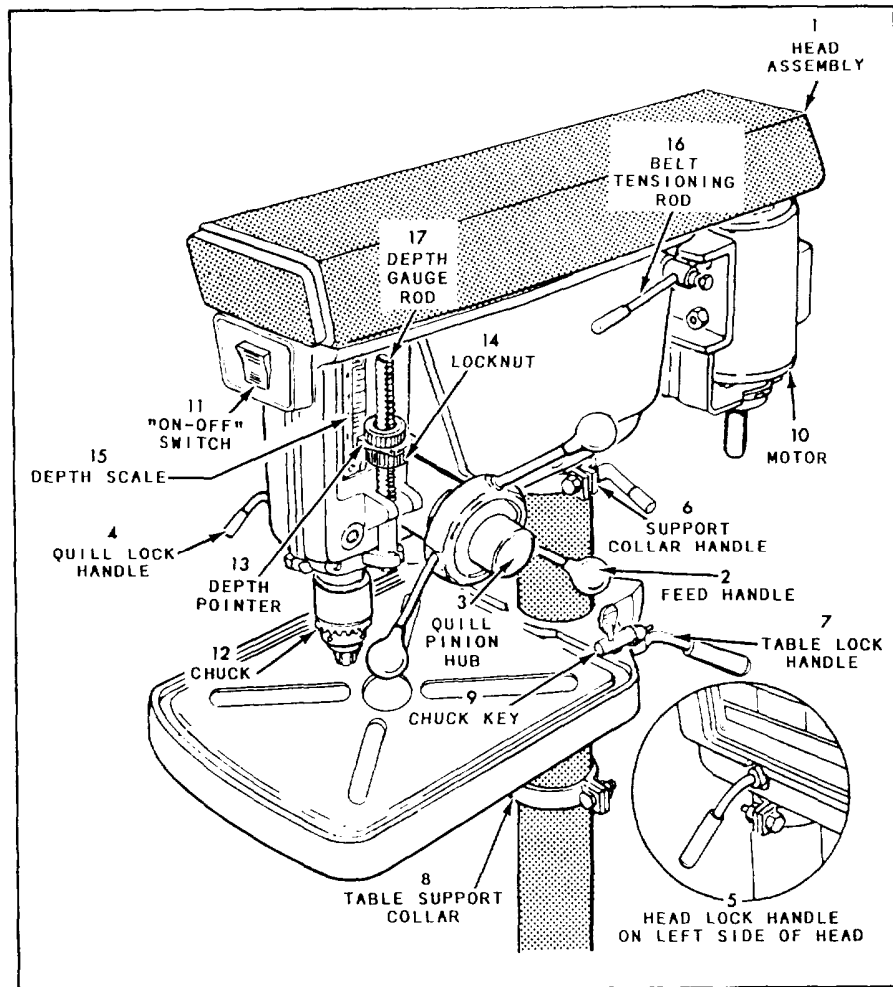

Figure 3-4.—Drill press.

release the support. When operating the drill press, ensure that the head support collar lock handle is tight at all times.

As you face the drill press, the tilting table lock handle is located at the right-rear side of the tilting table bracket. The lockpin secures the table at a horizontal or 45° angle. This allows you to move the table to the side, out of the way for long pieces of wood. The table support collar (8) allows you to raise or lower the table. Turn the tilting table lock handle counterclockwise to release the tilting table bracket so it can be moved up and down or around the bench column. Lock the tilting table assembly at the desired height by turning the lock handle clockwise. When operating the drill press, ensure that the tilting table lock handle is tight at all times.

The adjustable locknut (14) is located on the depth gauge rod (17). The purpose of the adjustable locknut is to regulate depth drilling. Turn the adjustable locknut clockwise to decrease the downward travel of the spindle. The locknut must be secured against the depth pointer (13) when operating the drill press. The depth of the hole is shown on the depth scale (15).

Observe the following safety precautions when operating a drill press:

- Make sure that the drill is properly secured in the chuck (12) and that the chuck key (9) is removed before starting the drill press.
- Make sure your material is properly secured.
- Operate the feed handle with a slow, steady pressure to make sure you don't break the drill bit or cause the V-belt to slip.
- Make sure all locking handles are tight and that the V-belt is not slipping.
- Make sure the electric cord is securely connected and in good shape.
- Make sure you are not wearing hanging or loose clothing.
- Listen for any sounds that may be signs of trouble.
- After you have finished operating the drill press, make sure the area is clean.

## Woodworking Lathe

The woodworking lathe is, without question, the oldest of all woodworking machines. In its early form, it consisted of two holding centers with the suspended stock being rotated by an endless rope belt. It was operated by having one person pull on the rope hand over hand while the cutting was done by a second person holding crude hand lathe tools on an improvised beam rest.

The actual operations of woodturning performed on a modern lathe are still done to a great degree with woodturner's hand tools. However, machine lathe work is coming more and more into use with the introduction of newly designed lathes for that purpose.

The lathe is used in turning or shaping round drums, disks, and any object that requires a true diameter. The size of a lathe is determined by the maximum diameter of the work it can swing over its bed. There are various sizes and types of wood lathes, ranging from very small sizes for delicate work to large surface or bull lathes that can swing jobs 15 feet in diameter.

Figure 3-5 illustrates a type of lathe that you may find in your shop. It is made in three sizes to swing 16-, 20-, and 24-inch diameter stock. The lathe has four major parts: bed, headstock, tailstock, and tool rest.

The lathe shown in figure 3-5 has an iron bed and comes in assorted lengths. The bed is a broad, flat surface that supports the other parts of the machine.

The headstock is mounted on the left end of the lathe bed. All power for the lathe is transmitted through the headstock. It has a fully enclosed motor that gives variable spindle speed. The spindle is threaded at the front end to receive the faceplates. A faceplate attachment to the motor spindle is furnished to hold or mount small jobs having large diameters. There is also a flange on the rear end of the spindle to receive large faceplates, which are held securely by four stud bolts.

The tailstock is located on the right end of the lathe and is movable along the length of the bed. It supports one end of the work while the other end is being turned by the headstock spur. The tail center can be removed from the stock by simply backing the screw. The shank is tapered to center the point automatically.



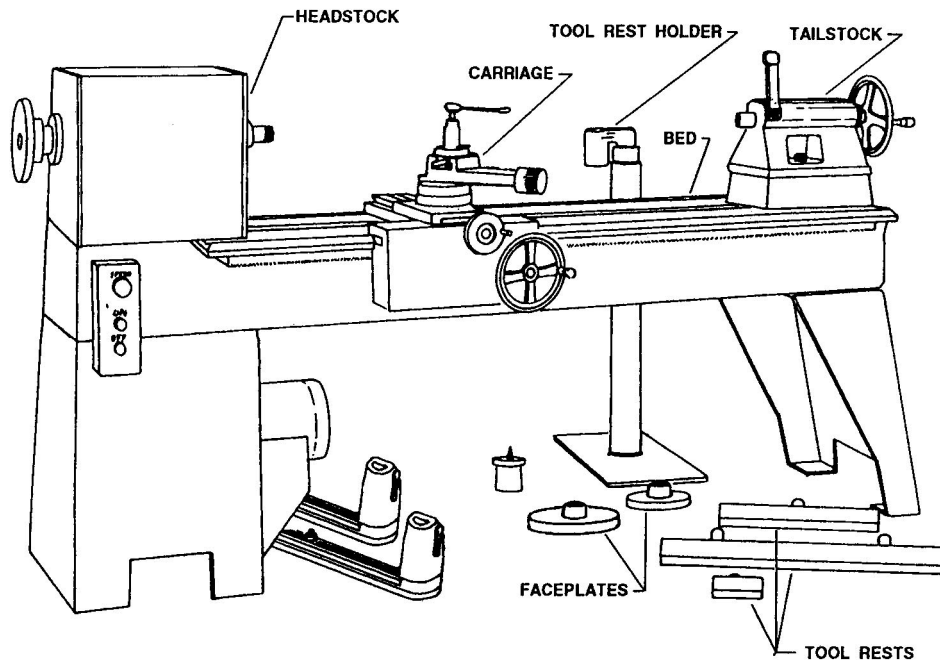
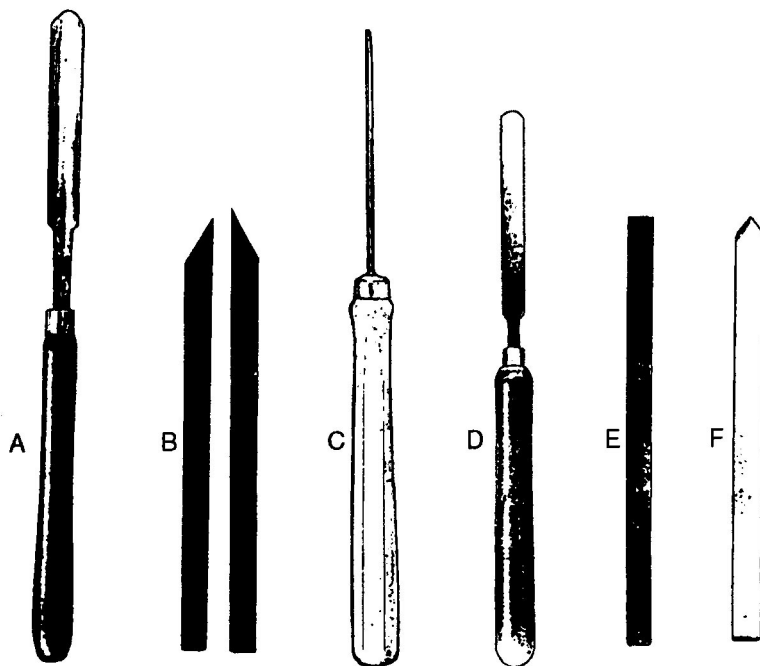

**Figure 3-5.—A woodturning lathe with accessories.**

Most large sizes of lathes are provided with a power-feeding carriage. A cone-pulley belt arrangement provides power from the motor, and trackways are cast to the inside of the bed for sliding the carriage back and forth. All machines have a metal bar that can be attached to the bed of the lathe between the operator and the work. This serves as a hand tool rest and provides support for the operator

in guiding tools along the work. It may be of any size and is adjustable to any desired position.

In lathe work, wood is rotated against the special cutting tools (illustrated in figure 3-6). These tools include turning gouges (view A); skew chisels (view B); parting tools (view C); round-nose (view D); square-nose (view E); and spear-point (view F)



**Figure 3-6.—Lathe cutting tools.**

chisels. Other cutting tools are tothing irons and auxiliary aids, such as calipers, dividers, and templates.

Turning gouges are used chiefly to rough out nearly all shapes in spindle turning. The gouge sizes vary from 1/8 to 2 or more inches, with 1/4-, 3/4-, and 1-inch sizes being most common.

Skew chisels are used for smoothing cuts to finish a surface, turning beads, trimming ends or shoulders, and for making V-cuts. They are made in sizes from 1/8 to 2 1/2 inches in width and in right-handed and left-handed pairs.

Parting tools are used to cut recesses or grooves with straight sides and a flat bottom, and also to cut off finished work from the faceplate. These tools are available in sizes ranging from 1/8 to 3/4 inch.

Scraping tools of various shapes are used for the most accurate turning work, especially for most faceplate turning. A few of the more commonly used shapes are illustrated in views D, E, and F of figure 3-6. The chisels shown in views B, E, and F are actually old jointer blades that have been ground to the required shape; the wood handles for these homemade chisels are not shown in the illustration.

A tothing iron (figure 3-7) is basically a square-nose turning chisel with a series of parallel grooves cut into the top surface of the iron. These turning tools we used for rough turning of segment work mounted on the face plate. The points of the tothing iron created by the parallel grooves serve as a series of spear point chisels (detail A); therefore, the tool is not likely to catch and dig into the work like a square-nose turning chisel. The tothing iron is made with course, medium, and fine parallel grooves and varies from 1/2 to 2 inches in width.

Lathe turning can be extremely dangerous. You therefore must use particular care in this work. Observe the following safety precautions:

- When starting the lathe motor, stand to one side. This helps you avoid the hazard of flying debris in the event of defective material.

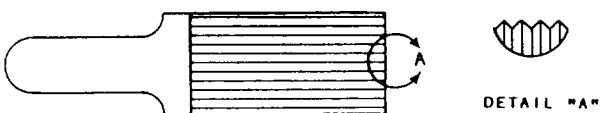

Figure 3-7.—Tothing iron lathe tool.

- The tool rest must be used when milling stock.
- Adjust and set the compound or tool rest for the start of the cut before turning the switch on.
- Take very light cuts, especially when using hand tools.
- Never attempt to use calipers on interrupted surfaces while the work is in motion.

**Jointer**

The jointer is a machine for power planing stock on faces, edges, and ends. The planing is done by a revolving butterhead equipped with two or more knives, as shown in figure 3-8. Tightening the set screws forces the throat piece against the knife for holding the knife in position. Loosening the set screws releases the knife for removal. The size of a jointer is designated by the width, in inches, of the butterhead; sizes range from 4 to 36 inches. A 6-inch jointer is shown in figure 3-9.

The principle on which the jointer functions is illustrated in figure 3-10. The table consists of two parts on either side of the butterhead. The stock is started on the infeed table and fed past the butterhead onto the outfeed table. The surface of the outfeed table must be exactly level with the highest point reached by the knife edges. The surface of the infeed table is depressed below the surface of the outfeed

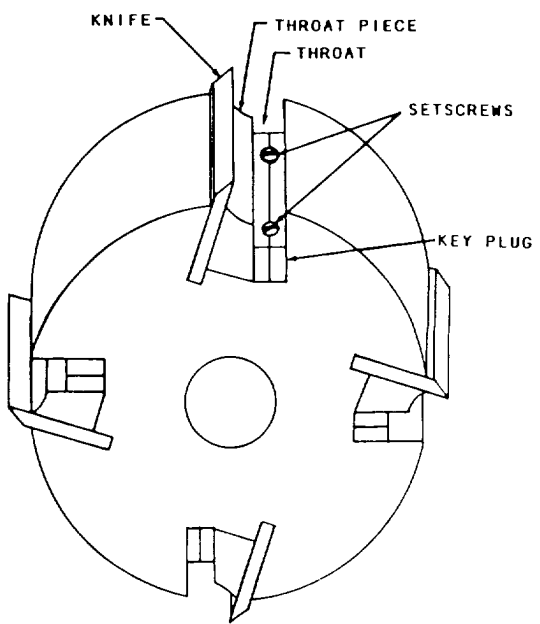
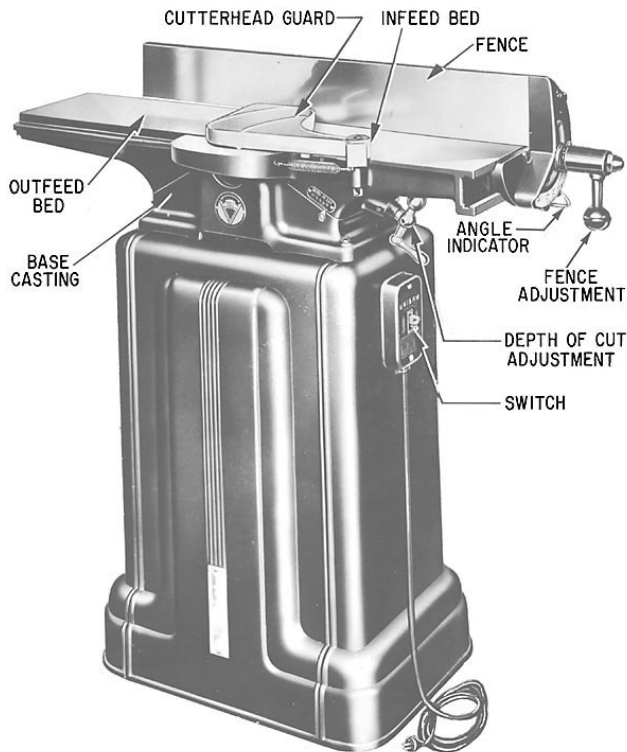

Figure 3-8.—Four-knife butterhead for a jointer.



**29.138**  
**Figure 3-9.—Six-inch jointer.**

table an amount equal to the desired depth of cut. The usual depth of cut is about 1/16 to 1/8 inch.

The level of the outfeed table must be frequently checked to ensure the surface is exactly even with the highest point reached by the knife edges. If the outfeed table is too high, the cut will become progressively more shallow as the piece is fed through. If the outfeed table is too low, the piece will drop downward as its end leaves the infeed table, and the cut for the last inch or so will be too deep.

To set the outfeed table to the correct height, first feed a piece of waste stock past the cutterhead until a few inches of it lie on the outfeed table. Then, stop the machine and look under the outfeed end of the piece. If the outfeed table is too low, there will be a space between the surface of the table and the lower face of the piece. Raise the outfeed table until this space is eliminated. If no space appears, lower the outfeed table until a space does appear. Now, run the stock back through the machine. If there is still a space, raise the table just enough to eliminate it.

Note that the cutterhead cuts toward the infeed table; therefore, to cut with the grain, you must place the piece with the grain running toward the infeed table. A piece is edged by feeding it through on edge with one of the faces

held against the fence. A piece is surfaced by feeding it through flat with one of the edges against the fence. However, this operation should, if possible, be limited to straightening the face of the stock. The fence can be set at 90° to produce squared faces and edges, or at any desired angle to produce beveled edges or ends.

Only sharp and evenly balanced knives should be used in a jointer cutting head. The knives must not be set to take too heavy a cut because a kickback is almost certain to result, especially if there is a knot or change of grain in the stock. The knives must be securely refastened after the machine has been standing in a cold building over the weekend.

Each hand-fed jointer should be equipped with a cylindrical cutting head, the throat of which should not exceed 7/16 inch in depth or 5/8 inch in width. It is strongly recommended that no cylinder be used in which the throat exceeds 3/8 inch in depth or 1/2 inch in width.

Each hand-fed jointer should have an automatic guard that covers all the sections of the head on the working side of the fence or gauge. The guard should automatically adjust horizontally for edge jointing and vertically for surface work, and it should remain in contact with the material at all times.

When operating the jointer, observe the following safety precautions:

- Always plane with the grain. A piece of wood planed against the grain on a jointer may be kicked back.
- Never place your hands directly over the inner cutterhead. Should the piece of wood kick

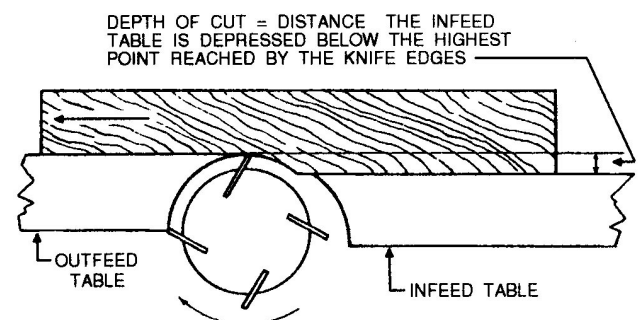

**Figure 3-10.—Operating principle of a jointer.**

back, your hands will drop on the blades. Start with your hands on the infeed bed. When the piece of wood is halfway through, reach around with your left hand and steady the piece of wood on the outfeed bed. Finish with both your hands on the outfeed bed.

- Never feed a piece of wood with your thumb or finger against the end of the piece of wood being fed into the jointer. Keep your hands on top of the wood at all times.
- Avoid jointing short pieces of wood whenever possible. Joint a longer piece of wood and then cut it to the desired size. If you must joint a piece of wood shorter than 18 inches, use a push stick to feed it through the jointer.
- Never use a jointer with dull cutter blades. Dull blades have a tendency to kick the piece, and a kickback is always dangerous.
- Keep the jointer table and the floor around the jointer clear of scraps, chips, and shavings. Always stop the jointer before brushing off and cleaning up those scraps, chips, and shavings.

- Never joint a piece of wood that contains loose knots.
- Keep your eyes and undivided attention on the jointer as you are working. Do not talk to anyone while operating the jointer.

Remember, the jointer is one of the most dangerous machines in the woodworking shop. Only experienced and responsible personnel should be allowed to operate it using the basic safety precautions provided above.

### Surfacer

A single surfacer (also called a single planer) is shown in figure 3-11. This machine surfaces stock on one face (the upper face) only. (Double surfacers, which surface both faces at the same time, are used only in large planing mills.)

The single surfacer cuts with a cutterhead like the one on the jointer, but, on the single surfacer, the cutterhead is located above instead of below the drive rollers. The part adjacent to the cutterhead is pressed down against the feed bed by the chip breakers (just ahead of the cutterhead) and the pressure bar (just behind the cutterhead). The pressure bar temporarily

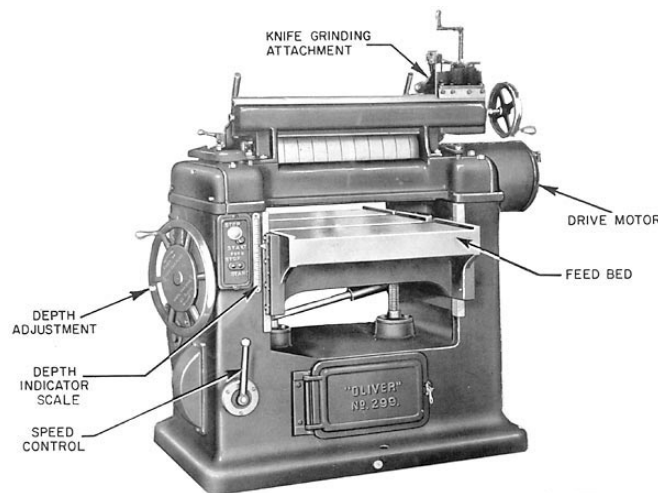

29.135

Figure 3-11.—Single surfacer.

straightens out any warp a piece may have; a piece that goes into the surfacer warped will come out still warped. This is not a defect in the machine; the surfacer is designed for surfacing only, not for truing warped stock. If true plane surfaces are desired, one face of the stock (the face that goes down in the surfacer) must be trued on the jointer before the piece is feed through the surfacer. If the face that goes down in the surfacer is true, the surfacer will plane the other face true.

Observe the following safety precautions when operating a surfacer:

- The cutting head should be covered by metal guards.
- Feed rolls should be guarded by a hood or a semicylindrical guard.
- Never force wood through the machine.
- If a piece of wood gets stuck, turn off the surfacer and lower the feed bed.



Figure 3-12.—Three-wing cutter for a shaper.

## Shaper

The shaper is designed primarily for edging curved stock and for cutting ornamental edges, as on moldings. It can also be used for rabbeting, grooving, fluting, and beading.

The flat cutter on a shaper is mounted on a vertical spindle and held in place by a hexagonal spindle nut. A grooved collar is placed below and above the cutter to receive the edges of the knives. Ball bearing collars are available for use as guides on irregular work where the fence is not used. The part of the edge that is to remain uncut runs against a ball bearing collar underneath the cutter, as shown in the bottom view of figure 3-12. A three-wing cutter (top view of figure 3-12) fits over the spindle. Cutters come with cutting edges in a great variety of shapes.

For shaping the side edges on a rectangular piece, a light-duty shaper has an adjustable fence, like the one shown on the shaper in figure 3-13. For shaping the end edges on a rectangular piece, a machine of this type has a sliding fence similar to the cutoff gauge on a circular saw. The sliding fence slides in the groove shown in the table top.

On larger machines, the fence consists of a board straightedge, clamped to the table with a hand screw,

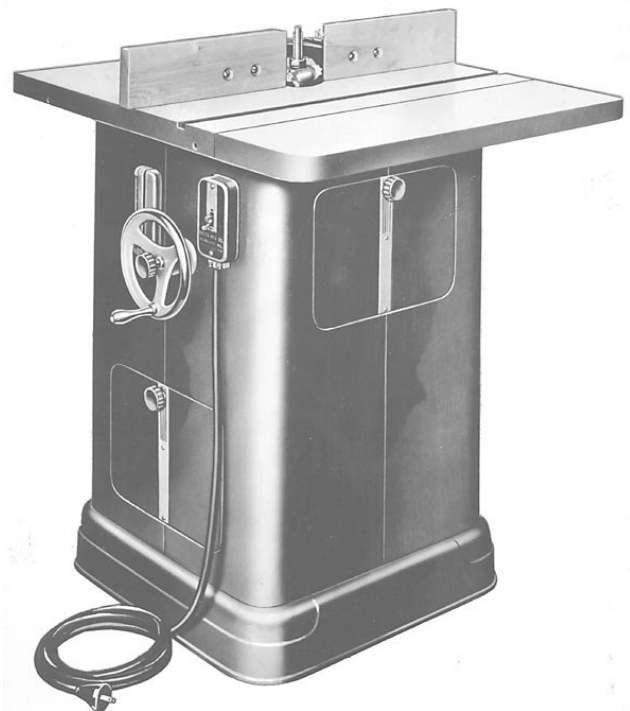

68.27

Figure 3-13.—Light-duty shaper with adjustable fence.

as shown in figure 3-14. A semicircular opening is sawed in the edge of the straightedge to accommodate the spindle and the cutters. Whenever possible, a guard of the type shown in the figure should be placed over the spindle.

For shaping curved edges, there are usually a couple of holes in the table, one on either side of the spindle, in which vertical starter pins can be inserted. When a curved edge is being shaped, the piece is guided by and steadied against the starter pin and the ball bearing collar on the spindle.

When operating a shaper, observe the following safety precautions:

- Like the jointer and surfacer, the shaper cuts toward the infeed side of the spindle, which is against the rotation of the spindle. Therefore, stock should be placed with the grain running toward the infeed side.
- Make sure the cutters are sharp and well secured.
- If curved or irregularly shaped edges are to be shaped, place the stock in position and make sure the collar will rub against the part of the edge, which should not be removed.
- Whenever the straight fence cannot be used, always use a starting pin in the table top.

- Never make extremely deep cuts.
- Make sure the shaper cutters rotate toward the work.
- Whenever possible, always use a guard, pressure bar, hold-down, or holding jig.
- If possible, place the cutter on the shaper spindle so that the cutting will be done on the lower side of the stock.
- Do not attempt to shape small pieces of wood.
- Check all adjustments before turning on the power.

### SAFETY NOTE

The spindle shaper is one of the most dangerous machines used in the shop. Use extreme caution at all times.

### PORTABLE HAND TOOLS

In addition to using power shop tools, you will be required to operate different types of portable hand tools in the field. You therefore need to understand the safety precautions associated with these.

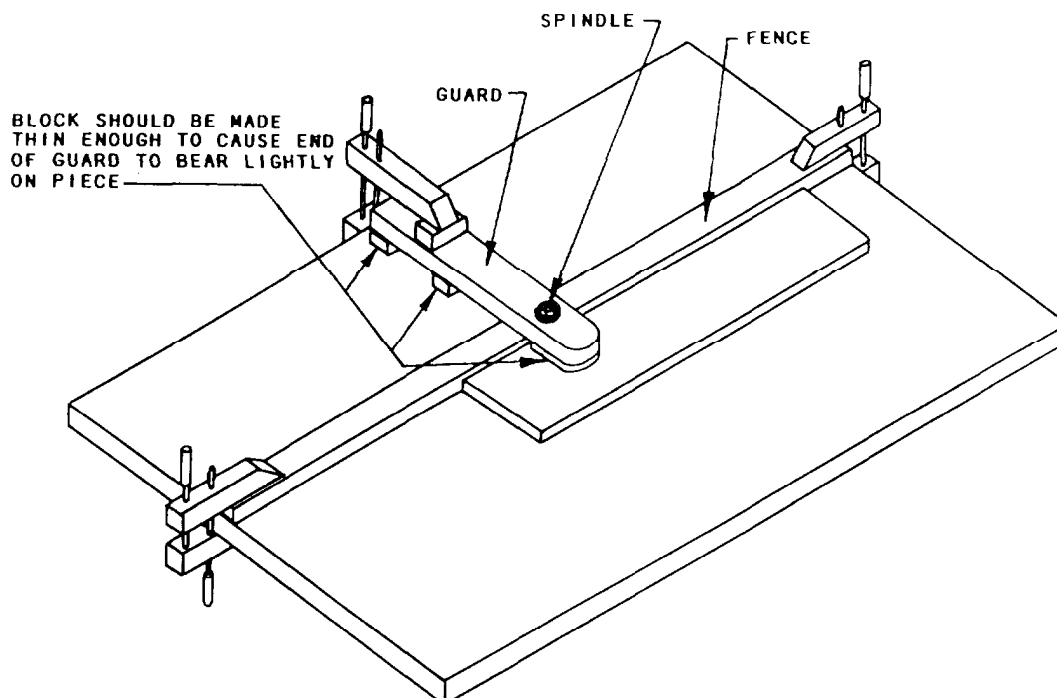

Figure 3-14.—Shaper table showing straightedge fence and guard.

## Portable Electric Circular Saw

The portable electric circular saw is used chiefly as a great labor-saving device in sawing wood framing members on the job. The size of a circular

saw is determined by the diameter of the largest blade it can use. The most commonly used circular saws are the 7 1/4- and 8 1/4-inch saws. There are two different types of electric saws, as shown in figure 3-15: the side-drive (view A) and the

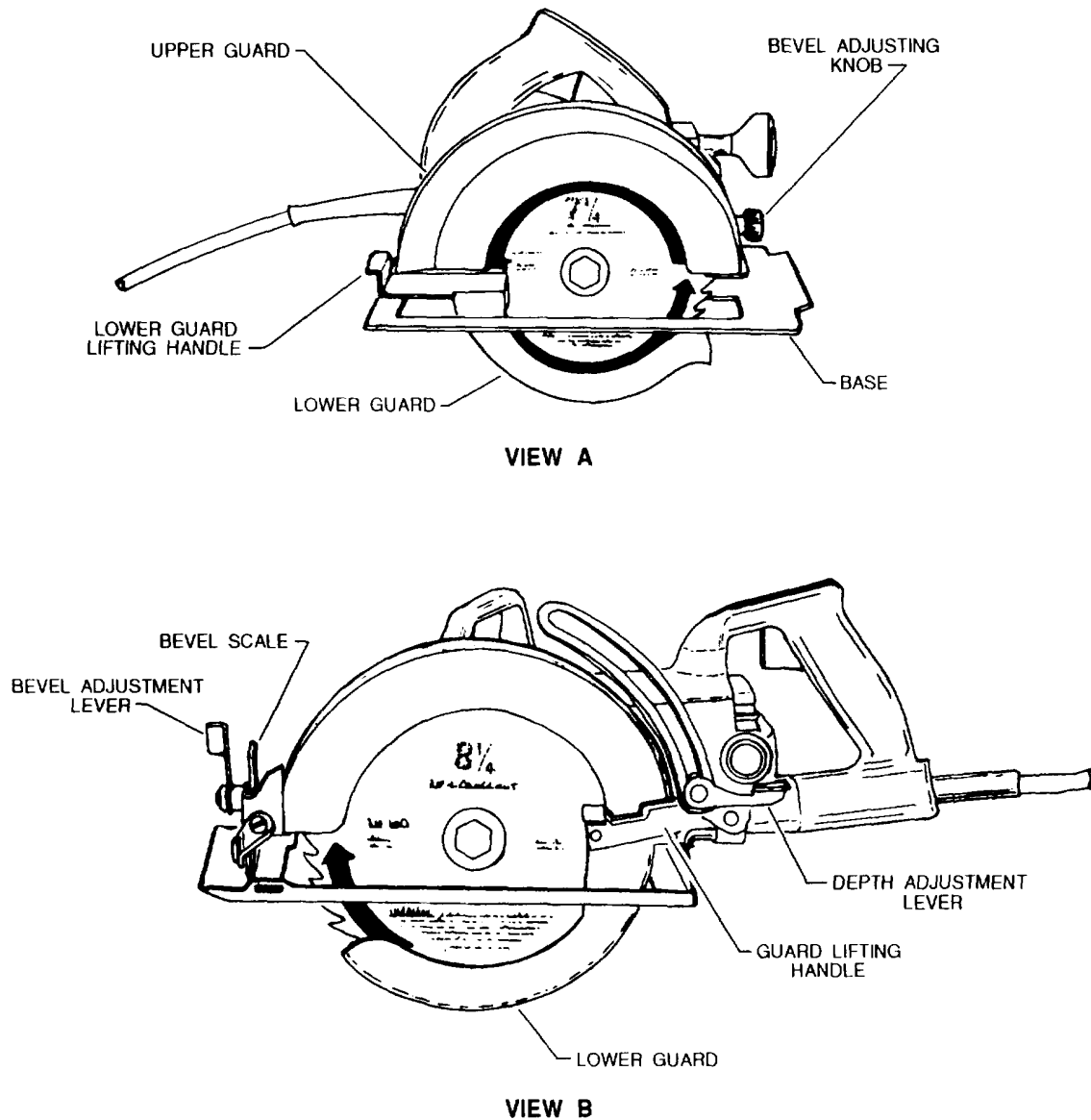

Figure 3-15.-Side-drive (view A) and worm-drive (view B) circular saws

worm-drive (view B). Circular saws can use many different types of cutting blades, some of which are shown in figure 3-16.

**COMBINATION CROSSCUT AND RIP BLADES.**— Combination blades are all-purpose blades for cutting thick and thin hardwoods and softwoods, both with or across the grain. They can also be used to cut plywood and hardboard.

**CROSSCUT BLADES.**— Crosscut blades have fine teeth that cut smoothly across the grain of both hardwood and softwood. These blades can be used for plywood, veneers, and hardboard.

**RIP BLADES.**— Rip blades have bigger teeth than combination blades, and should be used only to cut with the grain. A rip fence or guide will help you make an accurate cut with this type of blade.

**HOLLOW-GROUND BLADES.**— Hollow-ground blades have no set. They make the smoothest cuts on thick or thin stock. Wood cut with these blades requires little or no sanding.

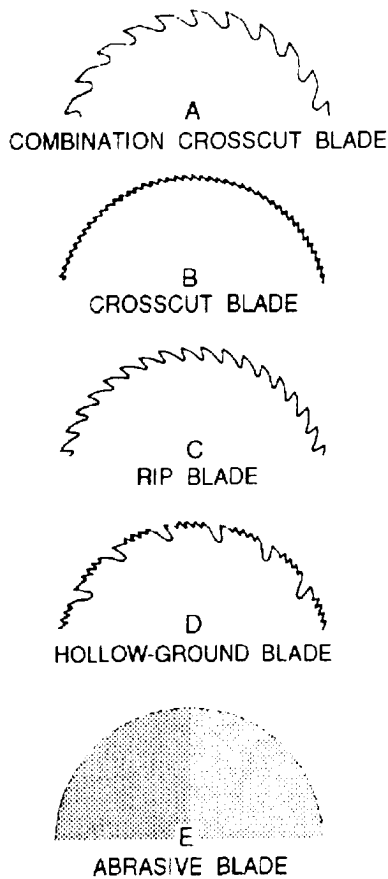

Figure 3-16.-Circular saw blades.

**ABRASIVE BLADES.**— Abrasive blades are used for cutting metal, masonry, and plastics. These blades are particularly useful for scoring bricks so they can be easily split.

Figure 3-17 shows how versatile the circular saw can be. To make an accurate ripping cut (view A), the

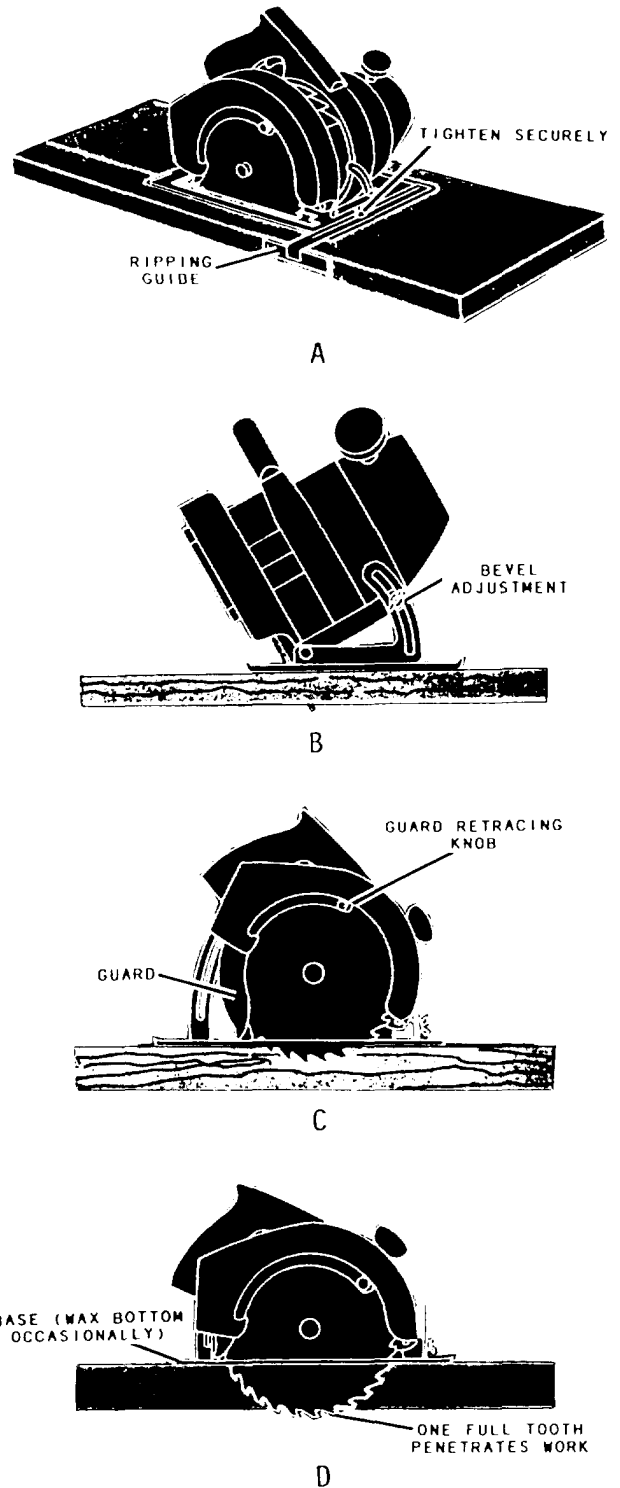

Figure 3-17.-Different ways to use a circular saw.



ripping guide is set a distance away from the saw equal to the width of the strip to be ripped off. It is then placed against the edge of the piece as a guide for the saw. To make a bevel angle cut up to 45° (view B), you just set the bevel adjustment knob to the angle you want and cut down the line. To make a pocket cut (views C and D), a square cut in the middle of a piece of material, you retract the guard back and tilt the saw so that it rests on the front of the base. Then, lowering the rear of the saw into the material, hold it there until it goes all the way through the wood. Then, follow your line.

Observe the following safety precautions when operating a circular saw:

- Don't force the saw through heavy cutting stock. If you do, you may overload the motor and damage it.
- Before using the saw, carefully examine the material to be cut and free it of nails or other metal objects. Cutting into or through knots should be avoided, if possible.
- Disconnect the saw from its power source before making any adjustments or repairs to the saw. This includes changing the blade.
- Make sure all circular saws are equipped with guards that automatically adjust themselves to the work when in use so that none of the teeth protrude above the work. Adjust the guard over the blade so that it slides out of its recess

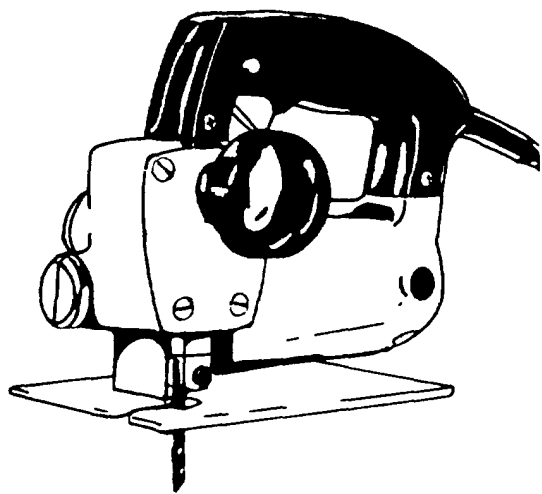

Figure 3-18.-Saber saw.

and covers the blade to the depth of the teeth when you lift the saw off the work.

- Wear goggles or face shields while using the saw and while cleaning up debris afterward.
- Grasp the saw with both hands and hold it firmly against the work. Take care to prevent the saw from breaking away from the work and thereby causing injury.
- Inspect the blade at frequent intervals and always after it has locked, pinched, or burned the work. Disconnect the saw from the power source before performing this inspection.
- Inspect daily the electric cords that you use for cuts or breaks. Before cutting boards, make sure the cord is not in the way of the blade.

### Saber Saw

The saber saw (figure 3-18) is a power-driven jigsaw that cuts smooth and decorative curves in wood and light metal. Most saber saws are light-duty machines and not designed for extremely fast cutting.

There are several different, easily interchangeable blades (figure 3-19) designed to operate in the saber saw. Some blades are designed for cutting wood and some for cutting metal.

The best way to learn how to handle this type of tool is to use it. Before trying to do a finished job with the saber saw, clamp down a piece of scrap plywood and draw some curved as well as straight lines to follow. You will develop your own way of



Figure 3-19.-Saber saw blades.

gripping the tool, which will be affected somewhat by the particular tool you are using. On some tools, for example, you will find guiding easier if you apply some downward pressure on the tool as you move it forward. If you don't use a firm grip, the tool will tend to vibrate excessively and roughen the cut. Do not force the cutting faster than the design of the blade allows or you will break the blade.

You can make a pocket cut with a saber saw just like you can with a circular saw, although you need to drill a starter hole to begin work. A saber saw can also make bevel-angle and curve cuts.

Observe the following safety precautions when operating the saber saw:

- Before working with the saber saw, be sure to remove your rings, watches, bracelets, and other jewelry.
- If you are wearing long sleeves, roll them up.
- Be sure the saber saw is properly grounded.
- Use the proper saw blade for the work to be done, and ensure the blade is securely locked in place.
- Be sure the material to be cut is free of any obstructions.
- Keep your full attention focused on the work being performed.
- Grip the handle of the saw firmly. Control the forward and turning movements with your free hand on the front guide.
- To start a cut, place the forward edge of the saw base on the edge of the material being worked, start the motor, and move the blade into the material.

### Portable Reciprocating Saw

The portable reciprocating saw (saw-all) (figure 3-20) is a heavy-duty power tool that you can use for a variety of woodworking maintenance work, remodeling, and roughing-in jobs. You can use it to cut rectangular openings, curved openings, along straight or curved lines, and flush.

Blades for reciprocating saws are made in a great variety of sizes and shapes. They vary in length from 2 1/2 to 12 inches and are made of high-speed steel or carbon steel. They have cutting edges similar to those shown in figure 3-19.

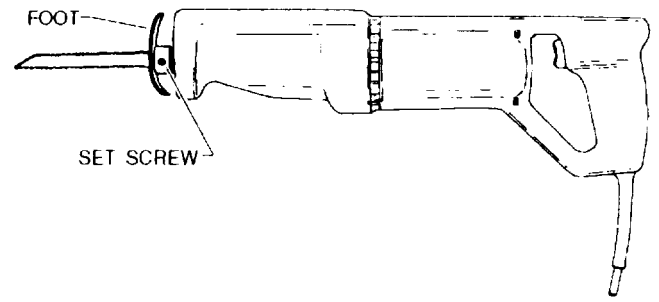

Figure 3-20.-Reciprocating saw.

Before operating this saw, be sure you are using a blade that is right for the job. The manufacturer's instruction manual shows the proper saw blade to use for a particular material. The blade must be pushed securely into the opening provided. Rock it slightly to ensure a correct fit, then tighten the setscrew.

To start a cut, place the saw blade near the material to be cut. Then, start the motor and move the blade into the material. Keep the cutting pressure constant, but do not overload the saw motor. Never reach underneath the material being cut.

Observe the following safety precautions when operating a reciprocating saw:

- Disconnect the saw when changing blades or making adjustments.

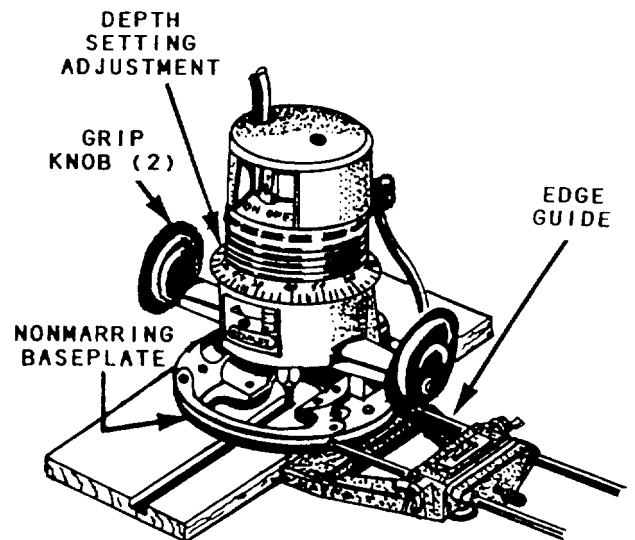

Figure 3-21.-Portable router with edge guide.

- Place the foot of the saw firmly on the stock before starting to cut.
- Don't cut curves sharper than the blade can handle.
- When cutting through a wall, make sure you don't cut electrical wires.

## Router

The router is a versatile portable power tool that can be used free hand or with jigs and attachments. Figure 3-21 shows a router typical of most models. It consists of a motor containing a chuck into which the router bits are attached. The motor slides into the base in a vertical position. By means of the depth adjustment ring, easy regulation of the depth of a cut is possible. Routers vary in size from 1/4 to 2 1/2 horsepower, and the motor speed varies from 18,000 to 27,000 rpm.

One of the most practical accessories for the router is the edge guide. It is used to guide the router in a straight line along the edge of the board. The edge guide is particularly useful for cutting grooves on long pieces of lumber. The two rods on the edge

guide slip into the two holes provided on the router base. The edge guide can be adjusted to move in or out along the two rods to obtain the desired lateral depth cut.

There are two classifications of router bits. Built-in, shank-type bits fit into the chuck of the router. Screw-type bits have a threaded hole through the center of the cutting head, which allows the cutting head to be screwed to the shank. Figure 3-22 shows a few of the most common router bits.

Observe the following safety precautions when operating a router:

- Before operating a router, be sure the work piece is well secured and free of obstruction.
- Make sure the router is disconnected from the power source before making any adjustment or changing bits.
- Don't overload the router when cutting the material.
- Use both hands to hold the router when cutting material.

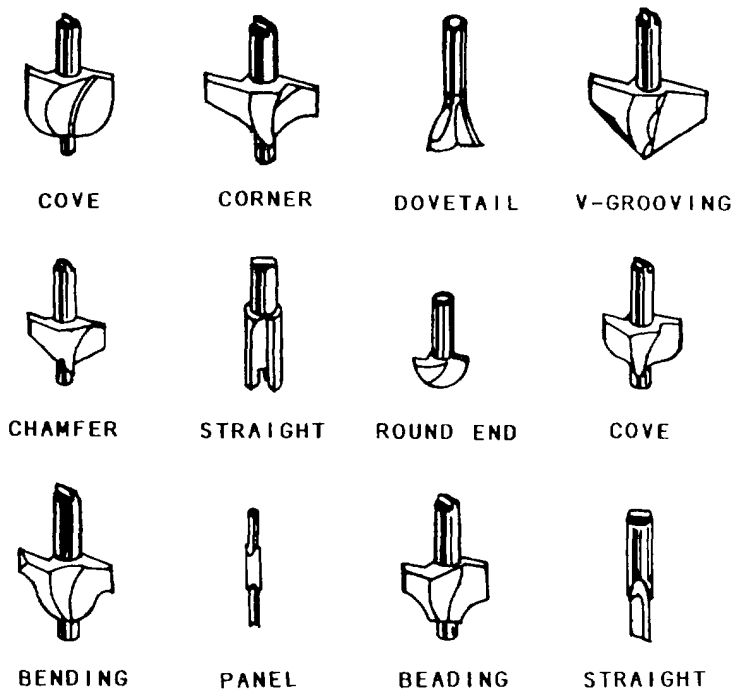

Figure 3-22.-Router bits.

## Portable Power Plane

The portable electric power plane (figure 3-23) is widely used for trimming panels, doors, frames, and so forth. It is a precision tool capable of exact depth of cut up to 3/16 inch on some of the heavier models. However, the maximum safe depth of cut on any model is 3/32 inch in any one pass.

The power plane is essentially a high-speed motor that drives a cutter bar, containing either straight or spiral blades, at high speed.

Operating the power plane is simply a matter of setting the depth of cut and passing the plane over the work. First, make careful measurements of the piece, where it is to fit, and determine how much material has to be removed. Then, the stock being planed should be held in a vise, clamped to the edge of a bench, or otherwise firmly held. Check the smoothness and straightness of all the edges.

If a smoothing cut is desired, make that cut first and then recheck the dimensions. Make as many passes as necessary with the plane to reach the desired dimensions, checking frequently so as not to remove too much material. The greater the depth of the cut, the slower you must feed the tool into the work. Feed pressure should be enough to keep the tool cutting, but not so much as to slow it down excessively. Keep wood chips off the work because they can mar the surface of the stock as the tool passes over them. Keep your hands away from the butterhead or blades when a cut is finished.

The L-shaped base, or fence, of the plane should be pressed snugly against the work when planing, assuring that the edge will be cut square. For bevel cuts, loosen the setscrew on the base, set the base at the desired bevel, and then retighten the setscrew.

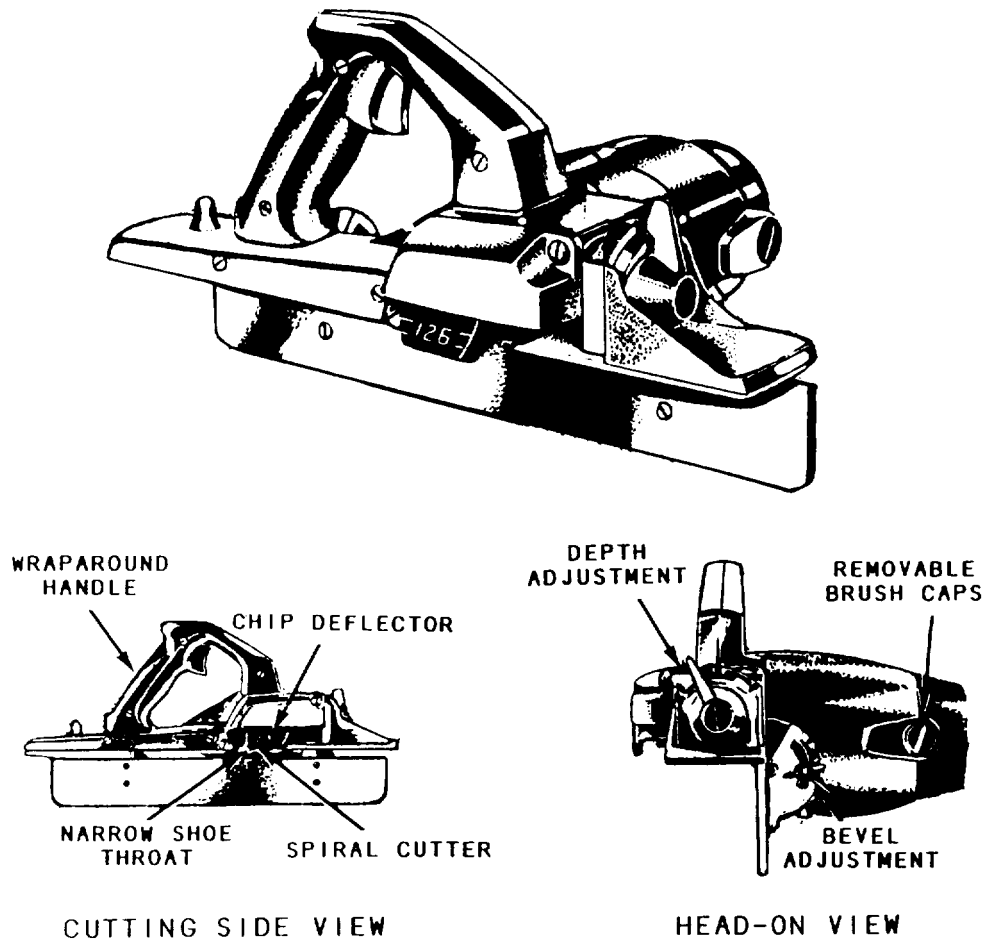

Figure 3-23.-Portable electric power plane.

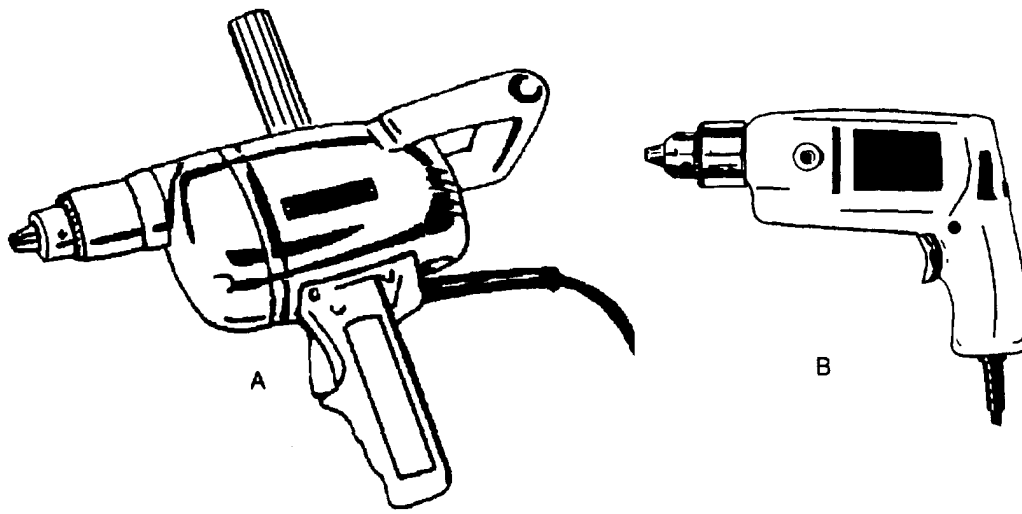

Figure 3-24.-Heavyduty 1/2-inch portable drill (view A) and light-duty 1/2-inch portable drill (view B).

Observe the following safety precautions when operating a portable power plane:

- Make sure that the plane is turned off before plugging it in.
- Make sure you disconnect the plug before making any adjustment.
- Don't attempt to power plane with one hand—you need two.
- Always clamp your work securely in the best position to perform the planing.
- When finished planing, make sure you disconnect the power cord.

### Portable Power Drills

Portable power drills have generally replaced hand tools for drilling holes because they are faster and more accurate. With variable-speed controls and special clutch-drive chucks, they can also be used as electric screwdrivers. More specialized power-driven screwdrivers are also available; these have greatly increased the efficiency of many fastening operations in construction work.

The two basic designs for portable electric drills (figure 3-24) are the spade design for heavy-duty construction (view A) and the pistol-grip design for lighter work (view B). Sizes of power drills are based on the diameter of the largest drill shank that will fit into the chuck of the drill.

The right-angle drill is a specialty drill used in plumbing and electrical work. It allows you to drill holes at a right angle to the drill body.

Observe the following safety precautions when operating a portable drill:

- Make sure that the drill or bit is securely mounted in the chuck.
- Hold the drill firmly as prescribed by the manufacturer of the drill.
- When feeding the drill into the material, vary the pressure you apply to accommodate the different kinds of stock. Be careful not to bind the drill or bit.
- When drilling a deep hole, withdraw the drill several times to clean the drill bit.

### Portable Sanders

There are three types of portable sanders: belt, disk, and finish sanders. When using a belt sander (figure 3-25), be careful not to gouge the wood. The size of a belt sander is usually identified by the width of its sanding belt. Belt widths on heavier duty

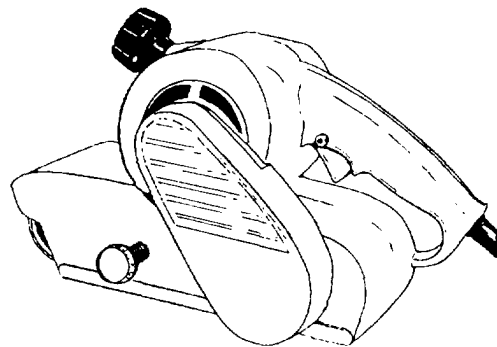

Figure 3-25.-Belt sander.

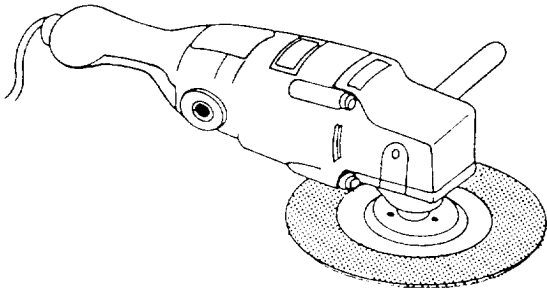

Figure 3-26.-Portable disk sander.

models are usually 3 or 4 inches. Depending on the make and model, belt lengths vary from 21 to 27 inches. Different grades of abrasives are available.

The disk sander (figure 3-26) is a useful tool for removing old finish, paint, and varnish from siding, wood flooring, and concrete. For best results with a disk sander, tip the machine lightly with just enough pressure to bend the disk. Use a long, sweeping motion, back and forth, advancing along the surface. When using a disk sander, always operate it with both hands.

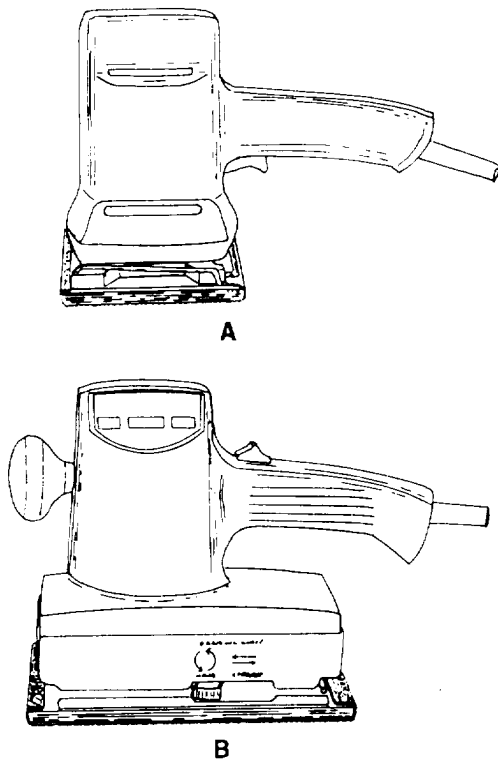

Figure 3-27.-Two types of finish sanders: orbital (view A) and oscillating (view B).

The finish sander (figure 3-27) is used for light and fine sanding. Two kinds of finish sanders are available. One operates with an orbital (circular) motion (view A), and the other has an oscillating (back and forth) movement (view B). Finish sanders use regular abrasive paper (sandpaper) cut to size from full sheets.

Observe the following safety tips when operating portable sanders:

- Make sure the sander is off before plugging it in.
- Make sure that you use two hands if using the belt sander.
- Don't press down on the sander. The weight of the sander is enough to sand the material.
- Make sure the sander is disconnected when changing sandpaper.
- Keep the electrical cord away from the area being sanded.

### Power Nailers and Staplers

There is a wide variety of power nailers and staplers available. A typical example of each is shown in figure 3-28. A heavy-duty nailer is used for

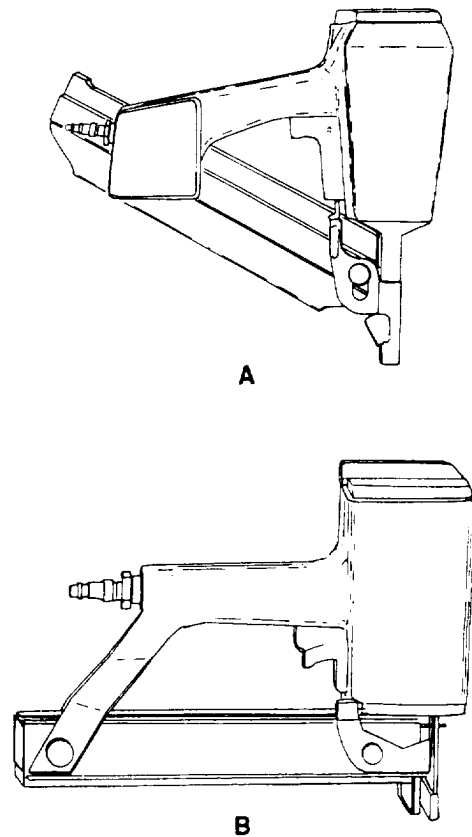

Figure 3-28.-Heavy-duty pneumatic nailer (view A) and pneumatic stapler (view B).

framing or sheathing work; finish nailers are used for paneling or trimming. There is also a wide variety of staplers that you can use for jobs, such as fastening sheathing, decking, or roofing. These tools are often driven by compressed air. The amount of pneumatic, or air, pressure required to operate the tool depends on the size of the tool and the type of operation you are performing. Check the manufacturer's manual for the proper air pressure to operate the tool.

The power nailer and power stapler are great timesaving tools, but they are also **very dangerous** tools. Observe the following safety precautions when using them:

- Use the correct air pressure for the particular tool and job.
- Use the right nailer or stapler for the job and also the correct nails and staples.
- Keep the nose of the tool pointed away from your body.

- When you are not using a nailer or stapler or if you are loading one, **disconnect the air supply**.

## MATERIALS

*LEARNING OBJECTIVE: Upon completing this section, you should be able to identify the types, sources, uses, and characteristics of the common woods used on various construction projects.*

Of all the different construction materials, wood is probably the most often used and perhaps the most important. The variety of uses of wood is practically unlimited. Few Seabee construction projects are accomplished without using some type of wood. It is used for permanent structures as well as concrete forms, scaffolding, shoring, and bracing, which may be used again and again. The types, sources, uses, and characteristics of common woods are given in table 3-1. The types of classifications of wood for a large project are usually designated in the project specifications and included in the project drawings.

Table 3-1.-Common Woods

TYPES	SOURCES	USES	CHARACTERISTICS
ASH	East of Rockies	Oars, boat thwarts, benches, gratings, hammer handles, cabinets, ball bats, wagon construction, farm implements	Strong, heavy, hard, tough, elastic, close straight grain, shrinks very little, takes excellent finish, lasts well
BEECH	East of Mississippi and southeastern Canada	Cabinetwork, imitation mahogany furniture, wood dowels, capping, boat trim, interior finish, tool handles, turnery, shoe lasts, carving, flooring	Similar to birch but not so durable when exposed to weather, shrinks and checks considerably, close grain, light or dark red color
BIRCH	East of Mississippi River and north of gulf coast states, southeast Canada, and Newfoundland	Cabinetwork, imitation mahogany furniture, wood dowels, capping, boat trim, interior finish, tool handles, turnery, carving	Hard, durable, fine grain, even texture, heavy, stiff, strong, tough, takes high polish, works easily, forms excellent base for white enamel finish, but not durable when exposed. Heartwood is light to dark reddish brown in color

Table 3-1.-Common Woods-continued

TYPES	SOURCES	USES	CHARACTERISTICS
<b>BUTTERNUT</b>	Southern Canada, Minnesota, eastern U.S. as far south as Alabama and Florida	Toys, altars, woodenware, millwork, interior trim, furniture, boats, scientific instruments	Very much like walnut in color but softer, not so soft as white pine and basswood, easy to work, coarse grained, fairly strong
<b>DOUGLAS FIR</b>	Pacific coast and British Columbia	Deck planking on large ships, shores, strongbacks, plugs, filling pieces and bulkheads of small boats, building construction, dimension timber, plywood	Excellent structural lumber, strong, easy to work, clear straight grained, soft but brittle. Heartwood is durable in contact with ground, best structural timber of northwest
<b>ELM</b>	States east of Colorado	Agricultural implements, wheel-stock, boats, furniture, crossties, posts, poles	Slippery, heavy, hard, tough, durable, difficult to split, not resistant to decay
<b>HICKORY</b>	Arkansas, Tennessee, Ohio, and Kentucky	Tools, handles, wagon stock, hoops, baskets, vehicles, wagon spokes	Very heavy, hard, stronger and tougher than other native woods, but checks, shrinks, difficult to work, subject to decay and insect attack
<b>MAPLE</b>	All states east of Colorado and Southern Canada	Excellent furniture, high-grade floors, tool handles, ship construction, crossties, counter tops, bowling pins	Fine grained, grain often curly or "Birds's Eyes," heavy, tough, hard, strong, rather easy to work, but not durable. Heartwood is light brown, sap wood is nearly white
<b>LIVE OAK</b>	Southern Atlantic and gulf coasts of U. S., Oregon, and California	Implements, wagons, ship-building	Very heavy, hard, tough, strong, durable, difficult to work, light brown or yellow sap wood nearly white
<b>MAHOGANY</b>	Honduras, Mexico, Central America, Florida, West Indies, Central Africa, and other tropical sections	Furniture, boats, decks, fixtures, interior trim in expensive homes, musical instruments	Brown to red color, one of most useful of cabinet woods, hard, durable, does not split badly, open grained, takes beautiful finish when grain is filled but checks, swells, shrinks, warps slightly
<b>NORWAY PINE</b>	States bordering Great Lakes	Dimension timber, masts, spars, piling, interior trim	Light, fairly hard, strong, not durable in contact with ground



Table 3-1.-Common Woods-Continued

TYPES	SOURCES	USES	CHARACTERISTICS
<b>PHILIPPINE MAHOGANY</b>	Philippine Islands	Pleasure boats, medium-grade furniture, interior trim	Not a true mahogany, shrinks, expands, splits, warps, but available in long, wide, clear boards
<b>POPLAR</b>	Virginias, Tennessee, Kentucky, and Mississippi Valley	Low-grade furniture, cheaply constructed buildings, interior finish, shelving drawers, boxes	Soft, cheap, obtainable in wide boards, warps, shrinks, rots easily, light, brittle, weak, but works easily and holds nails well, fine-textured
<b>RED CEDAR</b>	East of Colorado and north of Florida	Mothproof chests, lining for linen closets, sills, and other uses similar to white cedar	Very light; soft, weak, brittle, low shrinkage, great durability, fragrant scent, generally knotty, beautiful when finished in natural color, easily worked
<b>RED OAK</b>	Virginias, Tennessee, Arkansas, Kentucky, Ohio, Missouri, Maryland	Interior finish, furniture, cabinets, millwork, crossties when preserved	Tends to warp, coarse grain, does not last well when exposed to weather, porous, easily impregnated with preservative, heavy, tough, strong
<b>REDWOOD</b>	California	General construction, tanks, paneling	Inferior to yellow pine and fir in strength, shrinks and splits little, extremely soft, light, straight grained, very durable, exceptionally resistant to decay
<b>SPRUCE</b>	New York, New England, West Virginia, central Canada, Great Lakes states, Idaho, Washington, Oregon	Railway ties, resonance wood, piles, airplanes, oars, masts, spars, baskets	Light, soft, low strength, fair durability, close grain, yellowish, sap wood indistinct
<b>SUGAR PINE</b>	California and Oregon	Same as white pine	Very light, soft, resembles white pine
<b>TEAK</b>	India, Burma, Thailand, and Java	Deck planking, shaft logs for small boats	Light brown color, strong, easily worked, durable, resistant to moisture damage

Table 3-1.-Common Woods-Continued

TYPES	SOURCES	USES	CHARACTERISTICS
<b>WALNUT</b>	Eastern half of U.S. except southern Atlantic and gulf coasts, some in New Mexico, Arizona, California	Expensive furniture, cabinets, interior woodwork, gun stocks, tool handles, airplane propellers, fine boats, musical instruments	Fine cabinet wood, coarse grained but takes beautiful finish when pores closed with wood filler, medium weight, hard, strong, easily worked, dark chocolate color, does not warp or check brittle
<b>WHITE CEDAR</b>	Eastern coast of U. S., and around Great Lakes	Boat planking, railroad ties, shingles, siding, posts, poles	Soft, lightweight, close grained, exceptionally durable when exposed to water, not strong enough for building construction, brittle, low shrinkage, fragment, generally knotty
<b>WHITE OAK</b>	The Virginias, Tennessee, Arkansas, Kentucky, Ohio, Missouri, Maryland, and Indiana	Boat and ship stems, stern-posts, knees, sheer strakes, fenders, capping, transoms, shaft logs, framing for buildings, strong furniture, tool handles, crossties, agricultural implements, fence posts	Heavy, hard, strong, medium coarse grain, tough, dense, most durable of hardwoods, elastic, rather easy to work, but shrinks and likely to check. Light brownish grey in color with reddish tinge, medullary rays are large and outstanding and present beautiful figures when quarter sawed, receives high polish
<b>WHITE PINE</b>	Minnesota, Wisconsin, Maine, Michigan, Idaho, Montana, Washington, Oregon, and California	Patterns, any interior job or exterior job that doesn't require maximum strength, window sash, interior trim, millwork, cabinets, cornices	Easy to work, fine grain, free of knots, takes excellent finish, durable when exposed to water, expands when wet, shrinks when dry, soft, white, nails without splitting, not very strong, straight grained
<b>YELLOW PINE</b>	Virginia to Texas	Most important lumber for heavy construction and exterior work, keelsons, risings, filling pieces, clamps, floors, bulkheads of small boats, shores, wedges, plugs, strongbacks, staging, joists, posts, piling, ties, paving blocks	Hard, strong, heartwood is durable in the ground, grain varies, heavy, tough, reddish brown in color, resinous, medullary rays well marked

## LUMBER

The terms "wood" "lumber," and "timber" are often spoken of or written in ways to suggest that their meanings are alike or nearly so. But in the Builder's language, the terms have distinct, separate meanings. Wood is the hard, fibrous substance that forms the major part of the trunk and branches of a tree. Lumber is wood that has been cut and surfaced for use in construction work. Timber is lumber that is 5 inches or more in both thickness and width.

### SEASONING OF LUMBER

Seasoning of lumber is the result of removing moisture from the small and large cells of wood—drying. The advantages of seasoning lumber are to reduce its weight; increase its strength and resistance to decay; and decrease shrinkage, which tends to avoid checking and warping after lumber is placed. A seldom used and rather slow method of seasoning lumber is air-drying in a shed or stacking in the open

until dry. A faster method, known as kiln drying, has lumber placed in a large oven or kiln and dried with heat, supplied by gas- or oil-fired burners. Lumber is considered dry enough for most uses when its moisture content has been reduced to about 12 or 15 percent. As a Builder, you will learn to judge the dryness of lumber by its color, weight, smell, and feel. Also, after the lumber is cut, you will be able to judge the moisture content by looking at the shavings and chips.

### DEFECTS AND BLEMISHES

A defect in lumber is any flaw that tends to affect the strength, durability, or utility value of the lumber. A blemish is a flaw that mars only the appearance of lumber. However, a blemish that affects the utility value of lumber is also considered to be a defect; for example, a tight knot that mars the appearance of lumber intended for fine cabinet work.

Various flaws apparent in lumber are listed in table 3-2.

Table 3-2.—Wood Defects and Blemishes

COMMON NAME	DESCRIPTION
Bark Pocket	Patch of bark over which the tree has grown, and has entirely or almost entirely enclosed
Check	Separation along the lengthwise grain, caused by too rapid or nonuniform drying
Cross Grain	Grain does not run parallel to or spiral around the lengthwise axis
Decay	Deterioration caused by various fungi
Knot	Root section of a branch that may appear on a surface in cross section or lengthwise. A cross-sectional knot maybe loose or tight. A lengthwise knot is called a spike knot
Pitch Pocket	Deposit of solid or liquid pitch enclosed in the wood
Shake	Separation along the lengthwise grain that exists before the tree is cut. A heart shake moves outward from the center of the tree and is caused by decay at the center of the trunk. A wind shake follows the circular lines of the annual rings; its cause is not definitely known
Wane	Flaw in an edge or corner of a board or timber. It is caused by the presence of bark or lack of wood in that part
Warp	Twist or curve caused by shrinkage that develops in a once flat or straight board
Blue Stain	A blemish caused by a mold fungus; it does not weaken the wood

## CLASSIFICATION OF LUMBER

Trees are classified as either softwood or hardwood (table 3-3). Therefore, all lumber is referred to as either “softwood” or “hardwood.” The terms “softwood” and “hardwood” can be confusing since some softwood lumber is harder than some hardwood lumber. Generally, however, hardwoods are more dense and harder than softwoods. In addition, lumber can be further classified by the name of the tree from which it comes. For example, Douglas fir lumber comes from a Douglas fir tree; walnut lumber comes from a walnut tree, and so forth.

The quality of softwood lumber is classified according to its intended use as being yard, structural, factory, or shop lumber. Yard lumber consists of those grades, sizes, and patterns generally intended for ordinary building purposes. Structural lumber is 2 or more inches in nominal thickness and width and is used where strength is required. Factory and shop lumber are used primarily for building cabinets and interior finish work.

Lumber manufacturing classifications consist of rough dressed (surfaced) and worked lumber. Rough lumber has not been dressed but has been sawed, edged, and trimmed. Dressed lumber is rough lumber

that has been planed on one or more sides to attain smoothness and uniformity. Worked lumber, in addition to being dressed, has also been matched, shiplapped, or patterned. Matched lumber is tongue and groove, either sides or ends or both. Shiplapped lumber has been rabbeted on both edges to provide a close-lapped joint. Patterned lumber is designed to a pattern or molded form.

### Softwood Grading

The grade of a piece of lumber is based on its strength, stiffness, and appearance. A high grade of lumber has very few knots or other blemishes. A low grade of lumber may have knotholes and many loose knots. The lowest grades are apt to have splits, checks, honeycombs, and some warpage. The grade of lumber to be used on any construction job is usually stated in the specifications for a set of blueprints. Basic classifications of softwood grading include boards, dimension, and timbers. The grades within these classifications are shown in table 3-4.

Lumber is graded for quality in accordance with American Lumber Standards set by the National Bureau of Standards for the U.S. Department of Commerce. The major quality grades, in descending order of quality, are select lumber and common

Table 3-3.-Different Types of Softwoods and Hardwoods

SOFTWOODS	HARDWOODS
Douglas fir Southern pine Western larch	Basswood Willow American elm
Hemlock White fir Spruce	Mahogany* Sweet gum White ash*
Ponderosa pine Western red cedar Redwood	Beech Birch Cherry
Cypress White pine Sugar pine	Maple Oak* Walnut*

\*Open-grained wood

Table 3-4.-Softwood Lumber Grades

<b>BOARDS</b>			
<b>APPEARANCE GRADES</b>	<b>SELECTS</b>	B & BETTER C SELECT D SELECT	(IWP—SUPREME) (IWP—CHOICE) (IWP—QUALITY)
	<b>FINISH</b>	SUPERIOR PRIME E	
	<b>PANELING</b>	CLEAR (ANY SELECT OR FINISH GRADE) NO. 2, 3 COMMON SELECTED FOR KNOTTY PANELING	
	<b>SIDING (BEVEL, BUNGALOW)</b>	SUPERIOR PRIME	
<b>BOARDS SHEATHING</b>		NO. 1 COMMON (IWP—COLONIAL) NO. 2 COMMON (IWP—STERLING) NO. 3 COMMON (IWP—STANDARD) NO. 4 COMMON (IWP—UTILITY)	SELECT MERCHANTABLE CONSTRUCTION STANDARD UTILITY
<b>DIMENSION</b>			
<b>LIGHT FRAMING</b> 2 in. to 4 in. Thick 2 in. to 4 in. Wide	CONSTRUCTION STANDARD UTILITY ECONOMY	This category for use where high strength values are <b>NOT</b> required; such as studs, plates, sills, cripples, blocking, etc.	
	STUD ECONOMY STUD	An optional all-purpose grade limited to 10 feet and shorter. Characteristics affecting strength and stiffness values are limited so that the Stud grade is suitable for all stud uses, including load bearing walls.	
<b>STRUCTURAL LIGHT FRAMING</b> 2 in. to 4 in. Thick 2 in. to 4 in. Wide	SELECT STRUCTURAL NO. 1 NO. 2 NO. 3 ECONOMY	These grades are designed to fit those engineering applications where higher bending strength ratios are needed in light framing sizes. Typical uses would be for trusses, concrete pier wall forms, etc.	
<b>STRUCTURAL JOISTS &amp; PLANKS</b> 2 in. to 4 in. Thick 6 in. and Wider	SELECT STRUCTURAL NO. 1 NO. 2 NO. 3 ECONOMY	These grades are designed especially to fit in engineering applications for lumber 6 inches and wider, such as joists, rafters and general-framing uses.	
<b>TIMBERS</b>			
<b>BEAMS &amp; STRINGERS</b>	SELECT STRUCTURAL NO. 1 NO. 2 (NO. 1 MINING) NO. 3 (NO. 2 MINING)	<b>POSTS &amp; TIMBERS</b>	SELECT STRUCTURAL NO. 1 NO. 2 (NO. 1 MINING) NO. 3 (NO. 2 MINING)

lumber. Table 3-5 lists the subdivisions for each grade in descending order of quality.

Lumber in this group is expected to yield 6623 percent clear cuttings.

### Hardwood Grades

Grades of hardwood lumber are established by the National Hardwood Lumber Association. FAS (firsts and seconds) is the best grade. It specifies that pieces be no less than 6-inches wide by 8-feet long and yield at least 83 1/3 percent clear cuttings. The next lower grade is selects, which permits pieces 4-inches wide by 6-feet long. A still lower grade is No. 1 common.

### Lumber Sizes

Standard lumber sizes have been established in the United States for uniformity in planning structures and in ordering materials. Lumber is identified by nominal sizes. The nominal size of a piece of lumber is larger than the actual dressed dimensions. Referring to table 3-6, you can determine the common widths and thicknesses of lumber in their nominal and dressed dimensions.

Table 3-5.-Grades and Subdivisions of Lumber

<b>SELECT LUMBER</b>	
<b>Grade A</b>	This lumber is practically free of defects and blemishes
<b>Grade B</b>	This lumber contains a few minor blemishes
<b>Grade C</b>	This lumber contains more numerous and more significant blemishes than grade B. It must be capable of being easily and thoroughly concealed with paint
<b>Grade D</b>	This lumber contains more numerous and more significant blemishes than grade C, but it is still capable of presenting a satisfactory appearance when painted
<b>COMMON LUMBER</b>	
<b>No. 1</b>	Sound, tight-knotted stock containing only a few minor defects. Must be suitable for use as watertight lumber
<b>No. 2</b>	Contains a limited number of significant defects but no knotholes or other serious defects. Must be suitable for use as grain-tight lumber
<b>No. 3</b>	Contains a few defects that are larger and coarser than those in No. 2 common; for example, occasional knotholes
<b>No. 4</b>	Low-quality material containing serious defects like knotholes, checks, shakes, and decay
<b>No. 5</b>	Capable only of holding together under ordinary handling

Table 3-6.-Nominal and Dressed Sizes of Lumber

NOMINAL SIZE (INCHES)	DRESSED SIZE (INCHES)
1 × 3	3/4 × 2 1/2
1 × 4	3/4 × 3 1/2
1 × 6	3/4 × 5 1/2
1 × 8	3/4 × 7 1/4
1 × 10	3/4 × 9 1/4
1 × 12	3/4 × 11 1/4
2 × 4	1 1/2 × 3 1/2
2 × 6	1 1/2 × 5 1/2
2 × 8	1 1/2 × 7 1/4
2 × 10	1 1/2 × 9 1/4
2 × 12	1 1/2 × 11 1/4
3 × 8	2 1/2 × 7 1/4
3 × 12	2 1/2 × 11 1/4
4 × 12	3 1/2 × 11 1/4
4 × 16	3 1/2 × 15 1/4
6 × 12	5 1/2 × 11 1/2
6 × 16	5 1/2 × 15 1/2
6 × 18	5 1/2 × 17 1/2
8 × 16	7 1/2 × 15 1/2
8 × 20	7 1/2 × 19 1/2
8 × 24	7 1/2 × 23 1/2

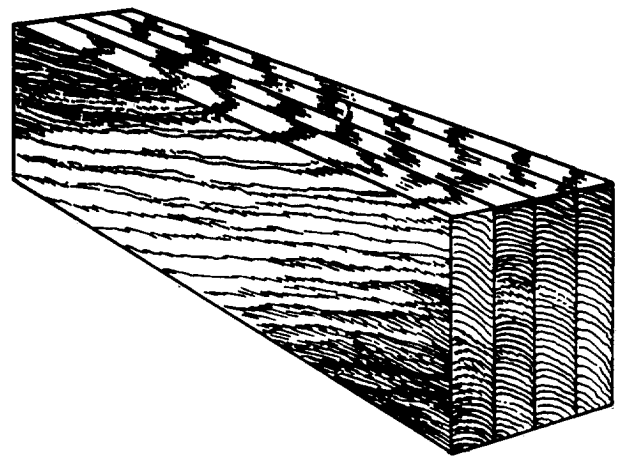

Figure 3-29.-Laminated lumber.

### LAMINATED LUMBER

Laminated lumber (figure 3-29) is made of several pieces of lumber held together as a single unit, a process called lamination. Usually 1 1/2-inches thick, the pieces are nailed, bolted, or glued together with the grain of all pieces running parallel. Laminating greatly increases the load-carrying capacity and rigidity of the wood. When extra length is needed, the pieces are spliced—with the splices staggered so that no two adjacent laminations are spliced at the same point. Built-up beams and girders are examples. They are built as shown in figure 3-30, usually nailed or bolted together, and spliced.

Lamination can be used independently or with other materials in the construction of a structural unit. Trusses can be made with lamination for the chords and sawed

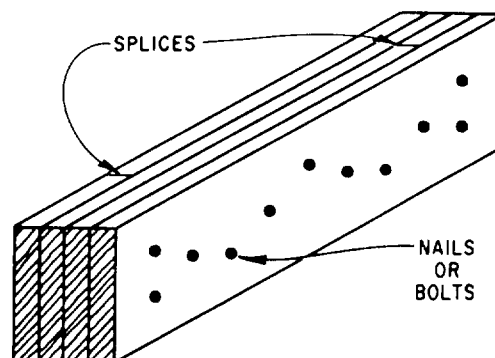

Figure 3-30.-Built-up beam.

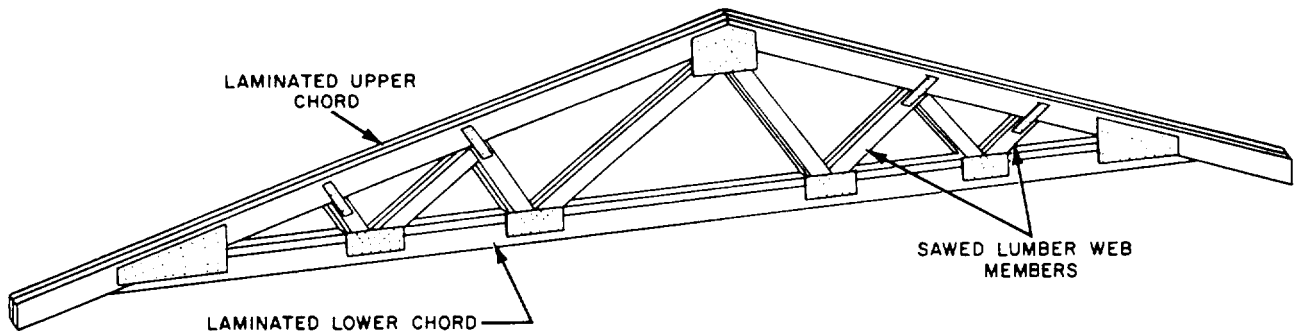

Figure 3-31.-Truss using laminated and sawed lumber.

lumber, or for the web members (figure 3-31). Special beams can be constructed with lamination for the flanges and plywood or sawed lumber, for the web, as shown in figure 3-32. Units, such as plywood box beams and stressed skin panels, can contain both plywood and lamination (figure 3-33).

Probably the greatest use of lamination is in the fabrication of large beams and arches. Beams with spans in excess of 100 feet and depths of 8 1/2 feet have been constructed using 2-inch boards. Laminations this large are factory produced. They are glued together under pressure. Most laminations are spliced using scarf joints (figure 3-34), and the entire piece is dressed to ensure uniform thickness and

width. The depth of the lamination is placed in a horizontal position and is usually the full width of the beam (figure 3-35).

### PLYWOOD

Plywood is constructed by gluing together a number of layers (plies) of wood with the grain direction turned at right angles in each successive layer. This design feature makes plywood highly resistant to splitting. It is one of the strongest building materials available to Seabees. An odd number (3, 5, 7) of plies is used so that they will be balanced on either side of a center core and so that the grain of the outside layers runs in the same direction. The outer plies are called faces or face and back. The next layers under these are called crossbands, and the other inside layer or layers are called the core (figure 3-36). A plywood panel made of three layers would consist of two faces and a core.

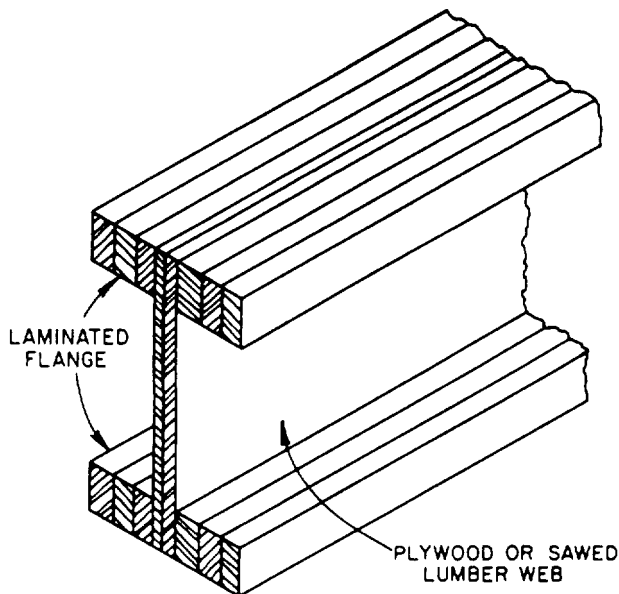

Figure 3-32.-Laminated and sawed lumber or plywood beam.

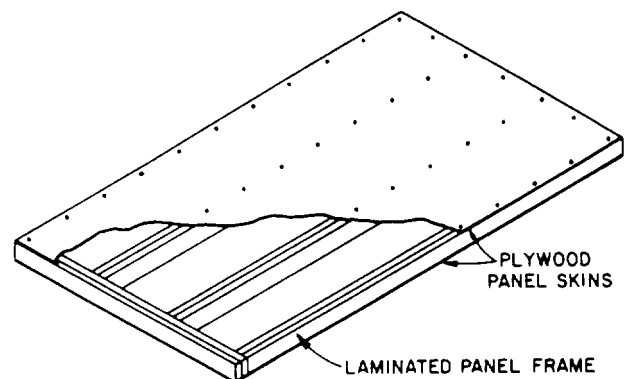

Figure 3-33.-Stressed skin panel.



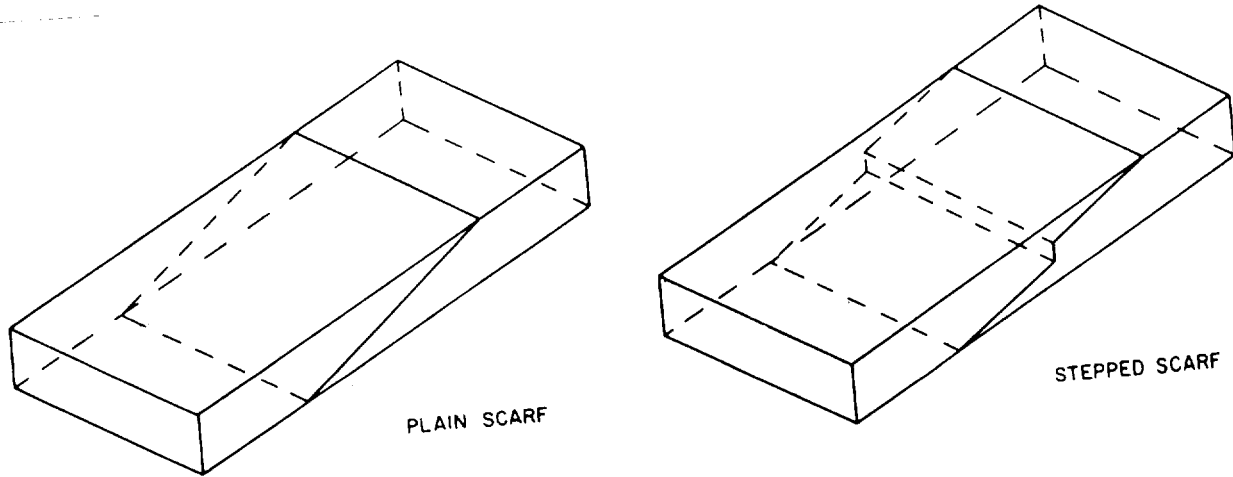

Figure 3-34.-Scarf joints.

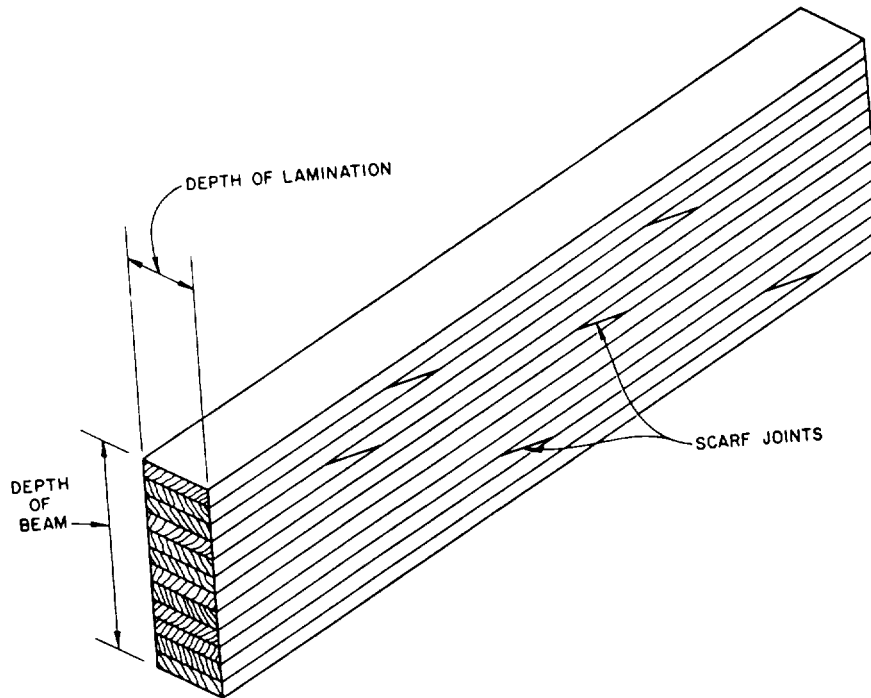

Figure 3-35.-Laminated beam.

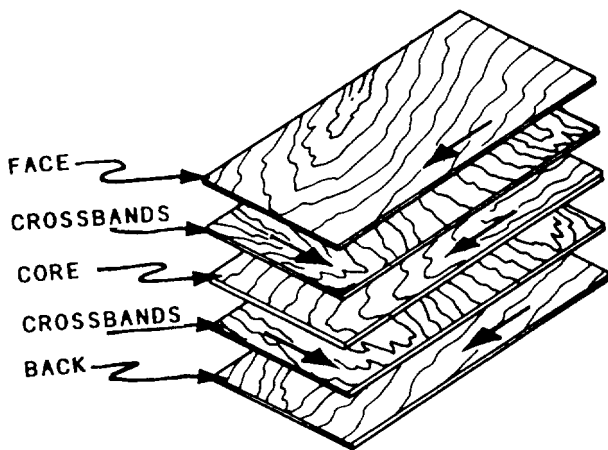

Figure 3-36.-Grain direction in a sheet of plywood.

There are two basic types of plywood: exterior and interior. Exterior plywood is bonded with waterproof glues. It can be used for siding, concrete forms, and other constructions where it will be exposed to the weather or excessive moisture. Interior plywood is bonded with glues that are not waterproof. It is used for cabinets and other inside construction where the moisture content of the panels will not exceed 20 percent.

Plywood is made in thicknesses of 1/8 inch to more than 1 inch, with the common sizes being 1/4, 3/8, 1/2, 5/8, and 3/4 inch. A standard panel size is 4-feet wide by 8-feet long. Smaller size panels are available in the hardwoods.

Table 3-7.-Plywood Veneer Grades

DESCRIPTION	
<b>N</b>	Special order "natural-finish" veneer. Select all heartwood or all sapwood. Free of open defects. Allows some repairs
<b>A</b>	Smooth and paintable. Neatly made repairs permissible. Also used for natural finish in less demanding applications
<b>B</b>	Solid surface veneer. Circular repair plugs and tight knots permitted
<b>C</b>	Knotholes to 1 inch. Occasional knotholes 1/2 inch larger permitted providing total width of all knots and knotholes within a specified section does not exceed certain limits. Limited splits permitted. Minimum veneer permitted in exterior-type plywood
<b>C Plgd</b>	Improved C veneer with splits limited to 1/8 inch in width and knotholes and borer holes limited to 1/4 inch by 1/2 inch
<b>D</b>	Permits knots and knotholes to 2 1/2 inches in width and 1/2 inch larger under certain specified limits. Limited splits permitted

Table 3-8.-Classification of Softwood Plywood Rates Species for Strength and Stiffness

GROUP 1	GROUP 2		GROUP 3	GROUP 4	GROUP 5
Apitong Beech, American Birch, Sweet Yellow Douglas fir Kapur Keruing Larch, Western Maple, Sugar Pine, Caribbean Ocote Pine, South Loblolly Longleaf Shortleaf Slash	Cedar, Port Orford Cypress Douglas fir Fir, California Red Grand Noble Pacific Silver Hemcock, White Western Lauan, Almon Bagtikan Mayapis Red lauan Tangile White lauan	Maple, Black Mengkulang Meranti, Red Mersawa Pine, Pond Red Virginia Western White Sruce, Red Sitka Sweetgum Tamarack Yellow poplar	Alder, Port Birch, Paper Cedar, Alaska Fir, Subalpine Hemlock, Eastern Maple, Bigleaf Pine, Jack Lodgepole Ponderosa Spruce Redwood Spruce, Black Engelmann White	Aspen, Bigtooth Quaking Cativo Cedar, Incense Western Red Cottonwood, Eastern Black Western popular Pine, Eastern White Sugar	Basswood Fir, Balsam Poplar, Balsam

Plywood can be worked quickly and easily with common carpentry tools. It holds nails well and normally does not split when nails are driven close to the edges. Finishing plywood presents no unusual problems; it can be sanded or texture coated with a permanent finish or left to weather naturally.

There is probably no other building material as versatile as plywood. It is used for concrete forms, wall and roof sheathing, flooring, box beams, soffits, stressed-skin panels, paneling, shelving, doors, furniture, cabinets, crates, signs, and many other items.

### Softwood Plywood Grades

All plywood panels are quality graded based on products standards (currently PS 1/74). The grade of each type of plywood is determined by the kind of veneer (N, A, B, C, or D) used for the face and back of the panel and by the type of glue used in construction. The plywood veneer grades are shown in table 3-7.

Many species of softwood are used in making plywood. There are five separate plywood groups based on stiffness and strength. Group 1 includes the stiffest and strongest; group 5 includes the weakest woods. A listing of groupings and associated woods is shown in table 3-8.

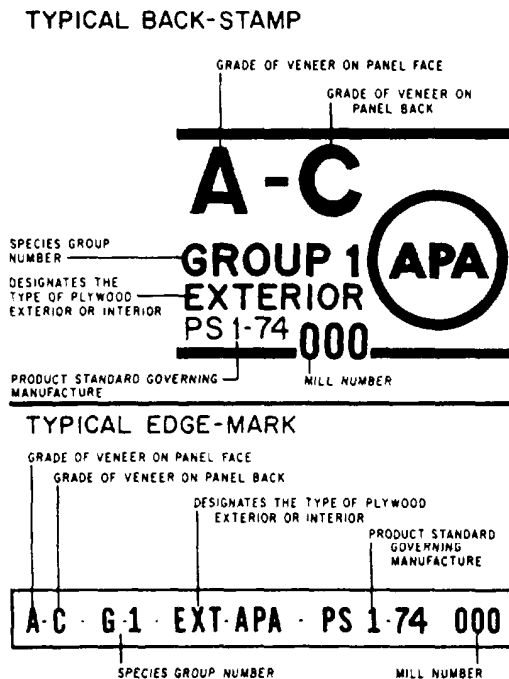

Figure 3-37.-Standard plywood identification symbols.

**GRADE/TRADEMARK STAMP.**— Construction and industrial plywood panels are marked with different stamps.

**Construction Panels.**— Grading identification stamps (such as those shown in figure 3-37) indicate the kind and type of plywood. The stamps are placed on the back and sometimes on the edges of each sheet of plywood.

For example, a sheet of plywood having the designation “A-C” would have A-grade veneer on the face and C-grade veneer on the back. Grading is also based on the number of defects, such as knotholes, pitch pockets, splits, discolorations, and patches in the face of each panel. Each panel or sheet of plywood has a stamp on the back that gives all the information you need. Table 3-9 lists some uses for construction-grade plywood.

**Industrial Panels.**— Structural and sheathing panels have a stamp found on the back. A typical example for an industrial panel grade of plywood is shown in figure 3-38.

The span rating shows a pair of numbers separated by a slash mark (/). The number on the left indicates the maximum recommended span in inches when the plywood is used as roof decking (sheathing). The right-hand number applies to span when the plywood is used as subflooring. The rating applies only when the sheet is placed the long dimension across three or more supports. Generally, the larger the span rating, the greater the stiffness of the panel.

Figure 3-39 lists some typical engineered grades of plywood. Included are descriptions and most common uses.

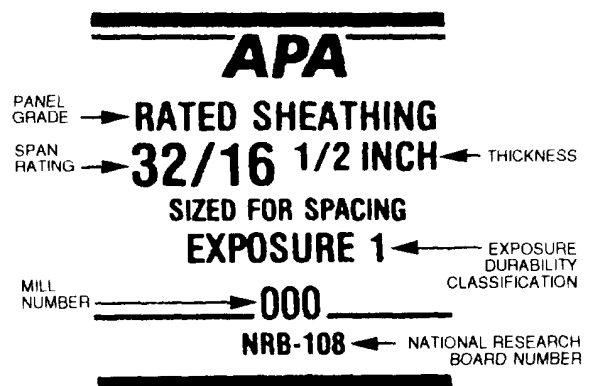

Figure 3-38.-Structural stamp.

Table 3-9.-Plywood Uses

<b>SOFTWOOD PLYWOOD GRADES FOR EXTERIOR USES</b>				
<b>Grade (Exterior)</b>	<b>Face</b>	<b>Back</b>	<b>Inner Plies</b>	<b>Uses</b>
A-A	A	A	C	Outdoor where appearance of both sides is important
A-B	A	B	C	Alternate for A-A where appearance of one side is less important
A-C	A	C	C	Siding, soffits, fences. Face is finish grade
B-C	B	C	C	For utility uses, such as farm buildings, some kinds of fences, etc.
C-C (Plugged)	C (Plugged)	C	C	Excellent base for tile and linoleum, backing for wall coverings
C-C	C	C	C	Unsanded, for backing and rough construction exposed to weather
B-B Concrete Forms	B	B	C	Concrete forms. Reuse until wood literally wears out
MDO	B	B or C	C or C-Plugged	Medium density overlay. Ideal base for paint; for siding, built-ins, signs, displays
HDO	A or B	A or B	C-Plugged	High density overlay. Hard surface; no paint needed. For concrete forms, cabinets, counter tops, tanks
<b>SOFTWOOD PLYWOOD GRADES FOR INTERIOR USES</b>				
<b>Grade (Interior)</b>	<b>Face</b>	<b>Back</b>	<b>Inner Plies</b>	<b>Uses</b>
A-A	A	A	D	Cabinet doors, built-ins, furniture where both sides will show
A-B	A	B	D	Alternate of A-A. Face is finish grade, back is solid and smooth
A-D	A	D	D	Finish grade face for paneling, built-ins, backing
B-D	B	D	D	Utility grade. One paintable side. For backing, cabinet sides, etc
Standard	C	D	D	Sheathing and structural uses such as temporary enclosures, subfloor. Unsanded

Typical Trademarks	Description and Common Uses	Grade Designation	EXTERIOR USE
<p><b>APA</b> RATED SHEATHING <b>48/24</b> 3/4 INCH SIZED FOR SPACING EXTERIOR 000 NRB-100</p>	<p>Exterior sheathing panel for subflooring and wall and roof sheathing, siding on service and farm buildings, crating, pallets, pallet bins, cable reels, etc. Manufactured as conventional veneered plywood. Common thicknesses: 5/16, 3/8, 1/2, 5/8, 3/4.</p>	<p><b>APA RATED SHEATHING EXT</b></p>	
<p><b>APA</b> RATED SHEATHING STRUCTURAL I <b>42/20</b> 5/8 INCH SIZED FOR SPACING EXTERIOR 000 PS 1-74 C.C. NRB-100</p>	<p>For engineered applications in construction and industry where resistance to permanent exposure to weather or moisture is required. Manufactured only as conventional veneered PS 1 plywood. Unsanded. STRUCTURAL I more commonly available. Common thicknesses: 5/16, 3/8, 1/2, 5/8, 3/4. (3)</p>	<p><b>APA STRUCTURAL I &amp; II RATED SHEATHING EXT</b></p>	
<p><b>APA</b> RATED STURD-I-FLOOR <b>20 OC</b> 19/32 INCH SIZED FOR SPACING EXTERIOR 000 NRB-100</p>	<p>For combination subfloor-underlayment under resilient floor coverings where severe moisture conditions may be present, as in balcony decks. Possesses high concentrated and impact load resistance. Manufactured only as conventional veneered plywood. Available square edge or tongue-and-groove. Common thicknesses: 5/8 (19/32), 3/4 (23/32).</p>	<p><b>APA RATED STURD-I-FLOOR EXT</b></p>	
<p><b>APA</b> RATED SHEATHING <b>32/16</b> 1/2 INCH SIZED FOR SPACING EXPOSURE 1 000 NRB-100</p>	<p>Specially designed for subflooring and wall and roof sheathing, but can also be used for a broad range of other construction and industrial applications. Can be manufactured as conventional veneered plywood, as a composite, or as a nonveneered panel. For special engineered applications, including high load requirements and certain industrial uses, veneered panels conforming to PS 1 may be required. Specify Exposure 1 when long construction delays are anticipated. Common thicknesses: 5/16, 3/8, 7/16, 1/2, 5/8, 3/4.</p>	<p><b>APA RATED SHEATHING EXP 1 or 2</b></p>	PROTECTED OR INTERIOR USE
<p><b>APA</b> RATED SHEATHING STRUCTURAL I <b>24/0</b> 3/8 INCH SIZED FOR SPACING EXPOSURE 1 000 PS 1-74 C.C. INT/EXT GLUE NRB-100</p>	<p>Unsanded all-veneer PS 1 plywood grades for use where strength properties are of maximum importance: structural diaphragms, box beams, gusset plates, stressed-skin panels, containers, pallet bins. Made only with exterior glue (Exposure 1). STRUCTURAL I more commonly available. Common thicknesses: 5/16, 3/8, 1/2, 5/8, 3/4. (3)</p>	<p><b>APA STRUCTURAL I &amp; II RATED SHEATHING EXP 1</b></p>	
<p><b>APA</b> RATED STURD-I-FLOOR <b>24 OC</b> 23/32 INCH SIZED FOR SPACING TAG NET WIDTH 47-1/2 EXPOSURE 1 000 NRB-100</p>	<p>For combination subfloor-underlayment. Provides smooth surface for application of resilient floor covering and possesses high concentrated and impact load resistance. Can be manufactured as conventional veneered plywood, as a composite, or as a nonveneered panel. Available square edge or tongue-and-groove. Specify Exposure 1 when long construction delays are anticipated. Common thicknesses: 5/8 (19/32), 3/4 (23/32).</p>	<p><b>APA RATED STURD-I-FLOOR EXP 1 or 2</b></p>	
<p><b>APA</b> RATED STURD-I-FLOOR <b>48 OC</b> 1-1/8 INCH (2-4-1) SIZED FOR SPACING EXPOSURE 1 TAG 000 INT/EXT GLUE NRB-100 FNA-UM-66</p>	<p>For combination subfloor-underlayment on 32- and 48-inch spans and for heavy timber roof construction. Provides smooth surface for application of resilient floor coverings and possesses high concentrated and impact load resistance. Manufactured only as conventional veneered plywood and only with exterior glue (Exposure 1). Available square edge or tongue-and-groove. Thickness: 1-1/8.</p>	<p><b>APA RATED STURD-I-FLOOR 48 oc (2-4-1) EXP 1</b></p>	
<p>(1) Specific grades, thicknesses, constructions and exposure durability classifications may be in limited supply in some areas. Check with your supplier before specifying.</p> <p>(2) Specify Performance-Rated Panels by thickness and Span Rating.</p> <p>(3) All plies in STRUCTURAL I panels are special improved grades and limited to Group 1 species. All plies in STRUCTURAL II panels are special improved grades and limited to Group 1, 2, or 3 species.</p>			

Figure 3-39.-List of engineered grade of softwood plywood.

**Exposure Ratings.**— The grade/trademark stamp lists the exposure durability classification for plywood. There are two basic types or ratings: exterior and interior. The exterior type has a 100-percent waterproof glue line, and the interior type has a highly moisture-resistant glue line. However, panels can be manufactured in three exposure durability classifications: Exterior, Exposure 1, and Exposure 2.

Panels marked "Exterior" can be used where there is continual exposure to weather and moisture. Panels marked "Exposure 1" can withstand moisture during extended periods, but they should be used only indoors. Panels marked "Exposure 2" can be used in protected locations. They may be subjected to some water leakage or high humidity but generally should be protected from weather.

Most plywood is made with waterproof exterior glue. However, interior panels may be made with intermediate or interior glue.

### Hardwood Plywood Grades

Hardwood plywood panels are primarily used for door skins, cabinets, and wall paneling. The Hardwood Plywood Manufacturers' Association has established a grading system with the following grades: premium (A), good grade (1), sound grade (2), utility grade (3), and backing grade (4). For example, an A-3 grade hardwood plywood would have a premium face and a utility back. A 1-1 grade would have a good face and a good back.

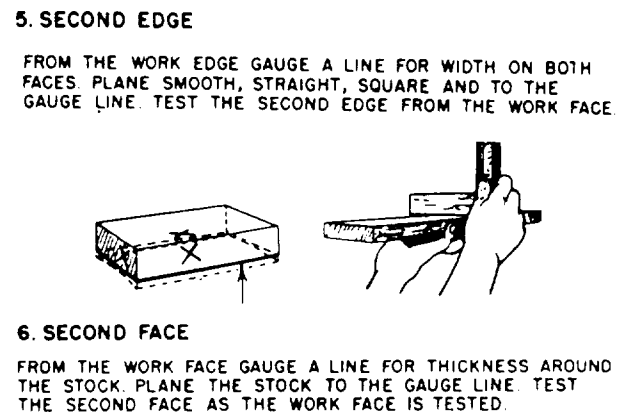
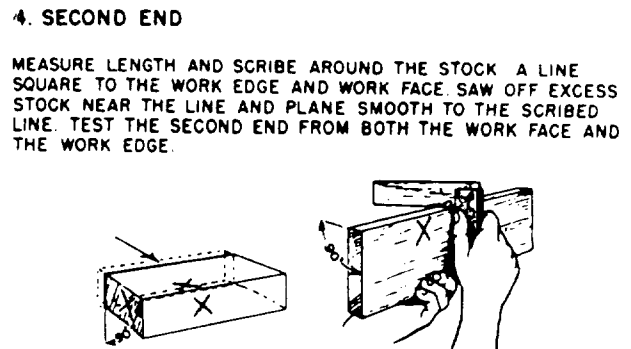
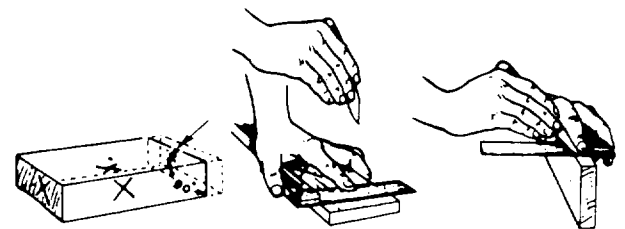
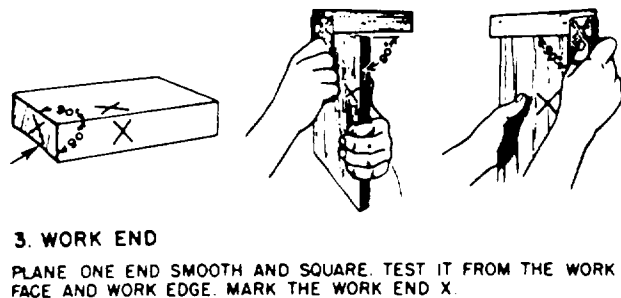
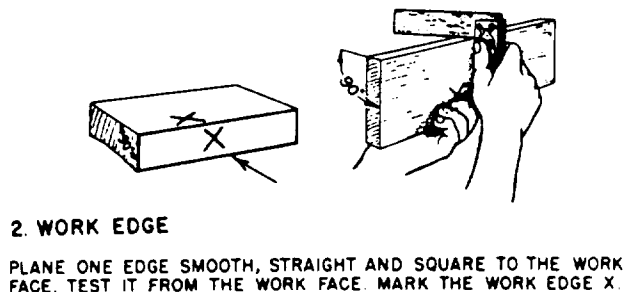
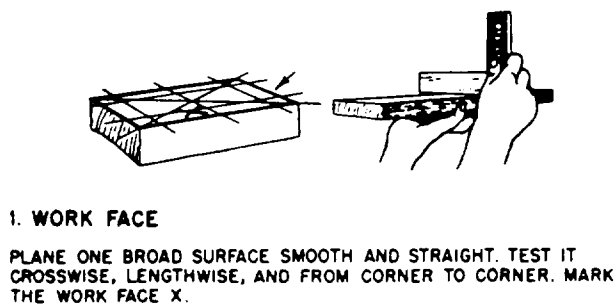

Figure 3-40.-Planing and squaring to dimensions.

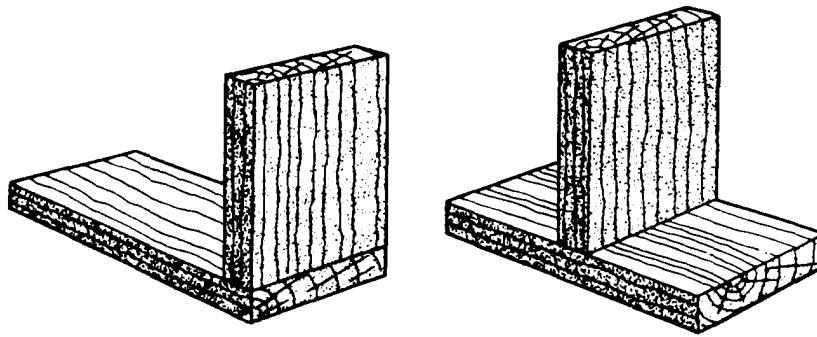

Figure 3-41.-90° plain butt Joints.

## WOODWORKING METHODS

*LEARNING OBJECTIVE: Upon completing this section, you should be able to identify the various methods and joints associated with woodworking.*

In the following section, we will cover some of the methods used by Builders in joining wood.

### PLANING AND SQUARING TO DIMENSIONS

Planing and squaring a small piece of board to dimensions is what you might call the first lesson in woodworking. Like many other things you may have tried to do, it looks easy until you try it. The six major steps in this process are illustrated and described in figure 3-40. You should practice these steps until you can get a smooth, square board with a minimum of planing.

### JOINTS AND JOINING

One basic skill of woodworking is the art of joining pieces of wood to form tight, strong, well-made joints. The two pieces that are to be joined together are called members. The two major steps in

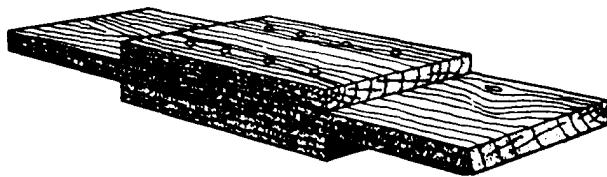

Figure 3-42.-End butt joints with fishplates.

making joints are (1) laying out the joint on the ends, edges, or faces and (2) cutting the members to the required shapes for joining.

The instruments normally used for laying out joints are the try square, miter square, combination square, the sliding T-bevel, the marking or mortising gauge, a scratch awl, and a sharp pencil or knife for scoring lines. For cutting the more complex joints by hand, the hacksaw dovetail saw and various chisels are essential. The rabbet-and-fillister plane (for rabbet joints) and the router plane (for smoothing the bottoms of dadoes and gains) are also helpful.

Simple joints, like the butt (figures 3-41 and 3-42), the lap (figure 3-43), and the miter joints

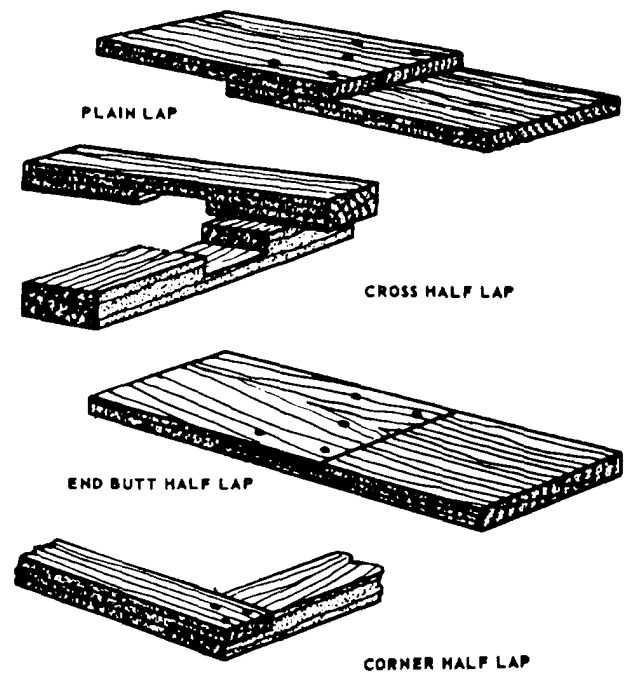

Figure 3-43.-Lap Joints.

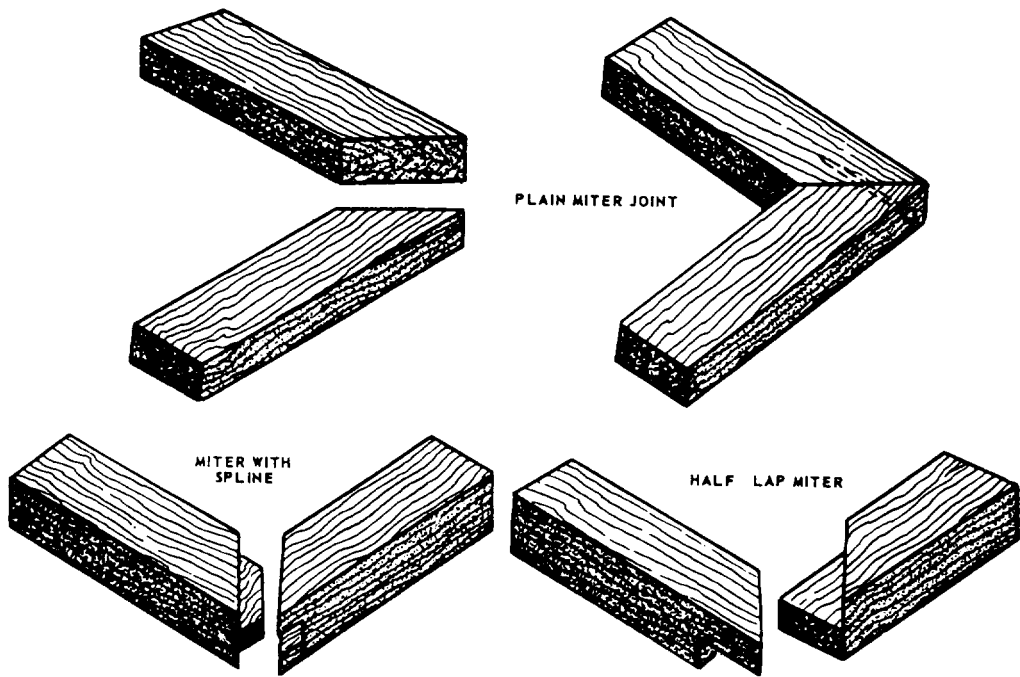

Figure 3-44.-Miter joints.

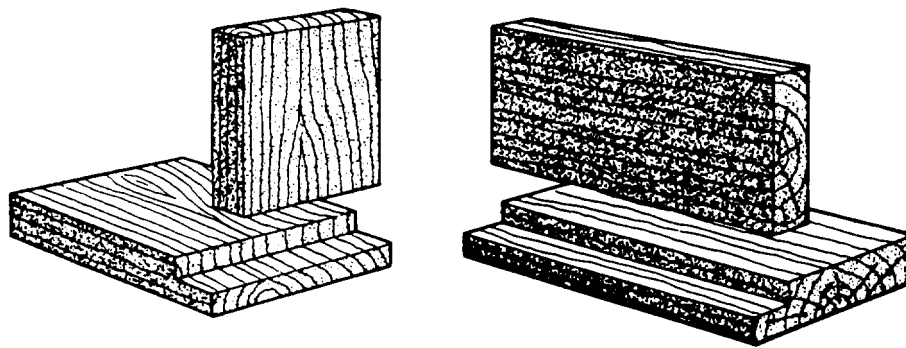

Figure 3-45.-Rabbet joints.

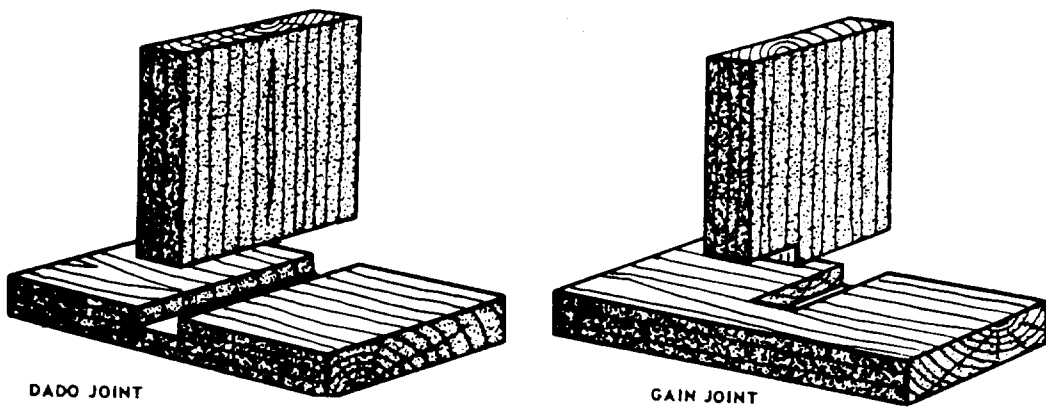

Figure 3-46.-Dado and gain joints.



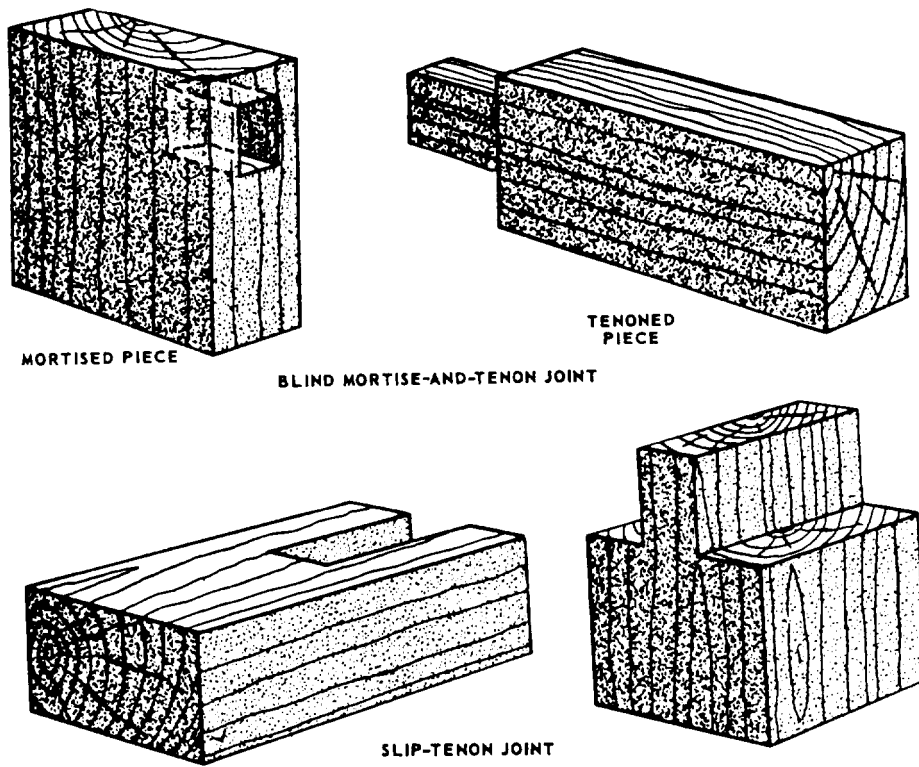

Figure 3-47.-Tenon joints.

(figure 3-44), are used mostly in rough or finish carpentry though they may be used occasionally in millwork and furniture making. More complex joints, like the rabbet joints (figure 3-45), the dado and gain joints (figure 3-46), the blind mortise-and-tenon and slip-tenon joints (figure 3-47), the box corner joint (figure 3-48), and the dovetail joints (figure 3-49), are used mostly in making furniture and cabinets and in

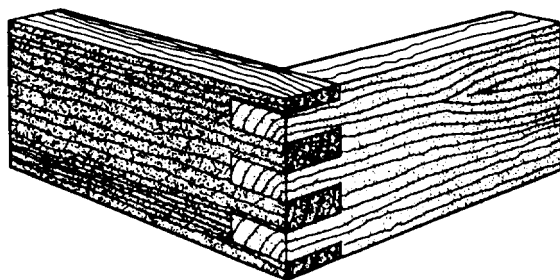

Figure 3-48.-BOX corner joint.

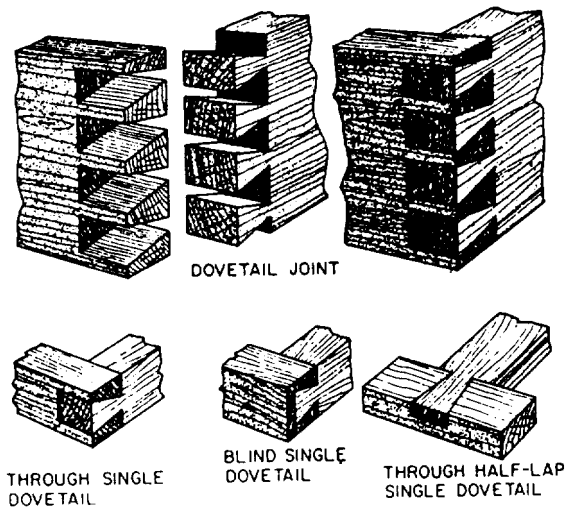

Figure 3-49.-Dovetail joints.

millwork. Of the edge joints shown in figure 3-50, the dowel and spline joints are used mainly in furniture and cabinet work, whereas the plain butt and the tongue-and-groove joints are used in practically all types of woodworking.

The joints used in rough and finished carpentry are, for the most part, simply nailed together. Nails in a 90° plain butt joint can be driven through the member abutted against and into the end of the abutting member. The joints can also be toenailed at an angle through the faces of the abutting member into the face of the member abutted against, as shown in figure 3-51. Studs and joists are usually toenailed to soleplates and sills.

The more complex furniture and cabinet-making joints are usually fastened with glue. Additional strength can be provided by dowels, splines, corrugated fasteners, keys, and other types of joint fasteners. In the dado joint, the gain joint, the mortise-and-tenon joint, the box corner joint, and the dovetail joint, the interlocking character of the joint is an additional factor in fastening.

All the joints we have been mentioned can be cut either by hand or by machine. Whatever the method used and whatever the type of joint, remember: To ensure a tight joint, always cut on the waste side of the line; never on the line itself. Preliminary grooving on the waste side of the line with a knife or chisel will help a backsaw start smoothly.

### Half-Lap Joints

For half-lap joints, the members to be jointed are usually of the same thickness, as shown in figure 3-43.

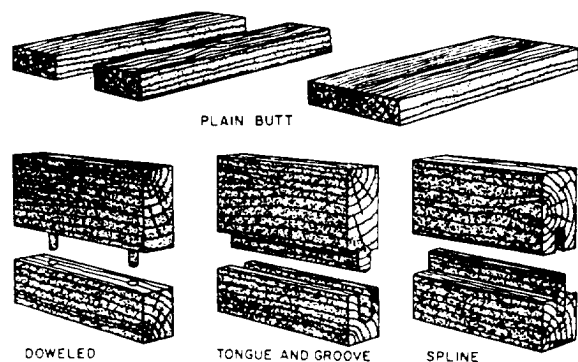

Figure 3-50.—Edge Joints.

The method of laying out and cutting an end butt half lap (figure 3-43) is to measure off the desired amount of lap from each end of each member and square a line all the way around at this point. For a corner half lap (figure 3-43), measure off the width of the member from the end of each member and square a line all the way around. These lines are called shoulder lines.

Next, select the best surface for the face and set a marking gauge to one-half the thickness and score a line (called the cheek line) on the edges and end of each member from the shoulder line on one edge to the shoulder line on the other edge. Be sure to gauge the cheek line from the face of each member. This ensures that the faces of each member will be flush after the joints are cut.

Next, make the shoulder cuts by cutting along the waste side of the shoulder lines down to the waste side of the cheek line. Then, make the cheek cuts along the waste side of the cheek lines. When all cuts have been made, the members should fit together with faces, ends, and edges flush or near enough to be made flush with the slight paring of a wood chisel.

Other half-lap joints are laid out in a similar manner. The main difference is in the method of cutting. A cross half-lap joint may best be cut with a dado head or wood chisel rather than a handsaw. Others may easily be cut on a bandsaw, being certain

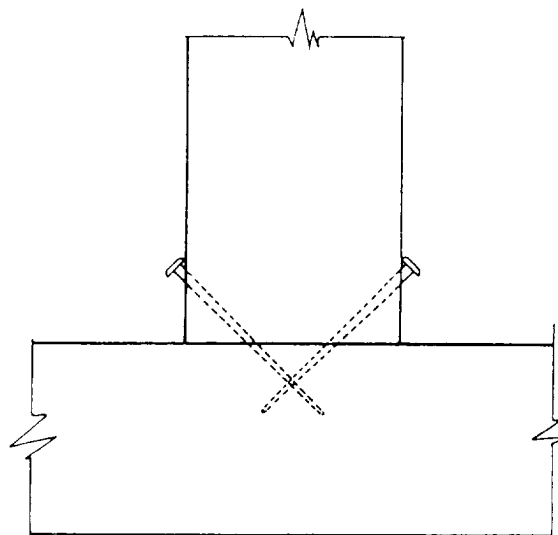

Figure 3-51.—Toenailing.

to cut on the waste side of the lines and making all lines from the face of the material.

### Miter Joints

A miter joint is made by mitering (cutting at an angle) the ends or edges of the members that are to be joined together (figure 3-44). The angle of the miter cut is one-half of the angle formed by the joined members. In rectangular mirror frames, windows, door casing boxes, and the like, adjacent members form a 90° angle, and, consequently, the correct angle for mitering is one-half of 90°, or 45°. For members forming an equal-sided figure with other than four sides (such as an octagon or a pentagon), the correct mitering angle can be found by dividing the number of sides the figure will have into 180° and subtracting the result from 90°. For an octagon (an eight-sided figure), determine the mitering angle by subtracting from 90° 180° divided by 8 or 90° minus 22.5° equals 67.5°. For a pentagon (a five-sided figure), the angle is

$$90^\circ - (180^\circ \div 5) \text{ or } 90^\circ - 36^\circ = 54^\circ$$

Members can be end mitered to 45° in the wooden miter box and to any angle in the steel miter box by setting the saw to the desired angle, or on the circular saw, by setting the miter gauge to the desired angle. Members can be edge mitered to any angle on the circular saw by tilting the saw to the required angle.

Sawed edges are sometimes unsuitable for gluing. However, if the joint is to be glued, the edges can be mitered on a jointer, as shown in figure 3-52.

### SAFETY NOTE

This is a dangerous operation and caution should be taken.

Since abutting surfaces of end-mitered members do not hold well when they are merely glued, they should be reinforced. One type of reinforcement is the corrugated fastener. This is a corrugated strip of metal with one edge sharpened for driving into the joint. The fastener is placed at a right angle to the line between the members, half on one member and half on the other, and driven down flush with the member. The corrugated fastener mars the appearance of the surface into which it is driven; therefore, it is used only on the backs of picture frames and the like.

A more satisfactory type of fastener for a joint between end-mitered members is the slip feather. This is a thin piece of wood or veneer that is glued

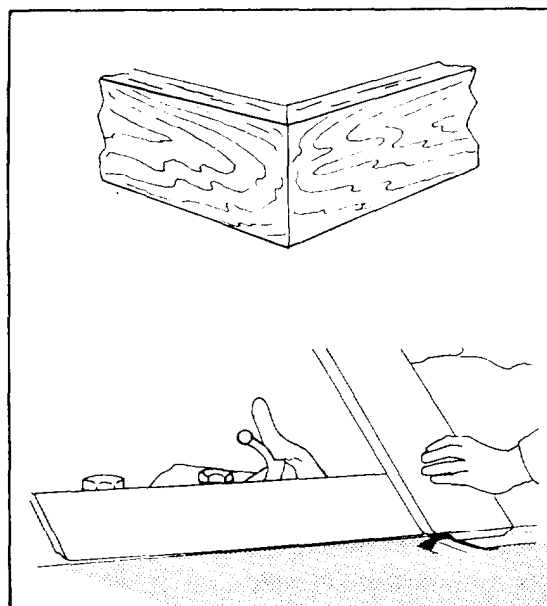

Figure 3-52.-Beveling on a jointer for a mitered edge joint.

into a kerf cut in the thickest dimension of the joint. First, saw about halfway through the wood from the outer to the inner corner, then apply glue to both sides of the slip feather, pushing the slip feather into the kerf. Clamp it tightly and allow the glue to dry. After it has dried, remove the clamp and chisel off the protruding portion of the slip feather.

A joint between edge-mitered members can also be reinforced with a spline. This is a thick piece of wood that extends across the joint into grooves cut in the abutting surfaces. A spline for a plain miter joint is shown in figure 3-44. The groove for a spline can be cut either by hand or by a circular saw.

### Grooved Joints

A three-sided recess running with the grain is called a groove, and a recess running across the grain is called a dado. A groove or dado that does not extend all the way across the wood is called a stopped groove or a stopped dado. A stopped dado is also known as a gain (figure 3-46). A two-sided recess running along an edge is called a rabbet T (figure 3-45). Dadoes, gains, and rabbets are not, strictly speaking, grooves; but joints that include them are generally called grooved joints.

A groove or dado can be cut with a circular saw as follows: Lay out the groove or dado on the end wood (for a groove) or edge wood (for a dado) that will first come in contact with the saw. Set the saw to the desired depth of the groove above the table, and set

the fence at a distance from the saw that will cause the first cut to run on the waste side of the line that indicates the left side of the groove. Start the saw and bring the wood into light contact with it; then stop the saw and examine the layout to ensure the cut will be on the waste side of the line. Readjust the fence, if necessary. When the position of the fence is right, make the cut. Then, reverse the wood and proceed to set and test as before for the cut on the opposite side of the groove. Make as many recuts as necessary to remove the waste stock between the side kerfs.

The procedure for grooving or dadoing with the dado head is about the same, except that, in many cases, the dado head can be built up to take out all the waste in a single cut. The two outside cutters alone will cut a groove 1/4 inch wide. Inside cutters vary in thickness from 1/16 to 1/4 inch.

A stopped groove or stopped dado can be cut on the circular saw, using either a saw blade or a dado head, as follows: If the groove or dado is stopped at only one end, clamp a stop block to the rear of the table in a position that will stop the wood from being fed any farther when the saw has reached the place where the groove or dado is supposed to stop. If the groove or dado is stopped at both ends, clamp a stop block to the rear of the table and a starting block to the front. The starting block should be placed so the saw will contact the place where the groove is supposed to start when the infeed end of the piece is against the block. Start the cut by holding the wood above the saw, with the infeed end against the starting block and the edge against the fence. Then, lower the wood gradually onto the saw, and feed it through to the stop block.

A rabbet can be cut on the circular saw as follows: The cut into the face of the wood is called the shoulder cut, and the cut into the edge or end, the cheek cut. To make the shoulder cut (which should be made first), set the saw to extend above the table a distance equal to the desired depth of the cheek. Be sure to measure this distance from a sawtooth set to the left, or away from the ripping fence. If you measure it from a tooth set to the right or toward the fence, the cheek will be too deep by an amount equal to the width of the saw kerf.

By using the dado head, you can cut most ordinary rabbets in a single cut. First, build up a dado head equal in thickness to the desired width of the cheek. Next, set the head to protrude above the table a distance equal to the desired depth of the should. Clamp a 1-inch board to the fence to serve as a guide for the piece, and set the fence so the edge of the

board barely contacts the right side of the dado head. Set the piece against the miter gauge (set at 90°), hold the edge or end to be rabbeted against the 1-inch board, and make the cut.

On some jointers, a rabbeting ledge attached to the outer edge of the infeed table can be depressed for rabbeting, as shown in figure 3-53. The ledge is located on the outer end of the butterhead. To rabbet on a jointer of this type, you depress the infeed table and the rabbeting ledge the depth of the rabbet below the outfeed table, and set the fence the width of the rabbet away from the outer end of the butterhead. When the piece is fed through, the unrabbeted part feeds onto the rabbeting ledge. The rabbeted portion feeds onto the outfeed table.

Various combinations of the grooved joints are used in woodworking. The tongue-and-groove joint is a combination of the groove and the rabbet, with the tongued member rabbeted on both faces. In some types of paneling, the tongue is made by rabbeting only one face. A tongue of this kind is called a barefaced tongue. A joint often used in making boxes, drawers, and cabinets is the dado and rabbet joint, shown in figure 3-54. As you can see, one of the members is rabbeted on one face to form a barefaced tongue.

### Mortise-and-Tenon Joints

The mortise-and-tenon joint is most frequently used in furniture and cabinet work. In the blind mortise-and-tenon joint, the tenon does not penetrate

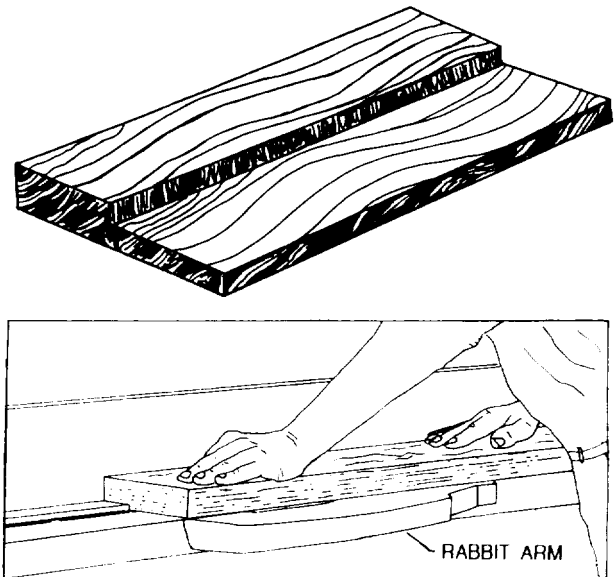
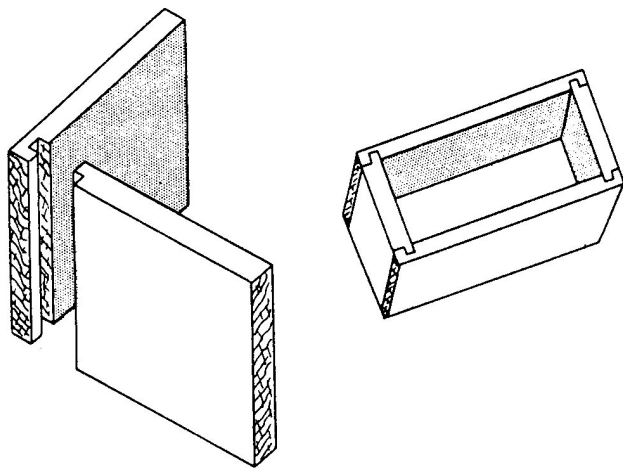
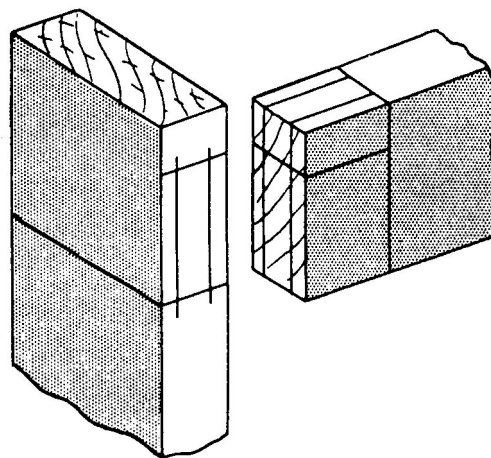

Figure 3-53.-Rabbeting on a jointer with a rabbeting ledge.



**Figure 3-54.-Dado and rabbet joint.**

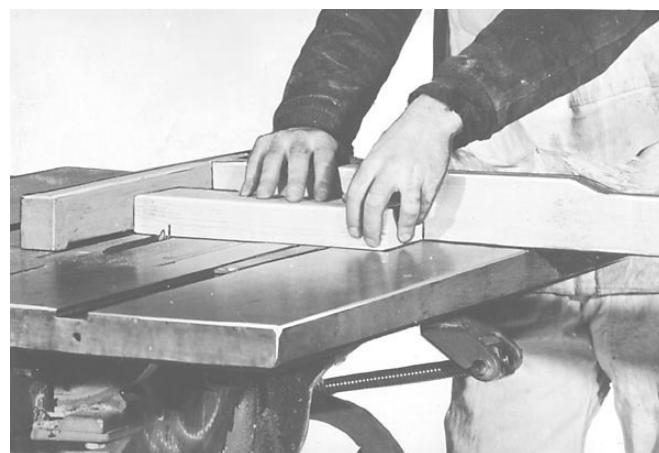

**Figure 3-56.-Layout of stub mortise-and-tenon joint.**

all the way through the mortised member (figure 3-47).

A joint in which the tenon does penetrate all the way through is a through mortise-and-tenon joint (figure 3-55). Besides the ordinary stub joint (view A), there are haunched joints (view B) and table-haunched joints (view C). Haunching and table-haunching increase the strength and rigidity of the joint.

The layout procedure for an ordinary stub mortise-and-tenon joint is shown in figure 3-56. The shoulder and cheek cuts of the tenon are shown in figures 3-57 and 3-58. To maintain the stock upright while making the cheek cuts, use a push board similar to the one shown in figure 3-58. Tenons can also be cut with a dado head by the same method previously described for cutting end half-lap joints.



103.22

**Figure 3-57.-Making tenon shoulder cut on a table saw.**

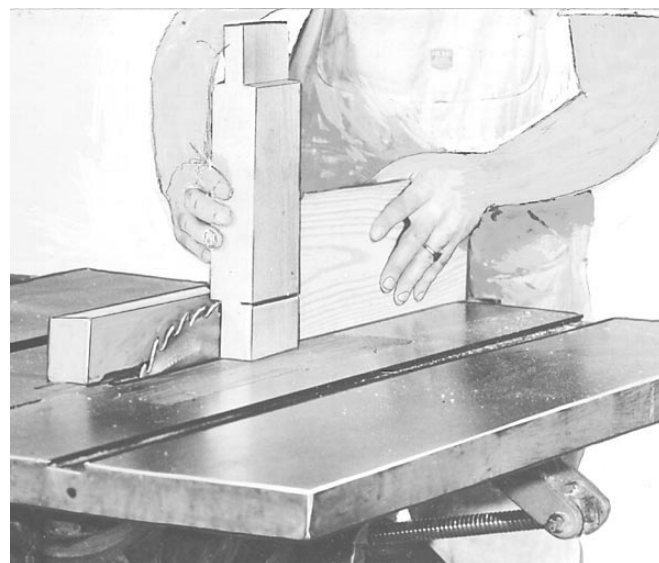

103.23

**Figure 3-58.-Making tenon cheek cut on a table saw using a push board.**

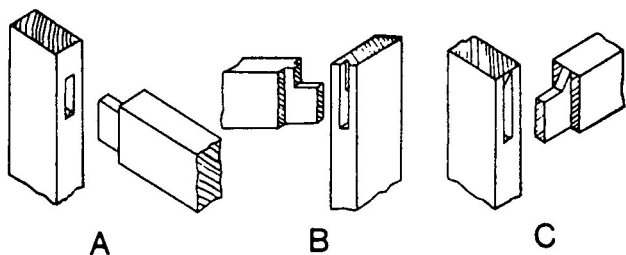

**Figure 3-55.-Stub (view A), haunched (view B), and table-haunched (view C) mortise-and-tenon joints.**

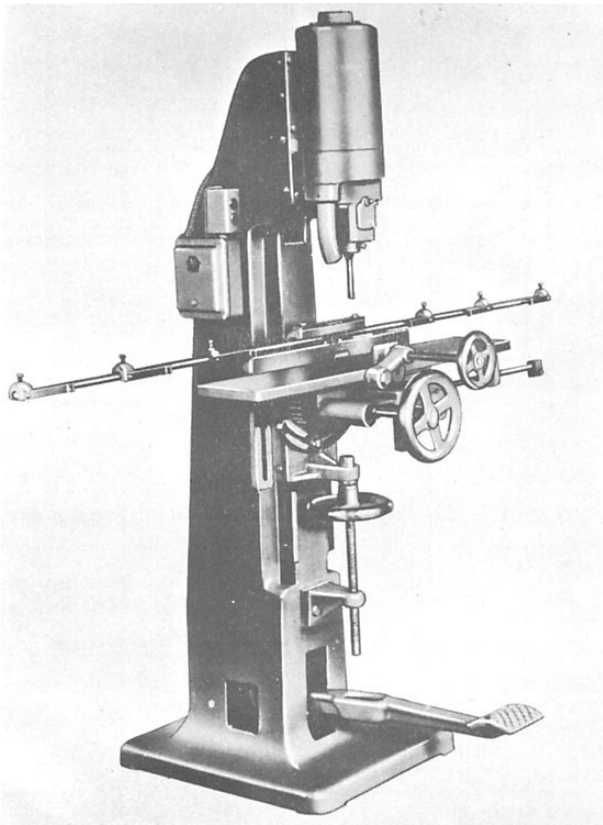

103.24

**Figure 3-59.-Hollow-chisel mortising machine.**

Mortises are cut mechanically on a hollow-chisel mortising machine like the one shown in figure 3-59. The cutting mechanism on this machine consists of a boring bit encased in a square, hollow, steel chisel. As the mechanism is pressed into the wood, the bit takes out most of the waste while the chisel pares the sides of the mortise square. Chisels come in various sizes, with corresponding sizes of bits to match. If a mortising machine is not available, the same results can be attained by using a simple drill press to take out most of the waste and a hand chisel, for paring the sides square.

In some mortise-and-tenon joints, such as those between rails and legs in tables, the tenon member is much thinner than the mortise member. Sometimes a member of this kind is too thin to shape in the customary reamer, with shoulder cuts on both faces. When this is the case, a barefaced mortise-and-tenon joint can be used. In a barefaced joint, the tenon member is shoulder cut on one side only. The cheek on the opposite side is simply a continuation of the face of the member.

Mortise-and-tenon joints are fastened with glue and with additional fasteners, as required.

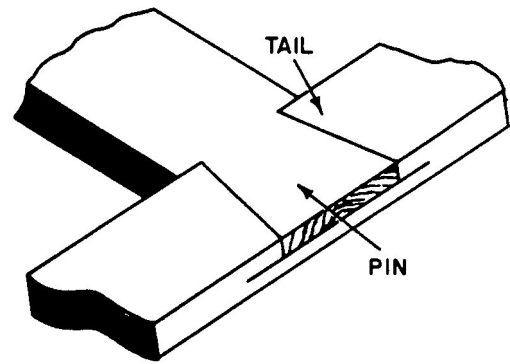

**Figure 3-60.-Dovetail half-lap Joint.**

### Dovetail Joints

The dovetail joint (figure 3-49) is the strongest of all the woodworking joints. It is used principally for joining the sides and ends of drawers in fine grades of furniture and cabinets. In the Seabee units, you will seldom use dovetail joints since they are laborious and time-consuming to make.

A through dovetail joint is a joint in which the pins pass all the way through the tail member. Where the pins pass only part way through, the member is known as a blind dovetail joint.

The simplest of the dovetail joints is the dovetail half-lap joint, shown in figure 3-60. Figure 3-61 shows how this type of joint is laid out, and figure 3-62 shows the completed joint.

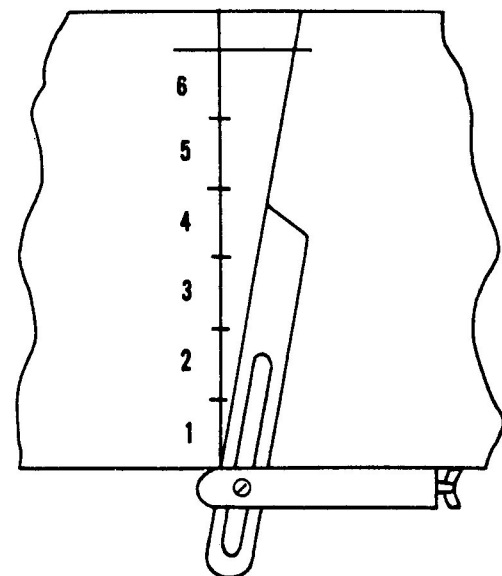

**Figure 3-61.-Laying off 10° angle for dovetail joint.**

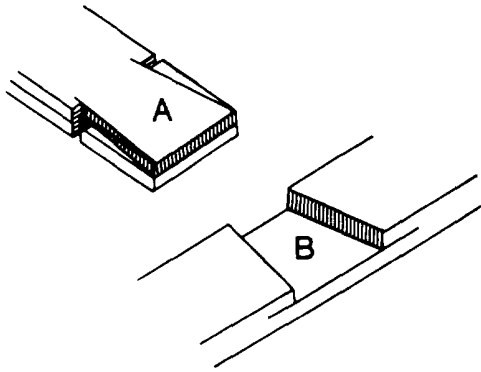

Figure 3-62.-Making a dovetail half-lap joint.

A multiple dovetail joint is shown in figure 3-63; figure 3-64 indicates how the waste is chiseled from the multiple joint.

### Box Corner Joints

With the exception of the obvious difference in the layout, the box corner joint (figure 3-48) is made in a similar manner as the through-multiple-dovetail joint.

### Coping Joints

Inside corner joints between molding trim members are usually made by butting the end of one member against the face of the other. Figure 3-65

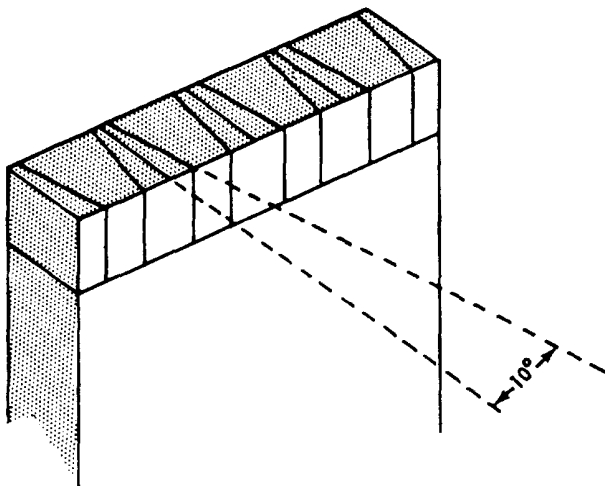

Figure 3-63.-Laying out a pin member for a through-multiple-dovetail joint.

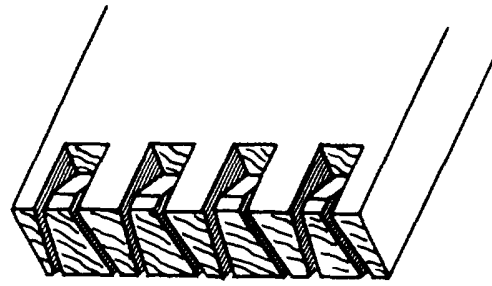

Figure 3-64.-Chiseling out waste in a through-multiple-dovetail joint.

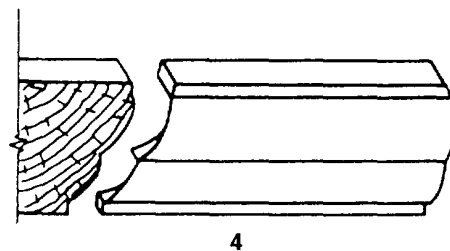
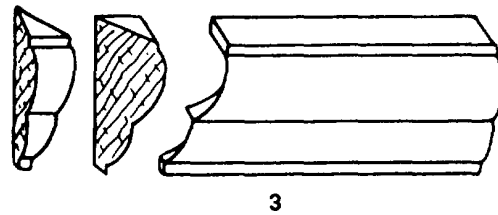
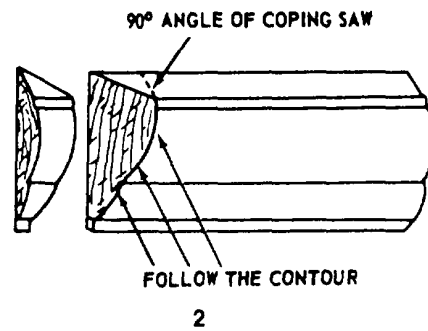
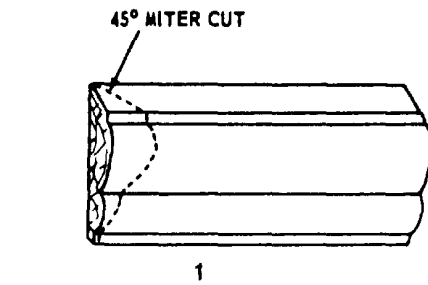

Figure 3-65.-Making a coping Joint.

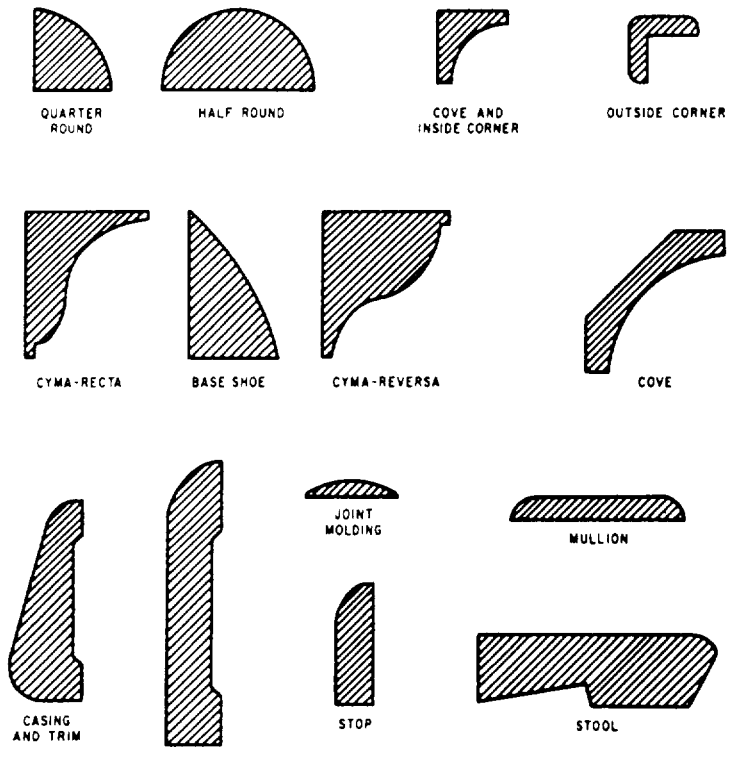

Figure 3-66.-Simple molding and trim shapes.

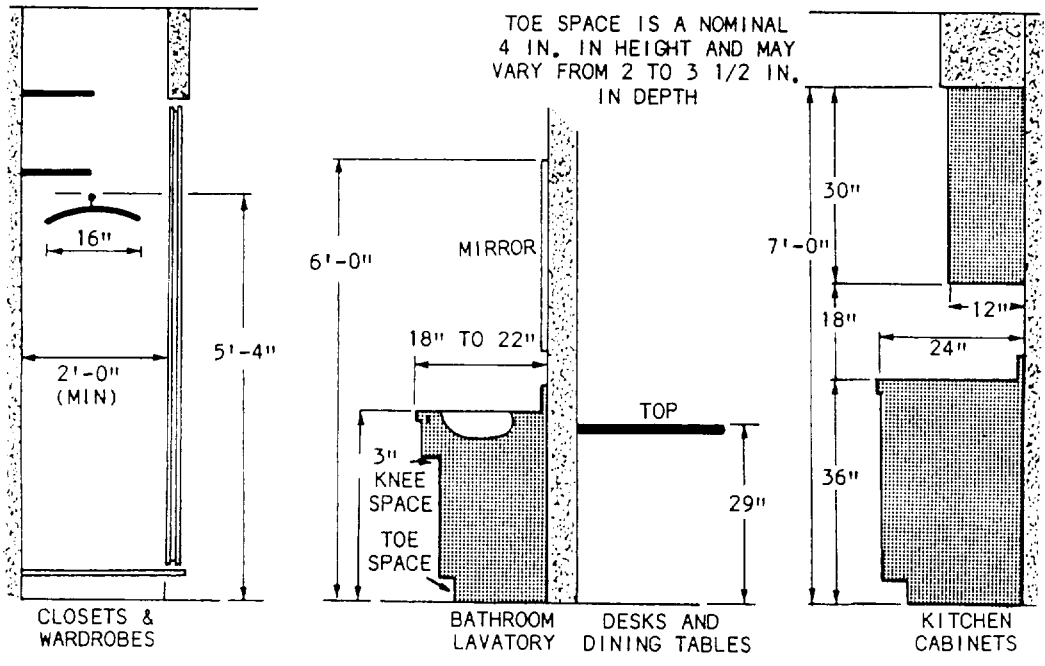

Figure 3-67.-Typical dimensions for cabinetwork.



shows the method of shaping the end of the abutting member to fit the face of the other member. First, saw off the end of the abutting member square, as you would for an ordinary butt joint between ordinary flat-faced members. Then, miter the end to 45°, as shown in the first and second views of figure 3-65. Set the coping saw at the top of the line of the miter cut, hold the saw at 90° to the lengthwise axis of the piece, and saw off the segment shown in the third view, following closely the face line left by the 45° miter cut. The end of the abutting member will then match the face of the other member, as shown in the third view. A joint made in this manner is called a coping joint. You will have to cut coping joints on a large variety of moldings. Figure 3-66 shows the simplest and most common moldings and trims used in woodworking.

## MILLWORK

*LEARNING OBJECTIVE: Upon completing this section, you should be able to recognize the various types of millwork products and procedures.*

As a general term, millwork usually embraces most wood products and components that require manufacturing. It not only includes the interior trim and doors, but also kitchen cabinets and similar units. Most of these units are produced in a millwork manufacturing plant and are ready to install. Figure 3-67 is an example of the dimensions you might be working with.

## BUILDING CABINETS IN PLACE

One of the most common ways of building cabinets, such as those shown in figure 3-68, is to cut

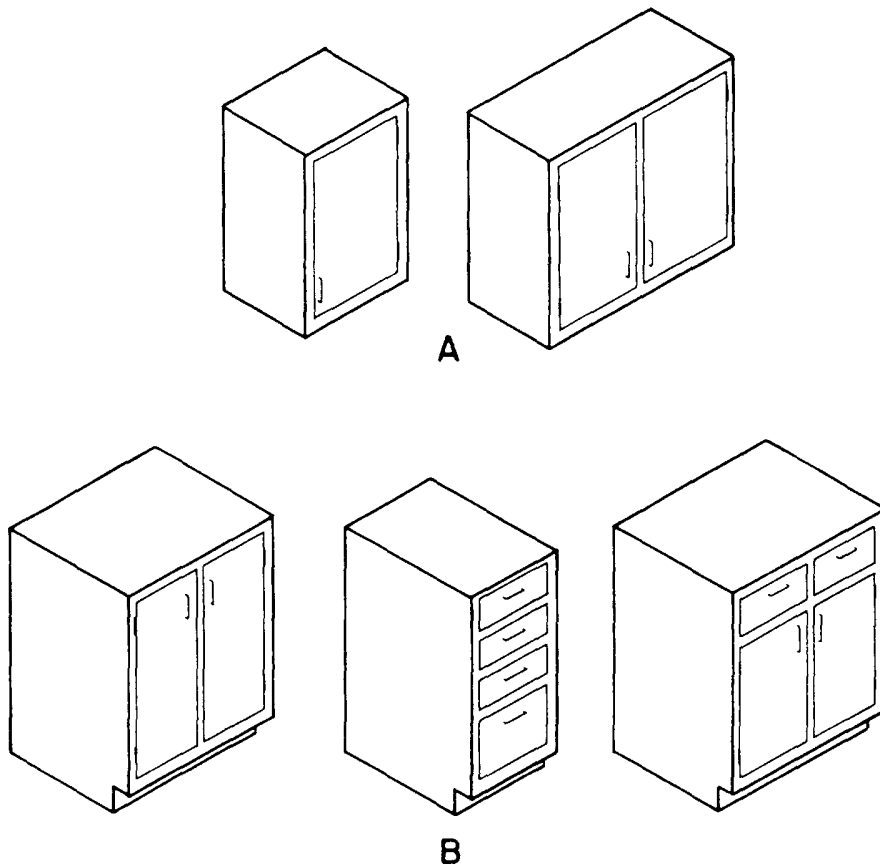

Figure 3-68.-Typical kitchen cabinets: wall (view A) and base (view B).

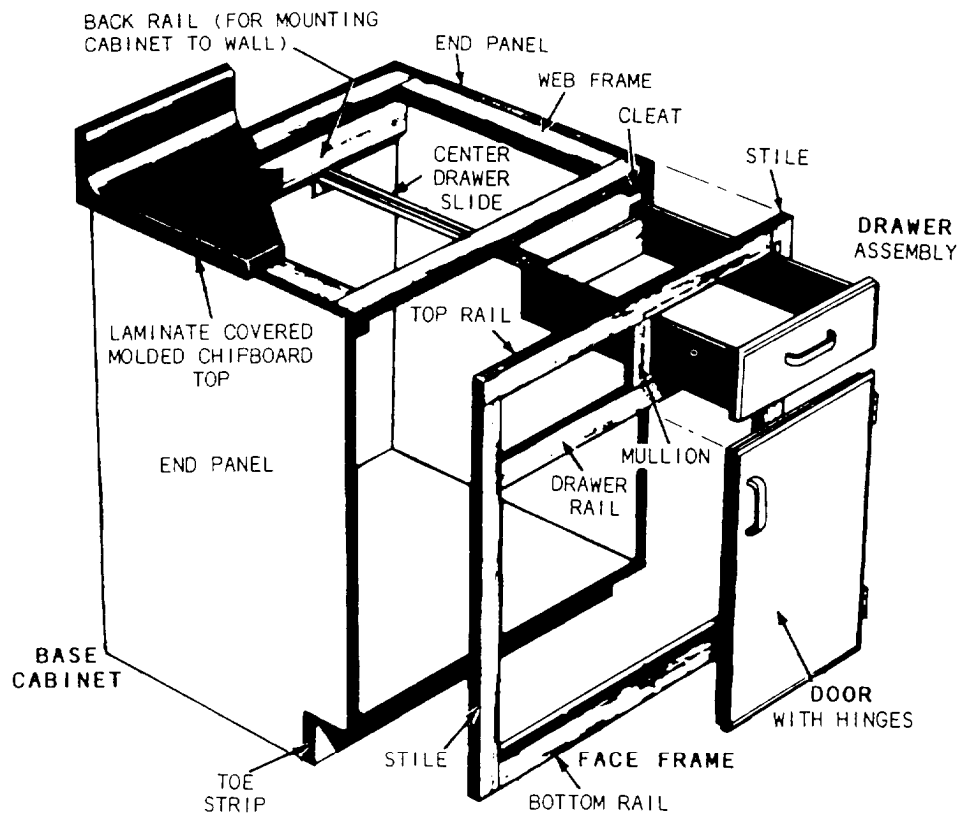

Figure 3-69.-Typical frame construction of a cabinet.

the pieces (figure 3-69) and assemble them in place. Think of building in-place cabinets in four steps.

1. Construct the base first. Use straight 2-by-4 lumber for the base. Nail the lumber to the floor and to a strip attached to the wall. If the floor is not level, place shims under the various members of the base. Later, you can face any exposed 2-by-4 surfaces with a finished material, or the front edge can be made of a finished piece, such as base molding.

2. Next, cut and install the end panels. Attach a strip along the wall between the end panels and level with the top edge. Be sure the strip is level throughout its length. Nail it securely to the wall studs.

3. Cut the bottom panels and nail them in place on the base. Follow this with the installation of the partitions, which are notched at the back corner of the top edge so they will fit over the wall strip.

4. Finally, plumb the front edge of the partitions and end panels. Secure them with temporary strips nailed along the top.

Wall units are made using the same basic steps as the base units. You should make your layout lines directly on the ceiling and wall. Nail the mounting

strips through the wall into the studs. At the inside corners, end panels can be attached directly to the wall.

Remember to make your measurements for both base and wall units carefully, especially for openings for built-in appliances. Refer frequently to your drawings and specifications to ensure accuracy.

### Shelves

Shelves are an integral part of cabinetmaking, especially for wall units. Cutting dados into cabinet walls to fit in shelves may actually strengthen the cabinet (figure 3-70.) When adding shelves, try to make them adjustable so the storage space can be altered as needed. Figure 3-71 shows two methods of installing adjustable shelves.

Whatever method of shelf support you use, make sure that your measurements are accurate and the shelves are level. Most of the time, you will find it easier to do your cutting and drilling before you start assembling the cabinets. If the shelf standards are the type that are set in a groove, you must cut the groove

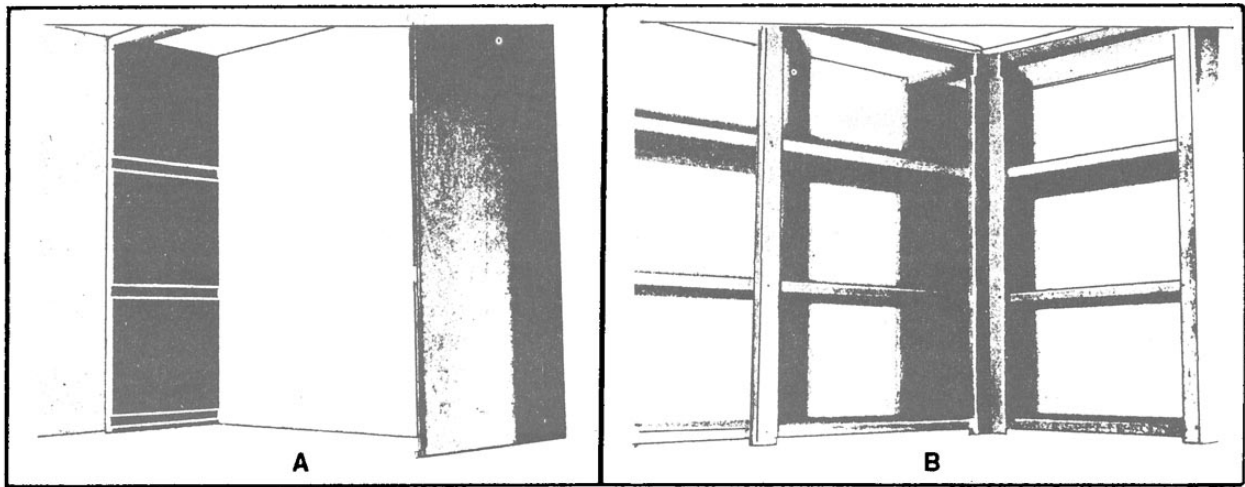

**Figure 3-70.-End panels of a wall cabinet in place (view A) and completed framing with facing partially applied (view B).**

before assembly. Some adjustable shelf supports can be mounted on the surface.

Shelving supports for 3/4-inch shelves should be placed no more than 42-inches apart. Shelves designed to hold heavy loads should have closer supports. To improve the appearance of plywood shelving, cover the laminated edge with a strip of wood that matches the stock used for the cabinet.

### Cabinet Facing

After completing the frame construction and shelving, apply finished facing strips to the front of the cabinet frame. These strips are sometimes assembled into a framework (called a faceplate or face frame) by commercial sources before they are

attached to the basic cabinet structure. The vertical members of the facing are called stiles, and the horizontal members are known as rails.

As previously mentioned for built-in-place cabinets, you cut each piece and install it separately. The size of each piece is laid out by positioning the facing stock on the cabinet and marking it. Then, the finished cuts are made. A cut piece can be used to lay out duplicate pieces.

Cabinet stiles are generally attached first, then the rails (figure 3-72). Sometimes a Builder will attach a

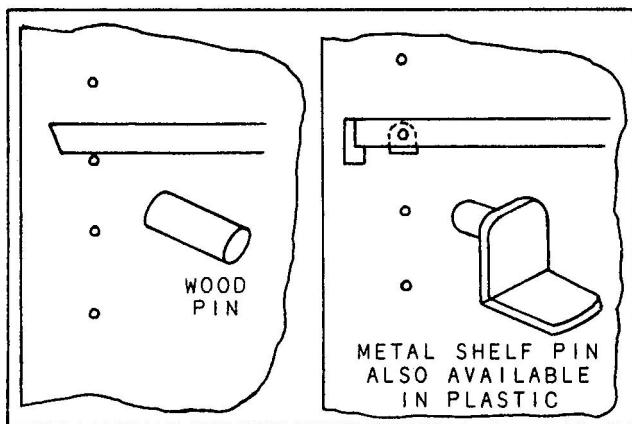

**Figure 3-71.-Two methods of supporting shelves.**

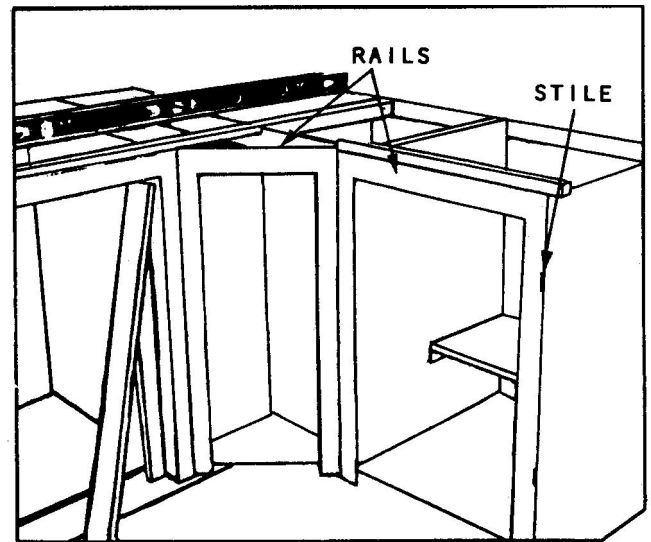

**Figure 3-72.-Facing being placed on a cabinet.**

plumb end stile first, and then attach rails to determine the position of the next stile.

Use finishing nails and glue to install facing. When nailing hardwoods, drill nail holes where you think splitting might occur.

## Drawers

Seabees use many methods of building drawers. The three most common are the multiple dovetail, lock-shouldered, and square-shouldered methods (figure 3-73).

There are several types of drawer guides available. The three most commonly used are the side guide, the corner guide, and the center guide (shown in figure 3-74, view A).

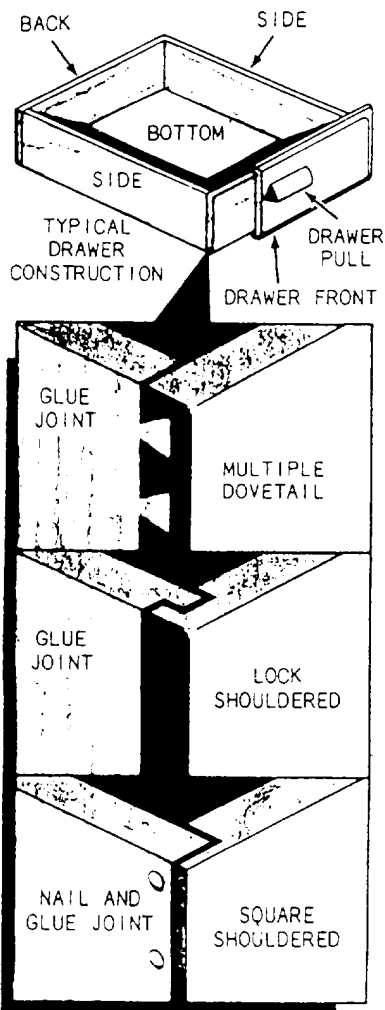

Figure 3-73.-Three common types of joints used in drawer construction.

The two general types of drawer faces are the lip and flush faces (shown in figure 3-74, view B). A flush drawer must be carefully fitted. A lip drawer must have a rabbet along the top and sides of the front. The lip style overlaps the opening and is much easier to construct.

## Cabinet Doors

The four types of doors commonly used on cabinets are the flush, lipped, overlay, and sliding doors. A flush door, like the flush drawer, is the most difficult to construct. For a finished look, each type of door must be fitted in the cabinet opening within 1/16-inch clearance around all four edges. A lipped door is simpler to install than a flush door since the lip, or overlap, feature allows you a certain amount of adjustment and greater tolerances. The lip is formed by cutting a rabbet along the edge.

Overlay doors are designed to cover the edges of the face frame. There are several types of sliding doors used on cabinets. One type of sliding door is rabbeted to fit into grooves at the top and bottom of the cabinet. The top groove is always made to allow the door to be removed by lifting it up and pulling the bottom out.

## INSTALLING PREMADE CABINETS

To install premade cabinets, you can begin with either the wall or base cabinets. The general procedures for each are similar.

### Installing the Wall Cabinets First

When layouts are made and wall studs located, the wall units are lifted into position. They are held with a padded T-brace that allows the worker to stand close to the wall while making the installation. After the wall cabinets are securely attached and checked, the base cabinets are moved into place, leveled, and secured.

### Installing the Base Cabinets First

When base cabinets are installed first, the tops of the base cabinets can be used to support braces that hold the wall units in place while they are fastened to the wall.

## Procedures

The following procedures are a simple way of installing premade cabinets:

1. First, locate and mark the location of all wall studs where the cabinets are to be hung. Find and mark the highest point in the floor. This will ensure the base cabinet is level on uneven floor surfaces. (Shims should be used to maintain the cabinet at its designated leveled height.)

2. Start the installation of a base cabinet with a corner or end unit. After all base cabinets are in position, fasten the cabinets together. To get maximum holding power from screws, place one hole close to the top and one close to the bottom.

3. Starting at the highest point in the floor, level the leading edges of the cabinets. After leveling all the leading edges, fasten them to the wall at the studs to obtain maximum holding power.

4. Next, install the countertop on the base cabinets making sure to drill or screw through the top.

5. Then, make a brace to help support the wall cabinets while they are being fastened. Start the wall cabinet installation with a corner or end cabinet. Make sure you check for plumb and level as you install these cabinets.

6. After installing the cabinets and checking for plumb and level, join the wall cabinets through the sides as you did with the base cabinets.

7. Finally, after they are plumb and level, secure the cabinets to the wall at the studs for maximum holding power.

Here are some helpful hints for the general construction of cabinets:

- Cabinet parts are fastened together with screws or nails. They are set below the surface, and the holes are filled with putty. Glue is used at all joints. Clamps should be used to produce better fitting, glued joints.
- A better quality cabinet is rabbeted where the top, bottom, back, and side pieces come together. However, butt joints are also used. If panels are less than 3/4-inch thick, a reinforcing block should be used with the butt joint. Fixed shelves are dadoed into the sides.
- Screws should go through the hanging strips and into the stud framing. Never use nails. Toggle bolts are required when studs are inaccessible. Join units by first clamping them together and then, while aligned, install bolts and T-nuts.

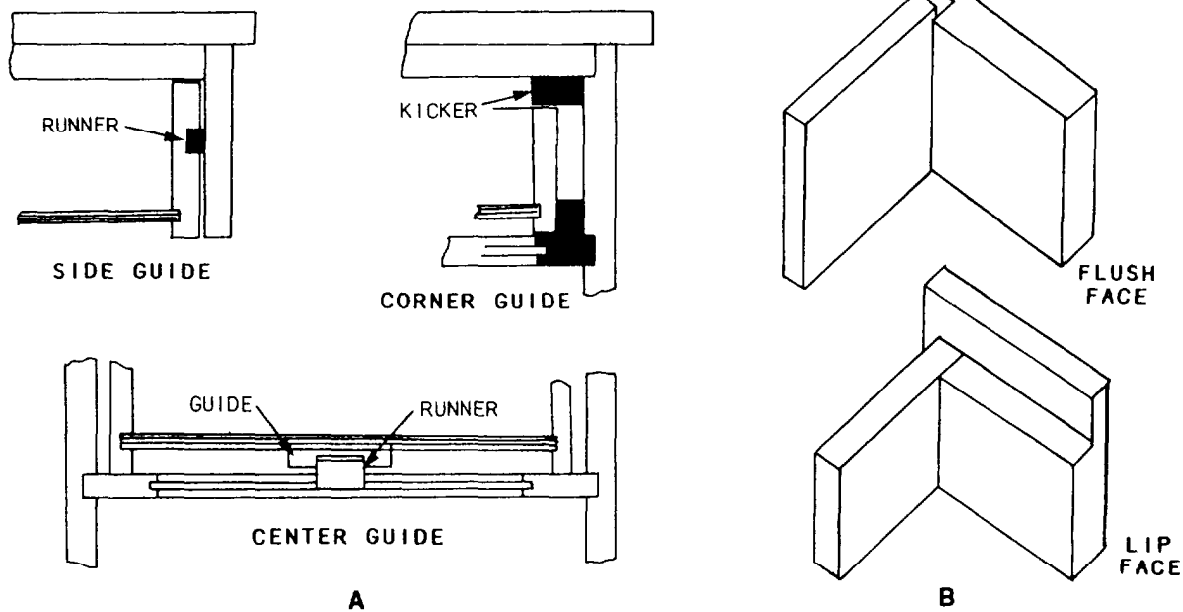

Figure 3-74.-Types of drawer guides (view A) and faces (view B).

## COUNTERS AND TOPS

In cabinetwork, the counters and tops are covered with a 1/16-inch layer of high-pressure plastic laminate. Although this material is very hard, it does not possess great strength and is serviceable only when it is bonded to plywood, particle board, or wafer wood. This base, or core material, must be smooth and is usually 3/4-inch thick.

### Working Laminates

Plastic laminates can be cut to rough size with a table saw, portable saw, or saber saw. Use a fine-tooth blade, and support the material close to the cut. If no electrical power is available, you can use a finish handsaw or a hacksaw. When cutting laminates with a saw, place masking tape over the cutting area to help prevent chipping the laminate. Make cut markings on the masking tape.

Measure and cut a piece of laminate to the desired size. Allow at least 1/4-inch extra to project past the edge of the countertop surface. Next, mix and apply the contact bond cement to the underside of the laminate and to the topside of the countertop surface. **Be sure to follow the manufacturer's recommended directions for application.**

### Adhering Laminates

Allow the contact bond cement to set or dry. To check for bonding, press a piece of waxed brown paper on the cement-coated surface. When no adhesive residue shows, it is ready to be bonded. Be sure to lay a full sheet of waxed brown paper across the countertop. This allows you to adjust the laminate into the desired position without permanent bonding. Now, you can gradually slide the paper out from under the laminate, and the laminate becomes bonded to the countertop surface.

Be sure to roll the laminate flat by hand, removing any air bubbles and getting a good firm bond. After sealing the laminate to the countertop surface, trim the edges by using either a router with a special guide or a small block plane. If you want to bevel the countertop edge, use a mill file.

## METHODS OF FASTENING

*LEARNING OBJECTIVE: Upon completing this section, you should be able to identify the different types of fastening devices.*

A variety of metal fastening devices are used by Seabees in construction. Although nails are the most commonly used fastener, the use of staples to attach wood structural members is growing. For certain operations, screws and bolts are required. In addition, various metal devices exist for anchoring materials into concrete, masonry, and steel.

The increasing use of adhesives (glues and mastics) is an important development in the building industry. Adhesives are used in combination with, or in place of, nails and screws.

### NAILS

Nails, the most common type of metal fasteners, are available in a wide range of types and sizes.

#### Basic Nail Types

Some basic types are shown in figure 3-75. The common nail is designed for rough framing. The box nail is used for toenailing and light work in frame construction. The casing nail is used in finished carpentry work to fasten doors and window casings and other wood trim. The finishing nail and brad are used for light, wood-trim material and are easy to drive below-the surface of lumber with a nail set.

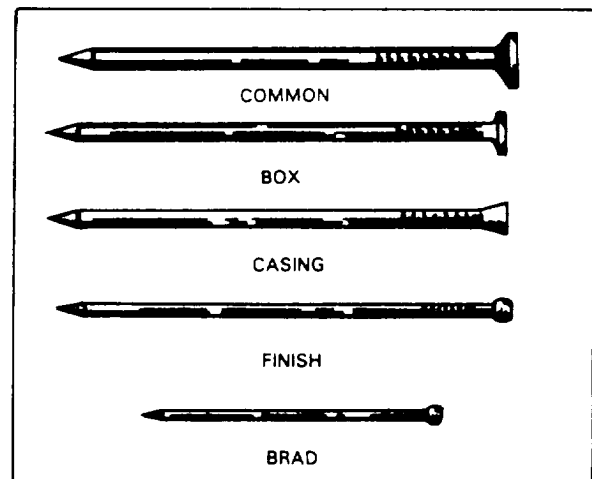

Figure 3-75.-Basic types of nails.

The size of a nail is measured in a unit known as a penny. Penny is abbreviated with the lowercase letter **d**. It indicates the length of the nail. A 6d (6-penny) nail is 2-inches long. A 10d (10-penny) nail is 3-inches long (figure 3-76). These measurements apply to common, box, casing, and finish nails only. Brads and small box nails are identified by their actual length and gauge number.

A nail, whatever the type, should be at least three times as long as the thickness of the wood it is intended to hold. Two-thirds of the length of the nail is driven into the other piece of wood for proper anchorage. The other one-third of the length provides the necessary anchorage of the

piece being fastened. Protruding nails should be bent over to prevent damage to materials and injury to personnel.

There are a few general rules to be followed in the use of nails in building. Nails should be driven at an angle slightly toward each other to improve their holding power. You should be careful in placing nails to provide the greatest holding power. Nails driven with the grain do not hold as well as nails driven across the grain. A few nails of proper type and size, properly placed and properly driven, will hold better than a great many driven close together. Nails can generally be considered the cheapest and easiest fasteners to be applied.

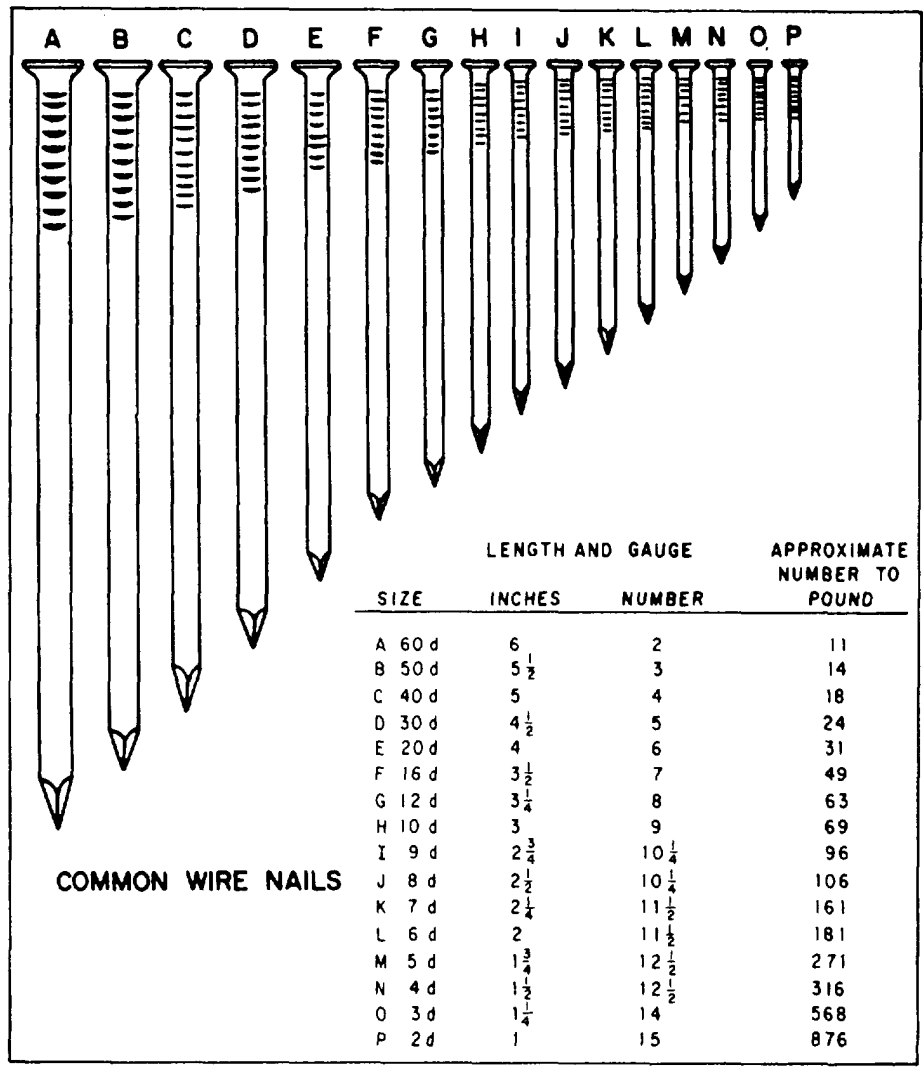

Figure 3-76.-Nail sizes given in "penny" (d) units.

## Specialty Nails

Figure 3-77 shows a few of the many specialized nails. Some nails are specially coated with zinc, cement, or resin materials. Some have threading for increased holding power of the nails. Nails are made from many materials, such as iron, steel, copper, bronze, aluminum, and stainless steel.

Annular and spiral nails are threaded for greater holding power. They are good for fastening paneling or plywood flooring. The drywall nail is used for hanging drywall and has a special coating to prevent rust. Roofing nails are not specified by the penny system; rather, they are referred to by length. They are available in lengths from 3/4 inch to 2 inches and have large heads. The double-headed nail, or duplex-head nail, is used for temporary construction, such as form work or scaffolding. The double head on this nail makes it easy to pull out when forms or scaffolding are torn down. Nails for power nailing come in rolls or clips for easy loading into a nailer. They are coated for easier driving and greater holding power. Table 3-10 gives the general size and type of nails preferable for specific applications.

## STAPLES

Staples are available in a wide variety of shapes and sizes, some of which are shown in figure 3-78.

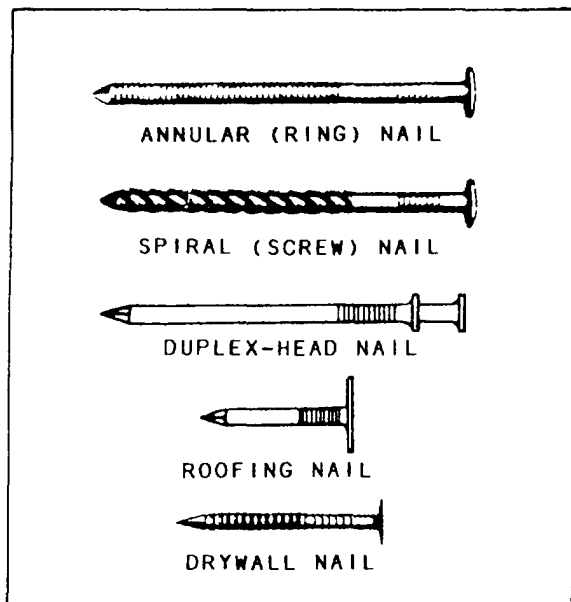

Figure 3-77.-Specialized nails.

Heavy-duty staples are used to fasten plywood sheathing and subflooring. Heavy-duty staples are driven by electrically or pneumatically operated tools. Light-duty and medium-duty staples are used for attaching molding and other interior trim. Staples are sometimes driven in by hand-operated tools.

## SCREWS

The use of screws, rather than nails, as fasteners may be dictated by a number of factors. These may include the type of material to be fastened, the requirement for greater holding power than can be obtained by the use of nails, the finished appearance desired, and the fact that the number of fasteners that can be used is limited. Using screws, rather than nails, is more expensive in terms of time and money, but it is often necessary to meet requirements for superior results. The main advantages of screws are that they provide more holding power, can be easily tightened to draw the items being fastened securely together, are neater in appearance if properly driven, and can be withdrawn without damaging the material. The common wood screw is usually made of unhardened steel, stainless steel, aluminum, or brass. The steel may be bright finished or blued, or zinc, cadmium, or chrome plated. Wood screws are threaded from a gimlet point for approximately two-thirds of the length of the screw and are provided with a slotted head designed to be driven by an inserted driver. Wood screws, as shown in figure 3-79, are designated according to head style. The most common types are flathead, oval head, and

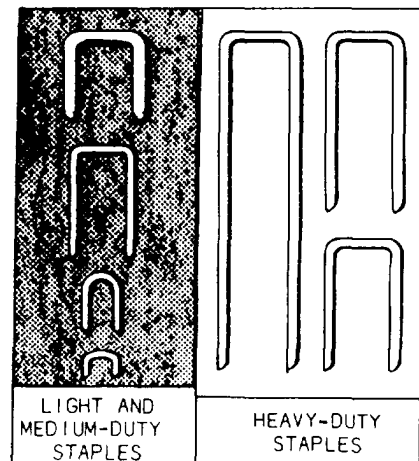

Figure 3-78.-Types of staples.



Table 3-10.-Size, Type, and Use of Nails

SIZE	LENGTH (IN.) <sup>1</sup>	DIAMETER (IN.)	REMARKS	WHERE USED
2d	1	.072	Small head	Finish work, shop work
2d	1	.072	Large flathead	Small timber, wood shingles, lathes
3d	1 1/4	.08	Small head	Finish work, shop work
3d	1 1/4	.08	Large flathead	Small timber, wood shingles, lathes
4d	1 1/2	.098	Small head	Finish work, shop work
4d	1 1/2	.098	Large flathead	Small timber, lathes, shop work
5d	1 3/4	.098	Small head	Finish work, shop work
5d	1 3/4	.098	Large flathead	Small timber, lathes, shop work
6d	2	.113	Small head	Finish work, casing, stops, etc., shop work
6d	2	.113	Large flathead	Small timber, siding, sheathing, etc., shop work
7d	2 1/4	.113	Small head	Casing, base, ceiling, stops, etc.
7d	2 1/4	.113	Large flathead	Sheathing, siding, subflooring, light framing
8d	2 1/2	.131	Small head	Casing, base, ceiling, wainscot, etc., shop work
8d	2 1/2	.131	Large flathead	Sheathing, siding, subflooring, light framing, shop work
8d	1 1/4	.131	Extra-large flathead	Roll roofing, composition shingles
9d	2 3/4	.131	Small head	Casing, base, ceiling, etc.
9d	2 3/4	.131	Large flathead	Sheathing, siding, subflooring, framing, shop work
10d	3	.148	Small head	Casing, base, ceiling, etc., shop work
10d	3	.148	Large flathead	Sheathing, siding, subflooring, framing, shop work
12d	3 1/4	.148	Large flathead	Sheathing, subflooring, framing
16d	3 1/2	.162	Large flathead	Framing, bridges, etc.
20d	4	.192	Large flathead	Framing, bridges, etc.
30d	4 1/2	.207	Large flathead	Heavy framing, bridges, etc.
40d	5	.225	Large flathead	Heavy framing, bridges, etc.
50d	5 1/2	.244	Large flathead	Extra-heavy framing, bridges, etc.
60d	6	.262	Large flathead	Extra-heavy framing, bridges, etc.

<sup>1</sup>This chart applies to wire nails, although it may be used to determine the length of cut nails.

roundhead, as illustrated in that order in figure 3-79, All of these screws can have slotted or Phillips heads.

To prepare wood for receiving the screws, bore a body hole the diameter of the screw to be used in the piece of wood that is to be fastened (figure 3-80). You should then bore a starter hole in the base wood with a diameter less than that of the screw threads and a depth of one-half or two-thirds the length of the threads to be anchored. The purpose of this careful preparation is to assure accuracy in the placement of the screws, to reduce the possibility of splitting the wood, and to reduce the time and effort required to drive the screw. Properly set slotted and Phillips flathead and oval head screws are countersunk sufficiently to permit a covering material to be used to cover the head. Slotted roundhead and Phillips roundhead screws are not countersunk, but they are driven so that the head is firmly flush with the surface of the wood. The slot of the roundhead screw is left parallel with the grain of the wood.

The proper name for a lag screw (shown in figure 3-79) is lag bolt or wood screw. These screws are often required in constructing large projects, such as a building. They are longer and much heavier than the common wood screw and have coarser threads that extend from a cone, or gimlet point, slightly more than half the length of the screw. Square-head and hexagonal-head lag screws are always externally driven, usually by means of a wrench. They are used when ordinary wood screws would be too short or too light and spikes would not be strong enough. Sizes of

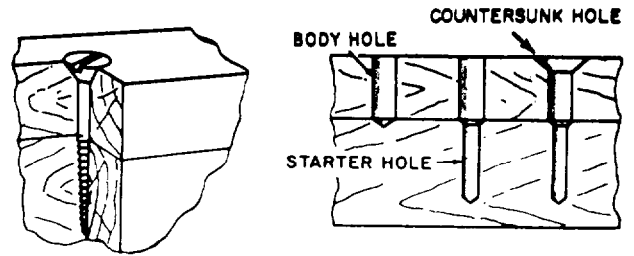

Figure 3-80.-Proper way to sink a screw.

lag screws are shown in table 3-11. Combined with expansion anchors, they are used to frame timbers to existing masonry.

Expansion shields, or expansion anchors as they are sometimes called, are used for inserting a predrilled hole, usually in masonry, to provide a gripping base or anchor for a screw, bolt, or nail intended to fasten an item to the surface in which the hole was bored. The shield can be obtained separately, or it may include the screw, bolt, or nail. After the expansion shield is inserted in the predrilled hole, the fastener is driven into the hole in the shield, expanding the shield and wedging it firmly against the surface of the hole.

For the assembly of metal parts, sheet metal screws are used. These screws are made regularly in steel and brass with four types of heads: flat, round, oval, and fillister, as shown in that order in figure 3-79.

Wood screws come in sizes that vary from 1/4 inch to 6 inches. Screws up to 1-inch in length increase by

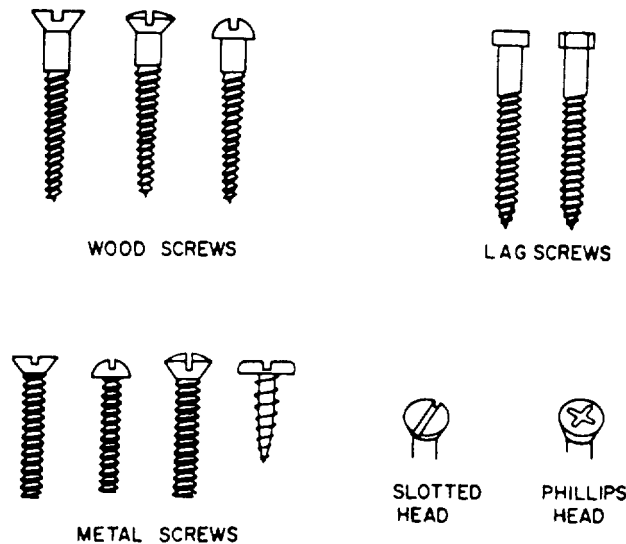

Figure 3-79.-Types of screws.

Table 3-11.-Lag Screw Sizes

LENGTH (INCHES)	DIAMETER (INCHES)			
	1/4	3/8 7/16 1/2	5/8 3/4	7/8 1
1	×	×		
1 1/2	×	×	×	
2, 2 1/2, 3 3/2, etc., 7 1/2 8 to 10	×	×	×	×
11 to 12		×	×	×
13 to 16			×	×

eighths, screws from 1 to 3 inches increase by quarters, and screws from 3 to 6 inches increase by half inches. Screws vary in length and size of shaft. Each length is made in a number of shaft sizes specified by an arbitrary number that represents no particular measurement but indicates relative differences in the diameter of the screws. Proper nomenclature of a screw, as shown in figure 3-81, includes the type, material, finish, length, and screw size number, which indicates the wire gauge of the body, drill or bit size for the body hole, and drill or bit size for the starter hole. Tables 3-12 and 3-13 provide size, length, gauge, and applicable drill and auger bit sizes for screws. Table 3-11 gives lengths and diameters of lag screws.

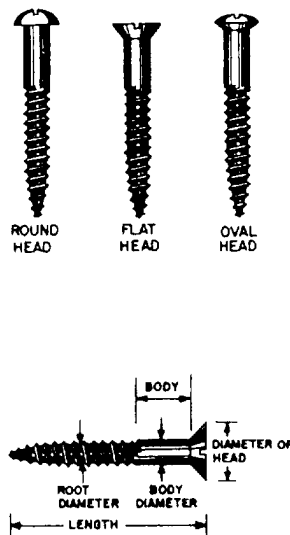

Figure 3-81.-Types and nomenclature of wood screws.

## BOLTS

Bolts are used in construction when great strength is required or when the work under construction must be frequently disassembled. Their use usually implies the use of nuts for fastening and, sometimes, the use of washers to protect the surface of the material they are used to fasten. Bolts are selected for application to specific requirements in terms of length, diameter, threads, style of head, and type. Proper selection of head style and type of bolt results in good appearance as well as good construction. The use of washers between the nut and a wood surface or between both the nut and the head and their opposing surfaces helps you avoid marring the surfaces and permits additional torque in tightening.

### Carriage Bolts

Carriage bolts fall into three categories: square neck finned neck and ribbed neck (figure 3-82). These bolts have round heads that are not designed to

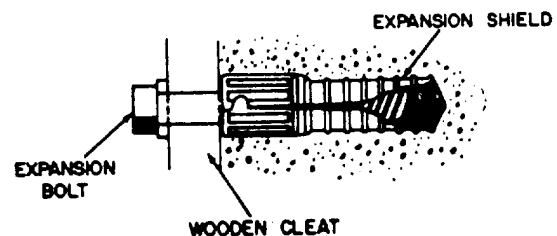
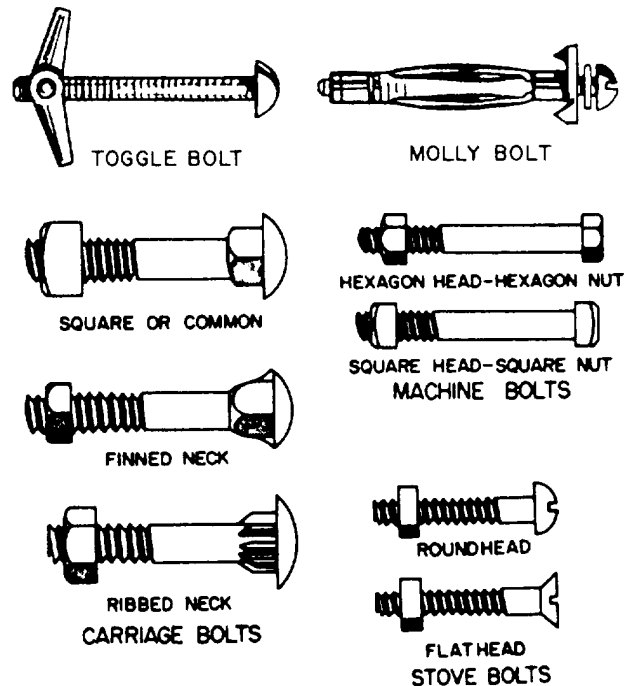

Figure 3-82.-Types of bolts.

Table 3-12.-Screw Sizes and Dimensions

LENGTH (In.)	SIZE NUMBERS																					
	0	1	2	3	4	5	6	7	8	9	10	11	12	13	14	15	16	17	18	20	22	24
1/4	x	x	x	x																		
3/8	x	x	x	x	x	x	x	x	x	x												
1/2		x	x	x	x	x	x	x	x	x	x	x										
5/8		x	x	x	x	x	x	x	x	x	x	x			x							
3/4			x	x	x	x	x	x	x	x	x	x			x		x					
7/8			x	x	x	x	x	x	x	x	x	x			x		x					
1				x	x	x	x	x	x	x	x	x			x		x			x	x	
1 1/4					x	x	x	x	x	x	x	x			x		x			x	x	x
1 1/2					x	x	x	x	x	x	x	x			x		x			x	x	x
1 3/4						x	x	x	x	x	x	x			x		x			x	x	x
2						x	x	x	x	x	x	x			x		x			x	x	x
2 1/4						x	x	x	x	x	x	x			x		x			x	x	x
2 1/2						x	x	x	x	x	x	x			x		x			x	x	x
2 3/4							x	x	x	x	x	x			x		x			x	x	x
3							x	x	x	x	x	x			x		x			x	x	x
3 1/2									x	x	x	x			x		x			x	x	x
4									x	x	x	x			x		x			x	x	x
4 1/2												x			x		x			x	x	x
5													x		x		x			x	x	x
6														x		x				x	x	x
THREADS PER INCH	32	28	26	24	22	20	18	16	15	14	13	12	11		10		9		8	8		7
DIA OF SCREW (In.)	.060	.073	.086	.099	.112	.125	.138	.151	.164	.177	.190	.203	.216		.242		.268		.294	.320		.372

Table 3-13.-Drill and Auger Bit Sizes for Wood Screws

SCREW SIZE NO.	1	2	3	4	5	6	7	8	9	10	12	14	16	18	
NOMINAL SCREW	.073	.086	.099	.112	.125	.138	.151	.164	.177	.190	.216	.242	.268	.294	
BODY DIAMETER	$\frac{5}{64}$	$\frac{3}{32}$	$\frac{3}{32}$	$\frac{7}{64}$	$\frac{1}{8}$	$\frac{9}{64}$	$\frac{5}{32}$	$\frac{11}{64}$	$\frac{11}{64}$	$\frac{3}{16}$	$\frac{7}{32}$	$\frac{15}{64}$	$\frac{17}{64}$	$\frac{19}{64}$	
PILOT HOLE	Drill size	$\frac{5}{64}$	$\frac{3}{32}$	$\frac{7}{64}$	$\frac{7}{64}$	$\frac{1}{8}$	$\frac{9}{64}$	$\frac{5}{32}$	$\frac{11}{64}$	$\frac{3}{16}$	$\frac{3}{16}$	$\frac{7}{32}$	$\frac{1}{4}$	$\frac{17}{64}$	$\frac{19}{64}$
	Bit size	—	—	—	—	—	—	—	—	—	—	4	4	5	5
STARTER HOLE	Drill size	—	$\frac{1}{16}$	$\frac{1}{16}$	$\frac{5}{64}$	$\frac{5}{64}$	$\frac{3}{32}$	$\frac{7}{64}$	$\frac{7}{64}$	$\frac{1}{8}$	$\frac{1}{8}$	$\frac{9}{64}$	$\frac{5}{32}$	$\frac{3}{16}$	$\frac{13}{64}$
	Bit size	—	—	—	—	—	—	—	—	—	—	—	—	—	4

Table 3-14.-Carriage Bolt Sizes

LENGTH (INCHES)	DIAMETER (INCHES)			
	3/16, 1/4, 5/16, 3/8	7/16, 1/2	9/16, 5/8	3/4
3/4	×	—	—	—
1	×	×	—	—
1 1/4	×	×	×	—
1 1/2, 2, 2 1/2, etc., 9 1/2, 10 to 20	×	×	×	×

be driven. They are threaded only part of the way up the shaft. Usually, the threads are two to four times the diameter of the bolt in length. In each type of carriage bolt, the upper part of the shank, immediately below the head, is designed to grip the material in which the bolt is inserted and keep the bolt from turning when a nut is tightened down on it or removed. The finned type is designed with two or more fins extending from the head to the shank. The ribbed type is designed with longitudinal ribs, splines, or serrations on all or part of a shoulder located immediately beneath the head. Holes bored to receive carriage bolts are bored to be a tight fit for the body of the bolt and counterbored to permit the head of the bolt to fit flush with, or below the surface of, the material being fastened. The bolt is then driven through the hole with a hammer. Carriage bolts are chiefly for wood-to-wood application, but they can also be used for wood-to-metal applications. If used for wood-to-metal application, the head should be fitted to the wood item. Metal surfaces are sometimes predrilled and countersunk to permit the use of carriage bolts metal to metal. Carriage bolts can be obtained from 1/4 inch to 1 inch in diameter and from 3/4 inch to 20 inches long (table 3-14). A common

flat washer should be used with carriage bolts between the nut and the surface.

**Machine Bolts**

Machine bolts (figure 3-82) are made with cut national fine and national coarse threads extending in length from twice the diameter of the bolt plus 1/4 inch (for bolts less than 6 inches in length) to twice the diameter of the bolt plus 1/2 inch (for bolts over 6 inches in length). They are precision made and generally applied metal to metal where close tolerance is desirable. The head may be square, hexagonal, rounded, or flat countersunk. The nut usually corresponds in shape to the head of the bolt with which it is used. Machine bolts are externally driven only. Selection of the proper machine bolt is made on the basis of head style, length, diameter, number of threads per inch, and coarseness of thread. The hole through which the bolt is to pass is bored to the same diameter as the bolt. Machine bolts are made in diameters from 1/4 inch to 3 inches and may be obtained in any length desired (table 3- 15).

Table 3-15.-Machine Bolt Sizes

LENGTH (INCHES)	DIAMETER (INCHES)				
	1/4, 3/8	7/16	1/2, 9/16, 5/8	1/2, 7/8, 1	1 1/8, 1 1/4
3/4	×	—	—	—	—
1 1/4	×	×	×	—	—
1 1/2, 2, 2 1/2	×	×	×	×	—
3, 3 1/2, 4, 4 1/2, etc., 9 1/2, 10 to 20	×	×	×	×	×
21 to 25	—	—	×	×	×
26 to 39	—	—	—	×	×

## Stove Bolts

Stove bolts (figure 3-82) are less precisely made than machine bolts. They are made with either flat or round slotted heads and may have threads extending over the full length of the body, over part of the body, or over most of the body. They are generally used with square nuts and applied metal to metal, wood to wood, or wood to metal. If flatheaded, they are countersunk. If roundheaded, they are drawn flush to the surface.

## Expansion Bolt

An expansion bolt (figure 3-82) is a bolt used in conjunction with an expansion shield to provide anchorage in substances in which a threaded fastener alone is useless. The shield, or expansion anchor, is inserted in a predrilled hole and expands when the bolt is driven into it. It becomes wedged firmly in the hole, providing a secure base for the grip of the fastener.

## Toggle Bolts

A toggle bolt (figure 3-82) is a machine screw with a spring-action, wing-head nut that folds back as the entire assembly is pushed through a prepared hole in a hollow wall. The wing head then springs open inside the wall cavity. As the screw is tightened, the wing head is drawn against the inside surface of the finished wall material. Spring-action, wing-head toggle bolts are available in a variety of machine screw combinations. Common sizes range from 1/8 inch to 3/8 inch in diameter and 2 inches to 6 inches in length. They are particularly useful with sheetrock wall surfaces.

## Molly Bolt

The molly bolt or molly expansion anchor (figure 3-82) is used to fasten small cabinets, towel bars, drapery hangers, mirrors, electrical fixtures, and other lightweight items to hollow walls. It is inserted in a prepared hole. Prongs on the outside of the shield grip the wall surfaces to prevent the shield from turning as the anchor screw is being driven. As the screw is tightened, the shield spreads and flattens against the interior of the wall. Various sizes of screw anchors can be used in hollow walls 1/8 inch to 1 3/4 inches thick.

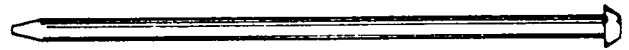

Figure 3-83.-Driftpin (driftbolt).

## Driftpins

Driftpins are long, heavy, threadless bolts used to hold heavy pieces of timber together (figure 3-83). They have heads that vary in diameter from 1/2 to 1 inch and in length from 18 to 26 inches. The term "driftpin" is almost universally used in practice. However, for supply purposes, the correct designation is driftbolt.

To use the driftpin, you make a hole slightly smaller than the diameter of the pin in the timber. The pin is driven into the hole and is held in place by the compression action of the wood fibers.

## CORRUGATED FASTENERS

The corrugated fastener is one of the many means by which joints and splices are fastened in small timber and boards. It is used particularly in the miter joint. Corrugated fasteners are made of 18- to 22-gauge sheet metal with alternate ridges and grooves; the ridges vary from 3/16 to 5/16 inch, center to center. One end is cut square; the other end is sharpened with beveled edges. There are two types of corrugated fasteners: one with the ridges running parallel (figure 3-84, view A); the other with ridges running at a slight angle to one another (figure 3-84, view B). The latter type has a tendency to compress the material since the ridges and grooves are closer at the top than at the bottom. These fasteners are made in several different lengths and widths. The width varies from 5/8 to 1 1/8 inches; the length varies from 1/4 to 3/4 inch. The fasteners also are made with different numbers of ridges, ranging from three to six ridges per fastener. Corrugated fasteners are used in a number of ways—to fasten parallel boards together, as in fastening tabletops; to make any type of joint; and as a substitute for nails where nails may split the timber. In small timber, corrugated fasteners have greater holding power than nails. The proper method of using the fasteners is shown in figure 3-84.

## ADHESIVES

Seabees use many different types of adhesives in various phases of their construction projects. Glues

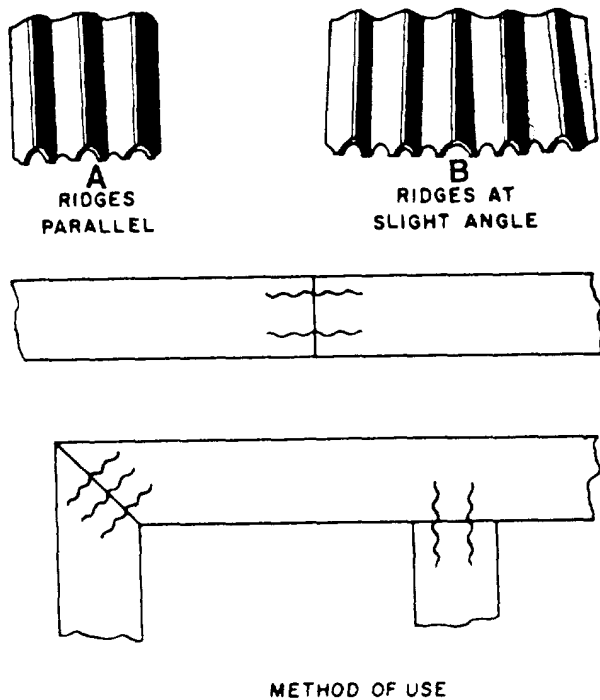

Figure 3-84.-Corrugated fasteners and their uses.

(which have a plastic base) and mastics (which have an asphalt, rubber, or resin base) are the two major categories of adhesives.

The method of applying adhesives, their drying time, and their bonding characteristics vary. Some adhesives are more resistant to moisture and to hot and cold temperatures than others.

#### SAFETY NOTE

Some adhesives are highly flammable; they should be used only in a well-ventilated work area. Others are highly irritating to the skin and eyes. **ALWAYS FOLLOW MANUFACTURER'S INSTRUCTIONS WHEN USING ADHESIVES.**

#### Glues

The primary function of glue is to hold together joints in mill and cabinet work. Most modern glues have a plastic base. Glues are sold as a powder to which water must be added or in liquid form. Many types of glue are available under brand names. A brief description of some of the more popular types of glue is listed below.

Polyvinyl resin, or white glue, is a liquid that comes in ready-to-use plastic squeeze bottles. It does

a good job of bonding wood together, and it sets up (dries) quickly after being applied. Because white glue is not waterproof, it should not be used on work that will be subjected to constant moisture or high humidity.

Urea resin is a plastic based glue that is sold in a powder form. The required amount is mixed with water when the glue is needed. Urea resin makes an excellent bond for wood and has fair water resistance.

Phenolic resin glue is highly resistant to temperature extremes and water. It is often used for bonding the veneer layers of exterior grade plywood.

Resorcinol glue has excellent water resistance and temperature resistance, and it makes a very strong bond. Resorcinol resin is often used for bonding the wood layers of laminated timbers.

Contact cement is used to bond plastic laminates to wood surfaces. This glue has a neoprene rubber base. Because contact cement bonds very rapidly, it is useful for joining parts that cannot be clamped together.

#### Mastics

Mastics are widely used throughout the construction industry. The asphalt, rubber, or resin base of mastics gives them a thicker consistency. Mastics are sold in cans, tubes, or canisters that fit into hand-operated or air-operated caulking guns.

These adhesives can be used to bond materials directly to masonry or concrete walls. If furring strips are required on a wavy concrete wall, the strips can be applied with mastic rather than by the more difficult procedure of driving in concrete nails. You can also fasten insulation materials to masonry and concrete walls with a mastic adhesive. Mastics can also be used to bond drywall (gypsum board) directly to wall studs. They can also be used to bond gypsum board to furring strips or directly to concrete or masonry walls. Because you don't use nails, there are no nail indentations to fill.

By using mastic adhesives, you can apply paneling with very few or no nails at all. Wall panels can be bonded to studs, furring strips, or directly against concrete or masonry walls. Mastic adhesives can be used with nails or staples to fasten plywood panels to floor joists. The mastic adhesive helps eliminate squeaks, bounce, and nail popping. It also increases the stiffness and strength of the floor unit.

## RECOMMENDED READING LIST

### NOTE

Although the following references were current when this TRAMAN was published, their continued currency cannot be assured.

You therefore need to ensure that you are studying the latest revision.

*Carpentry I*, Headquarters, EN5155, U.S. Army Engineering School, Fort Belvoir, Va., 1988.

*Carpentry III*, Headquarters, EN0533, U.S. Army Engineering School, Fort Belvoir, Va., 1987.



# FIBER LINE, WIRE ROPE, AND SCAFFOLDING

This chapter presents information on how to use fiber line, wire rope, and timber in rigging and erecting hoisting devices (such as shear legs, tripods, blocks and tackles), and different types of scaffolds and ladders. Formulas are given on how to determine or find the safe working load of these materials.

## FIBER LINE

**LEARNING OBJECTIVE:** Upon completing this section, you should be able to determine the use, breaking strength, and care officer lines and rope used for rigging.

Fiber line is made from either natural or synthetic fiber. Natural fibers, which come from plants, include manila, sisal, and hemp. The synthetic fibers include nylon, polyester, and polypropylene.

### NATURAL FIBER ROPES

The two most commonly used natural fiber ropes are manila and sisal, but the only type suitable for construction rigging is a good grade of manila. High-quality manila is light cream in color, smooth, clean, and pliable. The quality of the line can be distinguished by varying shades of brown: Number 1 grade is very light in color; Number 2 grade is slightly darker; Number 3 grade is considerably darker. The next best line-making fiber is sisal. The sisal fiber is similar to manila, but it is lighter in color. This type of fiber is only about 80 percent as strong as manila fiber.

### SYNTHETIC FIBER ROPES

Synthetic fiber rope, such as nylon and polyester, has rapidly gained wide use by the Navy. It is lighter in weight, more flexible, less bulky, and easier to handle and store than manila line. It is also highly resistant to mildew, rot, and fungus. Synthetic rope is stronger than natural fiber rope. For example, nylon is about three times stronger than manila. When

nylon line is wet or frozen, the loss of strength is relatively small. Nylon rope will hold a load even though several stands may be frayed. Ordinarily, the line can be made reusable by cutting away the chafed or frayed section and splicing the good line together.

## FABRICATION OF LINE

The fabrication of line consists essentially of three twisting operations. First, the fibers are twisted to the right to form the yarns. Next, the yarns are twisted to the left to form the strands. Finally, the strands are twisted to the right to form the line. Figure 4-1 shows you how the fibers are grouped to form a three-strand line.

The operation just described is the standard procedure, and the resulting product is known as a right-laid line. When the process is reversed, the result is a left-laid line. In either instance, the principle of opposite twists must always be observed. The two main reasons for the principle of opposite twists are to keep the line tight to prevent the fibers from unlaying with a load suspended on it and to prevent moisture penetration.

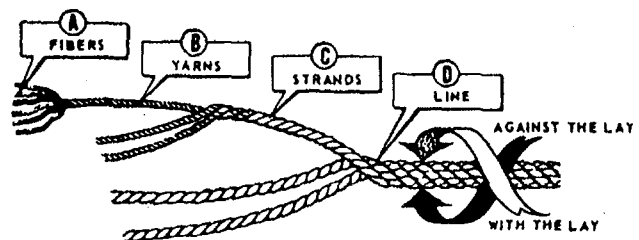

Figure 4-1.—Fiber groupings in a three-strand line.

## Types of Line Lays

There are three types of fiber line lays: hawser-laid, shroud-laid, and cable-laid lines. Each type is illustrated in figure 4-2.

Hawser-laid line generally consists of three strands twisted together, usually in a right-hand direction. A shroud-laid line ordinarily is composed of four strands twisted together in a right-hand direction around a center strand, or core, which usually is of the same material, but smaller in diameter than the four strands. You will find that shroud-laid line is more pliable and stronger than hawser-laid line, but it has a strong tendency toward kinking. In most instances, it is used on sheaves and drums. This not only prevents kinking, but also makes use of its pliability and strength. Cable-laid line usually consists of three right-hand, hawser-laid lines twisted together in a left-hand direction. It is especially safe to use in heavy construction work; if cable laid line untwists, it will tend to tighten any regular right-hand screw connection to which it is attached.

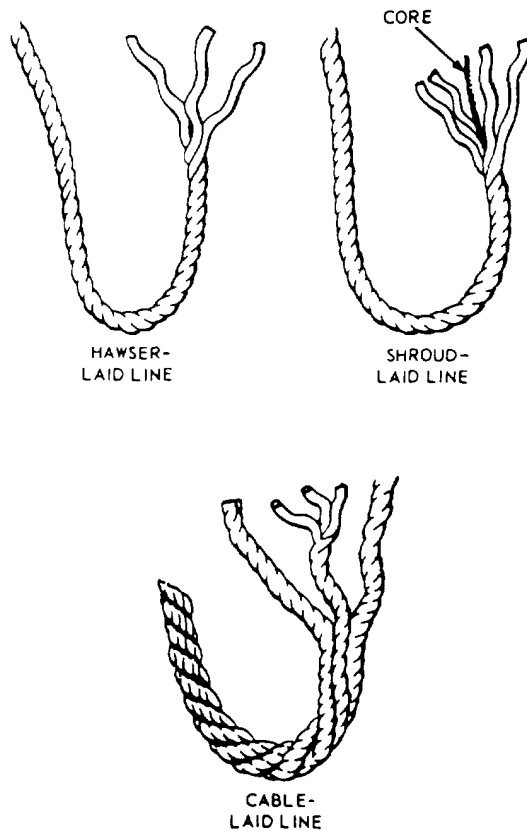

Figure 4-2.—Time type of fiber line.

## Size Designation

Line that is 1 3/4 inches or less in circumference is called small stuff this size is usually designated by the number of threads (or yarns) that make up each strand. You may use from 6- to 24-thread strands, but the most commonly used are 9- to 21-thread strands (figure 4-3). You may hear some small stuff designated by name without reference to size. One such type is marline—a tarred, two-strand, left-laid hemp. Marline is the small stuff you will use most for seizing. When you need something stronger than marline, you will use a tarred, three-strand, left-laid hemp called houseline.

Line larger than 1 3/4 inches in circumference is generally size designated by its circumference in inches. A 6-inch manila line, for instance, is constructed of manila fibers and measures 6 inches in circumference. Line is available in sizes ranging up to 16 inches in circumference, but 12 inches is about the largest carried in stock. Anything larger is used only on special jobs.

If you have occasion to order line, you may find that in the catalogs, it is designated and ordered by diameter. The catalog may also use the term “rope” rather than “line.”

Rope yarns for temporary seizing, whippings, and lashings are pulled from large strands of old line that

MANILA LINE			
SOME COMMONLY USED SIZES	* CIRCUMFERENCE		THREAD
	INCHES	MILLIMETERS	
	3/4	19.05	6
	1	25.40	9
	1 1/8	28.58	12
	1 1/4	31.76	15
	1 1/2	38.10	21
	1 3/4	44.45	24
	2	50.80	
	3	76.20	
	4	101.6	
	5	127.0	
	6	152.4	

\* SIZE IS DESIGNATED BY THE CIRCUMFERENCE

Figure 4-3.—Some commonly used sizes of manila line.

has outlived its usefulness. Full your yarn from the middle, away from the ends, or it will get fouled.

## STRENGTH OF FIBER LINE

Overloading a line poses a serious threat to the safety of personnel, not to mention the heavy losses likely to result through damage to material. To avoid overloading, you must know the strength of the line with which you are working. This involves three factors: breaking strength, safe working load (swl), and safety factor.

Breaking strength refers to the tension at which the line will part when a load is applied. Breaking strength has been determined through tests made by rope manufacturers, who provide tables with this information. In the absence of manufacturers' tables, a rule of thumb for finding the breaking strength of manila line using the formula:  $C^2 \times 900 = BS$ . C equals the circumference in inches, and BS equals the breaking strength in pounds. To find BS, first square the circumference; you then multiply the value obtained by 900. With a 3-inch line, for example, you will get a BS of 8,100, or  $3 \times 3 \times 900 = 8,100$  pounds.

The breaking strength of manila line is higher than that of sisal line. This is caused by the difference in strength of the two fibers. The fiber from which a particular line is constructed has a definite bearing on its breaking strength. The breaking strength of nylon line is almost three times that of manila line of the same size.

The best rule of thumb for the breaking strength of nylon is  $BS = C^2 \times 2,400$ . The symbols in the rule are the same as those for fiber line. For 2 1/2-inch nylon line,  $BS = 2.5 \times 2.5 \times 2,400 = 15,000$  pounds.

Briefly defined, the safe working load of a line is the load that can be applied without damaging the line. Note that the safe working load is considerably less than the breaking strength. A wide margin of difference between breaking strength and safe working load is necessary. This difference allows for such factors as additional strain imposed on the line by jerky movements in hoisting or bending over sheaves in a pulley block.

You may not always have a chart available to tell you the safe working load for a particular size line. Here is a rule of thumb that will adequately serve your needs on such an occasion:  $swl = C^2 \times 150$ . In this equation, swl equals the safe working load in pounds, and C equals the circumference of the line in inches.

Simply take the circumference of the line, square it, then multiply by 150. For a 3-inch line,  $3 \times 3 \times 150 = 1,350$  pounds. Thus, the safe working load of a 3-inch line is equal to 1,350 pounds.

If line is in good shape, add 30 percent to the swl arrived at by means of the preceding rule; if it is in bad shape, subtract 30 percent from the swl. In the example given above for the 3-inch line, adding 30 percent to the 1,350 pounds gives you a safe working load of 1,755 pounds. On the other hand, subtracting 30 percent from the 1,350 pounds leaves you with a safe working load of 945 pounds.

Remember that the strength of a line decreases with age, use, and exposure to excessive heat, boiling water, or sharp bends. Especially with used line, these and other factors affecting strength should be given careful consideration and proper adjustment made in determining the breaking strength and safe working load capacity of the line. Manufacturers of line provide tables that show the breaking strength and safe working load capacity of line. You will find such tables very useful in your work. You must remember, however, that the values given in manufacturers' tables only apply to new line being used under favorable conditions. For that reason, you must progressively reduce the values given in manufacturers' tables as the line ages or deteriorates with use.

Keep in mind that a strong strain on a kinked or twisted line will put a permanent distortion in the line. Figure 4-4 shows what frequently happens when pressure is applied to a line with a kink in it. The kink that could have been worked out is now permanent, and the line is ruined.

The safety factor of a line is the ratio between the breaking strength and the safe working load. Usually, a safety factor of 4 is acceptable, but this is not always the case. In other words, the safety factor varies depending on such things as the condition of the line and circumstances under which it is to be used. Although the safety factor should never be less than 3, it often must be well above 4 (possibly as high as 8 or

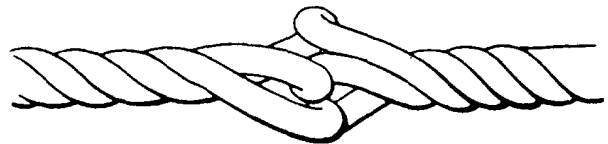

Figure 4-4.—Results of a strong strain on a line with a kink in it.

10), For best, average, or unfavorable conditions, the following safety factors may often be suitable:

- Best conditions (new line): 4;
- Average conditions (line used, but in good condition): 6; and
- Unfavorable conditions (frequently used line, such as running rigging): 8.

## HANDLING AND CARE OF LINES

If you expect the fiber line you work with to give safe and dependable service, make sure it is handled and cared for properly. Study the precautions and procedures given here and carry them out properly.

Cleanliness is part of the care of fiber line. Never drag a line over the deck or ground, or over rough or dirty surfaces. The line can easily pick up sand and grit, which will work into the strands and wear the fibers. If a line does get dirty, use only water to clean it. Do not use soap because it will remove oil from the line, thereby weakening it.

Avoid pulling a line over sharp edges because the strands may break. When you encounter a sharp edge, place chafing gear, such as a board, folded cardboard or canvas, or part of a rubber tire between the line and the sharp edge to prevent damaging the line.

Never cut a line unless you have to. When possible, always use knots that can be untied easily.

Fiber line contracts, or shrinks, when it gets wet. If there is not enough slack in a wet line to permit shrinkage, the line is likely to become overstrained and weakened. If a taut line is exposed to rain or dampness, make sure the line, while still dry, is slackened to allow for the shrinkage.

Line should be inspected carefully at regular intervals to determine whether it is safe. The outside of a line does not show the condition of the line on the inside. Untwisting the strands slightly allows you to check the condition of the line on the inside. Mildewed line gives off a musty odor. Broken strands or yarns usually can be spotted immediately by a trained observer. You will want to look carefully to ensure there is not dirt or sawdust-like material inside the line. Dirt or other foreign matter inside reveals possible damage to the internal structure of the line. A smaller circumference of the line is usually a sure sign that too much strain has been applied to the line.

For a thorough inspection, a line should be examined at several places along its length. **Only one weak spot—anywhere in a line—makes the entire line weak.** As a final check, pull out a couple of fibers from the line and try to break them. Sound fibers show a strong resistance to breakage.

If an inspection discloses any unsatisfactory conditions in a line, make sure the line is destroyed or cut up in small pieces as soon as possible. This precaution prevents the defective line from being used for hoisting.

## WIRE ROPE

*LEARNING OBJECTIVE: Upon completing this section, you should be able to determine the use, breaking strength, and care of wire rope used for rigging.*

During the course of a project, Seabees often need to hoist or move heavy objects. Wire rope is used for heavy-duty work. The characteristics, construction, and usage of many types of wire rope are discussed in the following paragraphs. We will also discuss the safe working load, use of attachments and fittings, and procedures for the care and handling of wire rope.

## CONSTRUCTION

Wire rope consists of three parts: wires, strands, and core (figure 4-5). In the manufacture of rope, a number of wires are laid together to form the strand. Then a number of strands are laid together around a core to form the rope.

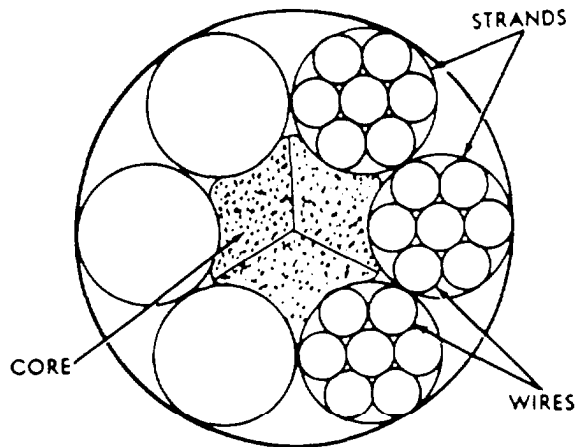

Figure 4-5.—Parts of wire rope.

The basic unit of wire rope construction is the individual wire, which may be made of steel, iron, or other metal in various sizes. The number of wires to a strand varies, depending on the purpose for which the rope is intended. Wire rope is designated by the number of strands per rope and the number of wires per strand. Thus, a 1/2-inch 6-by-19 rope will have 6 strands with 19 wires per strand; but it will have the same outside diameter as a 1/2-inch 6-by-37 wire rope, which will have 6 strands with 37 wires of much smaller size per strand. Wire rope made up of a large number of small wires is flexible, but the small wires are easily broken, so the wire rope does not resist external abrasion. Wire rope made up of a smaller number of larger wires is more resistant to external abrasion but is less flexible.

The core is the element around which the strands are laid to form the rope. It may be a hard fiber (such as manila, hemp, plastic, paper, asbestos, or sisal), a wire strand, or an independent wire rope. Each type of core serves the same basic purpose—to support the strands laid around it.

A fiber core offers the advantage of increased flexibility. Also, it serves as a cushion to reduce the effects of sudden strain and acts as a reservoir for the oil to lubricate the wires and strands to reduce friction between them. Wire rope with a fiber core is used in places where flexibility of the rope is important.

A wire strand core not only resists heat more than a fiber core, but also adds about 15 percent to the strength of the rope. On the other hand, the wire strand makes the rope less flexible than a fiber core.

An independent wire rope core is a separate wire rope over which the main strands of the rope are laid. It usually consists of six, seven-wire strands laid around either a fiber core or a wire strand core. This core strengthens the rope more, provides support against crushing, and supplies maximum resistance to heat.

Wire rope may be made by either of two methods. If the strands or wires are shaped to conform to the curvature of the finished rope before laying up, the rope is termed “preformed.” If they are not shaped before fabrication, the rope is termed “nonpreformed.” When cut, preformed wire rope tends not to unlay, and it is more flexible than nonpreformed wire rope. Wire nonpreformed wire rope, twisting produces a stress in the wires; and, when it is cut or broken, the stress causes the strands to unlay. **In nonpreformed wire, unlaying is rapid**

**and almost instantaneous, which could cause serious injury to someone not familiar with it.**

The main types of wire rope used by the Navy consist of 6, 7, 12, 19, 24, or 37 wires in each strand. Usually, the rope has six strands laid around a fiber or steel center. Two common types of wire rope, 6-by-19 and 6-by-37 rope, are illustrated in views A and B of figure 4-6, respectively. The 6-by-19 type of rope, having 6 strands with 19 wires in each strand, is commonly used for rough hoisting and skidding work where abrasion is likely to occur. The 6-by-37 wire rope, having 6 strands with 37 wires in each strand, is the most flexible of the standard 6-strand ropes. For that reason, it is particularly suitable when small sheaves and drums are to be used, such as on cranes and similar machinery.

## GRADES OF WIRE ROPE

Wire rope is made in a number of different grades. Three of the most common are mild plow steel, plow steel, and improved plow steel.

Mild plow steel rope is tough and pliable. It can stand up under repeated strain and stress, and it has a tensile strength of from 200,000 to 220,000 pounds per square inch (psi). Plow steel wire rope is unusually tough and strong. It has a tensile strength (resistance to lengthwise stress) of 220,000 to 240,000 psi. This rope is suitable for hauling, hoisting, and logging. Improved plow steel rope is one of the best grades of rope available, and most, if not all, of the wire rope in your work will probably be made of this material. It is stronger, tougher, and more resistant to wear than either plow steel or mild plow steel. Each square inch of improved plow steel can withstand a strain of 240,000 to 260,000 psi.

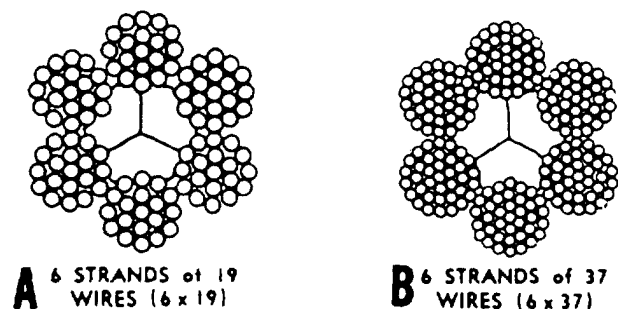

Figure 4-6.—Two common types of wire rope.

## MEASURING WIRE ROPE

The size of wire rope is designated by its diameter. The true diameter of a wire rope is the diameter of a circle that will just enclose all of its strands. Correct and incorrect methods of measuring wire rope are illustrated in figure 4-7. In particular, note that the correct way is to measure from the top of one strand to the top of the strand directly opposite it. The wrong way is to measure across two strands side by side. Use calipers to take the measurement. If calipers are not available, an adjustable wrench will do.

To ensure an accurate measurement of the diameter of a wire rope, always measure the rope at three places, at least 5 feet apart. Use the average of the three measurements as the diameter of the rope.

## SAFE WORKING LOAD

The term "safe working load" (swl), as used in reference to wire rope, means the load that can be applied and still obtain the most efficient service and also prolong the life of the rope. Most manufacturers provide tables that show the safe working load for their rope under various conditions. In the absence of these tables, you must apply a thumb rule formula to obtain the swl. There are rules of thumb that may be used to compute the strength of wire rope. The one recommended by the Naval Facilities Engineering Command (NAVFAC) is  $swl \text{ (in tons)} = D^2 \times 8$ . This particular formula provides an ample safety margin to account for such variables as the number, size, and location of sheaves and drums on which the rope runs. Also included are dynamic stresses, such as the speed of operation and the acceleration and deceleration of the load. All can affect the endurance and breaking strength of the rope.

Let's work an example. In the above formula,  $D$  represents the diameter of the rope in inches. Suppose you want to find the swl of a 2-inch rope. Using the formula above, your figures would be:  $swl = 2^2 \times 8$ , or  $4 \times 8 = 32$ . The answer is 32, meaning that the rope has a swl of 32 tons.

It is very important to remember that any formula for determining swl is only a rule of thumb. In computing the swl of old rope, worn rope, or rope that is otherwise in poor condition, you should reduce the swl as much as 50 percent, depending on the condition of the rope. The manufacturer's data concerning the breaking strength (BS) of wire rope

should be used if available. But if you do not have that information, one rule of thumb recommended is  $BS = C^2 \times 8,000$  pounds.

As you recall, wire rope is measured by the diameter ( $D$ ). To obtain the circumference ( $C$ ) required in the formula, multiply  $D$  by pi (usually shown by the Greek letter  $\pi$ ), which is approximately 3.1416. Thus, the formula to find the circumference is  $C = D\pi$ .

## WIRE ROPE FAILURE

Wire can fail due to any number of causes. Here is a list of some of the common causes of wire rope failure.

- Using the incorrect size, construction, or grade of wire rope;
- Dragging rope over obstacles;
- Having improper lubrication;
- Operating over sheaves and drums of inadequate size;
- Overriding or crosswinding on drums;
- Operating over sheaves and drums with improperly fitted grooves or broken flanges;
- Jumping off sheaves;
- Subjecting it to acid fumes;
- Attaching fittings improperly;
- Promoting internal wear by allowing grit to penetrate between the strands; and
- Subjecting it to severe or continuing overload.

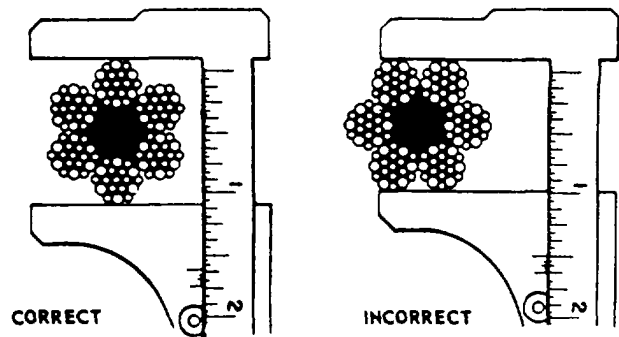

Figure 4-7.—Correct and incorrect methods of measuring wire rope.

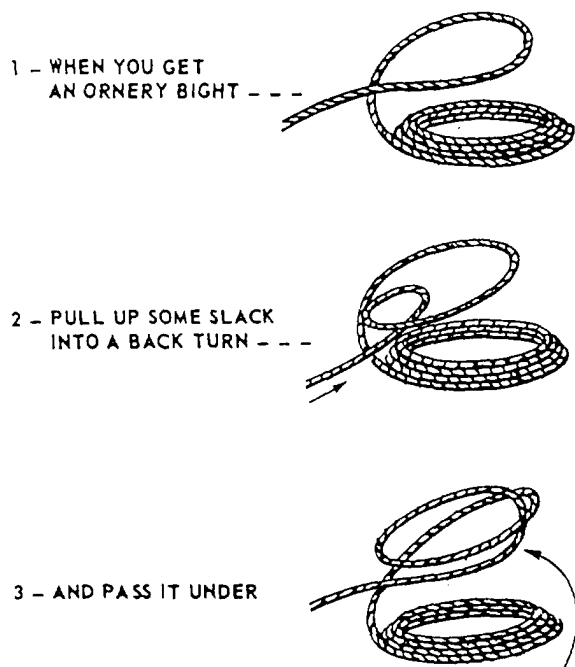

Figure 4-8.—Throwing a back turn to make wire lie down.

## HANDLING AND CARE OF WIRE ROPE

To render safe, dependable service over a maximum period of time, wire rope must have the care and upkeep necessary to keep it in good condition. In this section, we'll discuss various ways of caring for and handling wire rope. Not only should you study these procedures carefully, you should also practice them on your job to help you do a better job now. In the long run, the life of the wire rope will be longer and more useful.

### Coiling and Uncoiling

Once a new reel has been opened, it may be either coiled or faked down like line. The proper direction

of coiling is counterclockwise for left-laid wire rope and clockwise for right-laid rope. Because of the general toughness and resilience of wire, however, it occasionally tends to resist being coiled down. When this occurs, it is useless to fight the wire by forcing down a stubborn turn; it will only spring up again. But if it is thrown in a back turn, as shown in figure 4-8, it will lie down properly. A wire rope, when faked down, will run right off like line; but when wound in a coil, it must always be unwound.

Wire rope tends to kink during uncoiling or unreeling, especially if it has been in service for a long time. A kink can cause a weak spot in the rope, which will wear out quicker than the rest of the rope. A good method for unreeling wire rope is to run a pipe or rod through the center and mount the reel on drum jacks or other supports so the reel is off the ground or deck (figure 4-9.) In this way, the reel will turn as the rope is unwound, and the rotation of the reel will help keep the rope straight. During unreeling, pull the rope straight forward, as shown in figure 4-9, and try to avoid hurrying the operation. As a safeguard against kinking, never unreel wire rope from a stationary reel.

To uncoil a small coil of wire rope, simply stand the coil on edge and roll it along the ground or deck like a wheel or hoop, as illustrated in figure 4-9. Never lay the coil flat on the deck or ground and uncoil it by pulling on the end because such practice can kink or twist the rope.

To rewind wire rope back onto a reel or a drum, you may have difficulty unless you remember that it tends to roll in the direction opposite the lay. For example, a right-laid wire rope tends to roll to the left.

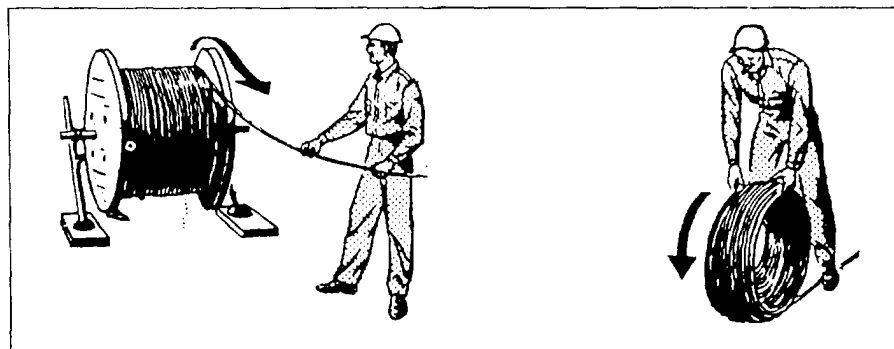
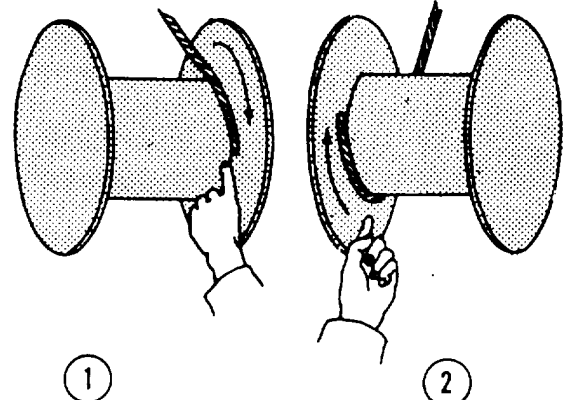
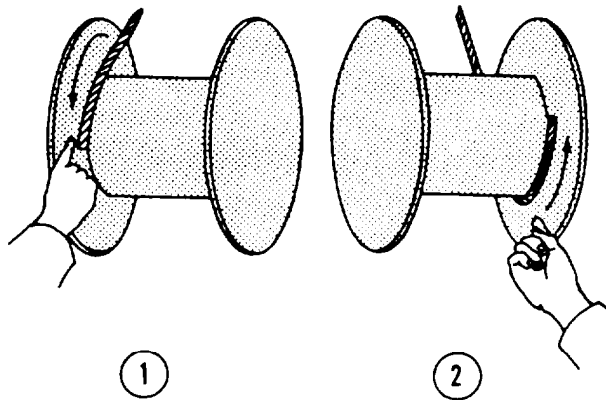

Figure 4-9.—Unreeling wire rope (left) and uncoiling wire rope (right).

**FOR RIGHT-LAY ROPE  
(USE RIGHT HAND)**

**FOR LEFT-LAY ROPE  
(USE LEFT HAND)**



**FOR OVERWIND  
ON DRUM:**

The palm is down, facing the drum.  
The index finger points at on-winding rope.  
The index finger must be closest to the left-side flange.  
The wind of the rope must be from left to right along the drum.

**FOR UNDERWIND  
ON DRUM:**

The palm is up, facing the drum.  
The index finger points at on-winding rope.  
The index finger must be closest to the right-side flange.  
The wind of the rope must be from right to left along the drum.

**FOR OVERWIND  
ON DRUM:**

The palm is down, facing the drum.  
The index finger points at on-winding rope.  
The index finger must be closest to the right-side flange.  
The wind of the rope must be from right to left along the drum.

**FOR UNDERWIND  
ON DRUM:**

The palm is up, facing the drum.  
The index finger points at on-winding rope.  
The index finger must be closest to the left-side flange.  
The wind of the rope must be from left to right along the drum.

If a smooth-face drum has been cut or scored by an old rope, the methods shown may not apply.

Figure 4-10.—Drum windings diagram for selecting the proper lay of rope.

Carefully study figure 4-10, which shows drum-winding diagrams selecting the proper lay of rope. When putting wire rope onto a drum, you should have no trouble if you know the methods of overwinding and underwinding shown in the illustration. When wire rope is run off one reel onto another, or onto a winch or drum, it should be run from top to top or from bottom to bottom, as shown in figure 4-11.

**Kinks**

If a wire rope should form a loop, never try to pull it out by putting strain on either part. As soon as a loop is noticed, uncross the ends by pushing them apart. (See steps 1 and 2 in figure 4-12.) This reverses the process that started the loop. Now, turn

the bent portion over and place it on your knee or some firm object and push downward until the loop straightens out somewhat. (See step 3 in figure 4-12.) Then, lay the bent portion on a flat surface and pound it smooth with a wooden mallet. (See step 4 in figure 4-12.)

If a heavy strain has been put on a wire rope with a kink in it, the rope can no longer be trusted. Replace the wire rope altogether.

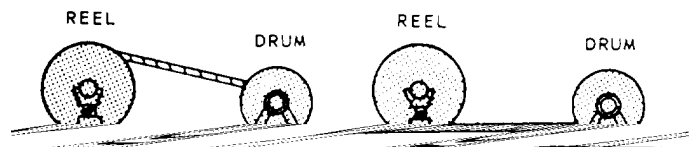

Figure 4-11.—Transferring wire from reel to drum.



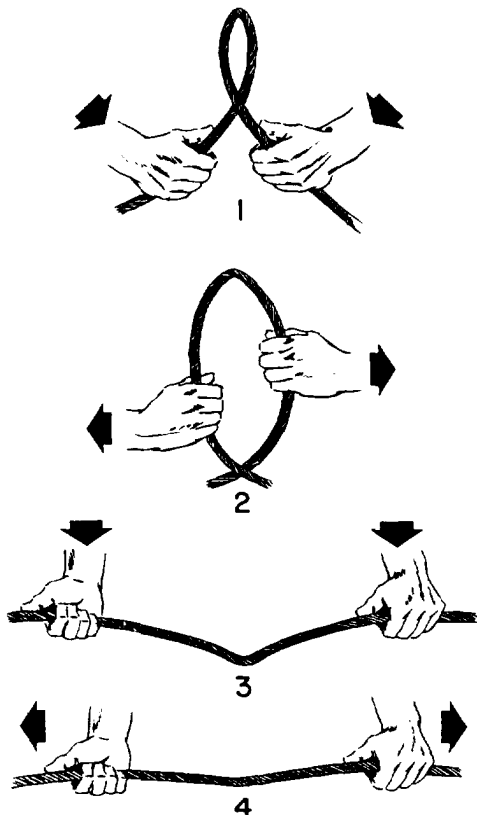

Figure 4-12.—The correct way to takeout a loop in wire rope.

### Lubrication

Used wire rope should be cleaned at frequent intervals to remove any accumulation of dirt, grit, rust, or other foreign matter. The frequency of cleaning depends on how much the rope is used. However, rope should always be well cleaned before lubrication. The rope can be cleaned by wire brushes, compressed air, or steam. Do **not use oxygen** in place of compressed air; it becomes very dangerous when it comes in contact with grease or oil. The purpose is to remove all old lubricant and foreign matter from the valleys between the strands and from the spaces between the outer wires. This gives newly applied lubricant ready entrance into the rope. Wire brushing affords a good opportunity to find any broken wires that may otherwise go unnoticed.

Wire rope is initially lubricated by the manufacturer, but this initial lubrication isn't permanent and periodic reapplications have to be made by the user. Each time a wire rope bends and straightens, the wires in the strands and the strands in the rope slide upon each other. To prevent the rope wearing out by this sliding action, a film of lubricant is needed between the surfaces in contact. The lubricant also helps

prevent corrosion of the wires and deterioration of fiber centers. A rusty wire rope is a liability! With wire rope, the same as with any machine or piece of equipment, proper lubrication is essential to smooth, efficient performance.

The lubricant should be a good grade of lubricating oil, free from acids and corrosive substances. It must also be of a consistency that will penetrate to the center of the core, yet heavy enough to remain as a coating on the outer surfaces of the strands. Two good lubricants for this purpose are raw linseed oil and a medium graphite grease. Raw linseed oil dries and is not greasy to handle. Graphite grease is highly resistant to saltwater corrosion. Of course, other commercial lubricants may be obtained and used. One of the best is a semiplastic compound that is thinned by heating before being applied. It penetrates while hot, then cools to a plastic filler, preventing the entrance of water.

One method of applying the lubricant is by using a brush. In doing so, remember to apply the coating of fresh lubricant evenly and to work it in well. Another method involves passing the wire rope through a trough or box containing hot lubricant (figure 4-13). In this method, the heated lubricant is placed in the trough, and the rope passed over a sheave, through the lubricant, and under a second sheave. Hot oils or greases have very good penetrating qualities. Upon cooling, they have high adhesive and film strength around each wire.

As a safety precaution, always wipe off any excess when lubricating wire rope. This is especially important where heavy equipment is involved. Too much lubricant can get on brakes or clutches, causing them to fail. While in use, the motion of machinery

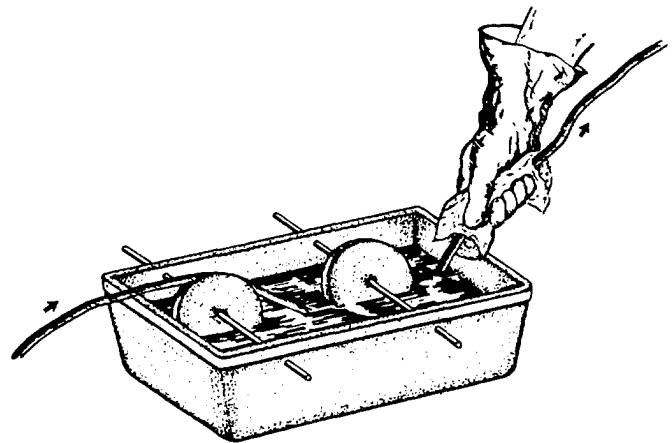

Figure 4-13.—Trough method of lubrication.

can throw excess oil onto crane cabs and catwalks, making them unsafe to work on.

## Storage

Wire rope should not be stored in places where acid is or has been kept. The slightest trace of acid coming in contact with wire rope damages it at that particular spot. Many times, wire rope that has failed has been found to be acid damaged. The importance of keeping acid or acid fumes away from wire rope must be stressed to all hands.

It is especially important that wire rope be cleaned and lubricated properly before it is placed in storage. Fortunately, corrosion of wire rope during storage can be virtually eliminated if the lubricant film is applied properly beforehand and if adequate protection is provided from the weather. Bear in mind that rust, corrosion of wires, and deterioration of the fiber core greatly reduce the strength of wire rope. It is not possible to state exactly the loss of strength that results from these effects. It is certainly great enough to require close observance of those precautions prescribed for protection against such effects.

## Inspection

Wire rope should be inspected at regular intervals, the same as fiber line. In determining the frequency of inspection, you need to carefully consider the amount of use of the rope and conditions under which it is used.

During an inspection, the rope should be examined carefully for fishhooks, kinks, and worn, corroded spots. Usually, breaks in individual wires are concentrated in those portions of the rope that consistently run over the sheaves or bend onto the drum. Abrasion or reverse and sharp bends cause individual wires to break and bend back. The breaks are known as fishhooks. When wires are only slightly worn, but have broken off squarely and stick out all over the rope, the condition is usually caused by overloading or rough handling. Even if the breaks are confined to only one or two strands, the strength of the rope may be seriously reduced. When 4 percent of the total number of wires in the rope are found to have breaks within the length of one lay of the rope, the wire rope is unsafe. Consider a rope unsafe when three broken wires are found in one strand of 6-by-7 rope, six broken wires in one strand of 6-by-19 rope, or nine broken wires in one strand of 6-by-37 rope.

Overloading a rope also causes its diameter to be reduced. Failure to lubricate the rope is another cause of reduced diameter since the fiber core will dry out and eventually collapse or shrink. The surrounding strands are thus deprived of support, and the rope's strength and dependability are correspondingly reduced. Rope that has its diameter reduced to less than 75 percent of its original diameter should be removed from service.

A wire rope should also be removed from service when an inspection reveals widespread corrosion and pitting of the wires. Particular attention should be given to signs of corrosion and rust in the valleys or small spaces between the strands. Since such corrosion is usually the result of improper or infrequent lubrication, the internal wires of the rope are then subject to extreme friction and wear. This form of internal, and often invisible, destruction of the wire is one of the most frequent causes of unexpected and sudden failure of wire rope. The best safeguard, of course, is to keep the rope well lubricated and to handle and store it properly.

## WIRE ROPE ATTACHMENTS

Many attachments can be fitted to the ends of wire rope so that the rope can be connected to other wire ropes, pad eyes, or equipment. The attachment used most often to attach dead ends of wire ropes to pad eyes or like fittings on earthmoving rigs is the wedge socket shown in figure 4-14. The socket is applied to the bitter end of the wire rope, as shown in the figure.

Remove the pin and knock out the wedge first. Then, pass the wire rope up through the socket and

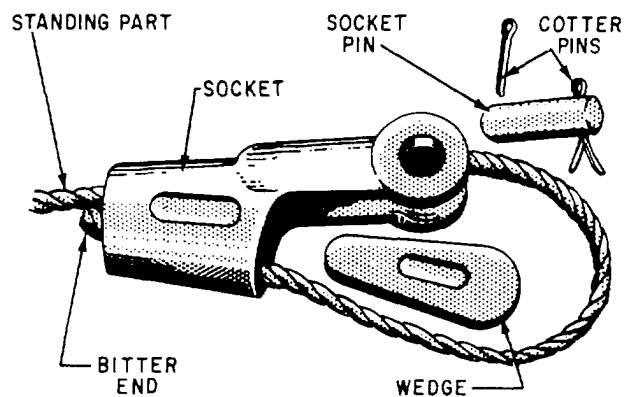

Figure 4-14.—Parts of a wedge socket.

lead enough of it back through the socket to allow a minimum of 6 to 9 inches of the bitter end to extend below the socket. Next, replace the wedge, and haul on the bitter end of the wire rope until the bight closes around the wedge, as shown in figure 4-15. A strain on the standing part will tighten the wedge. You need at least 6 to 9 inches on the dead end (the end of the line that doesn't carry the load). Finally, place one wire rope clip on the dead end to keep it from accidentally slipping back through the wedge socket. The clip should be approximately 3 inches from the socket. Use one size smaller clip than normal so that the threads on the U-bolt are only long enough to clamp tightly on one strand of wire rope. The other alternative is to use the normal size clip and hop the dead end back as shown in figure 4-15. Never attach the clip to the live end of the wire rope.

The advantage of the wedge socket is that it is easy to remove; just take off the wire clip and drive out the wedge. The disadvantage of the wedge socket is that it reduces the strength of wire rope by about 30 percent. Of course, reduced strength means less safe working load.

To make an eye in the end of a wire rope, use new wire rope clips, like those shown in figure 4-16. The U-shaped part of the clip with the threaded ends is called the U-bolt; the other part is called the saddle. The saddle is stamped with the diameter of the wire rope that the clip will fit. Always place a clip with the U-bolt on the bitter end, not on the standing part of the wire rope. If clips are attached incorrectly, the standing part (live end) of the wire rope will be distorted or have mashed spots. An easy way to remember is never saddle a dead horse.

You also need to determine the correct number of clips to use and the correct spacing. Here are two simple formulas.

$$3 \times \text{wire rope diameter} + 1 = \text{number of clips}$$

$$6 \times \text{wire rope diameter} = \text{spacing between clips}$$

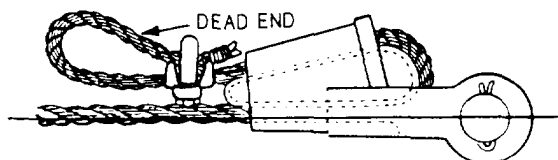

Figure 4-15.—Wedge socket attached properly.

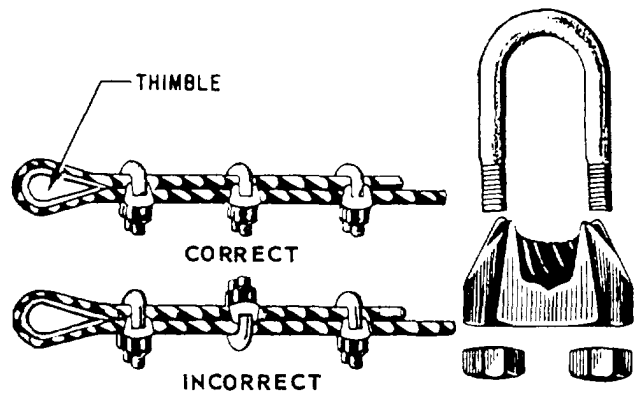

Figure 4-16.—Wire rope clips.

Another type of wire rope clip is the twin-base clip (sometimes referred to as the "universal" or "two-clamp") shown in figure 4-17. Since both parts of this clip are shaped to fit the wire rope, correct installation is almost certain. This considerably reduces potential damage to the rope. The twin-base clip also allows for a clean 360° swing with the wrench when the nuts are being tightened. When an eye is made in a wire rope, a metal fitting (called a thimble) is usually placed in the eye, as shown in figure 4-16, to protect the eye against wear. Clipped eyes with thimbles hold approximately 80 percent of the wire rope strength.

After the eye made with clips has been strained, the nuts on the clips must be retightened. Occasional checks should be made for tightness or damage to the rope caused by the clips.

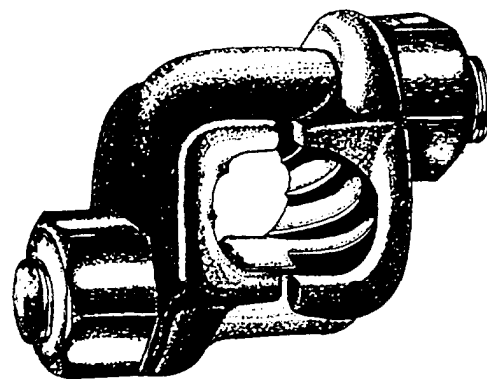

Figure 4-17.—Twin-base wire clip.

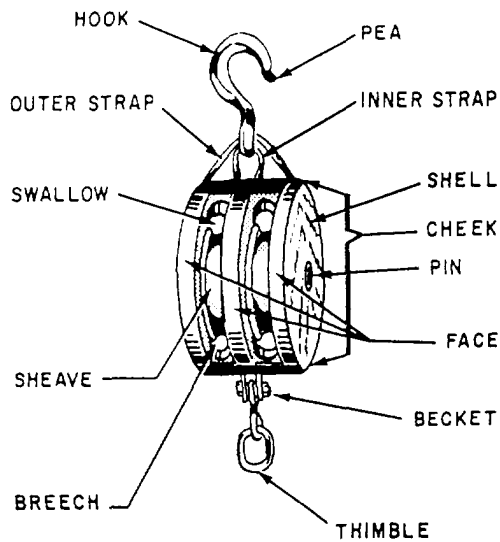

Figure 4-18.—Nomenclature of a fiber line block.

### BLOCK AND TACKLE

*LEARNING OBJECTIVE: Upon completing this section, you should be able to identify the components and operating characteristics of block and tackle units.*

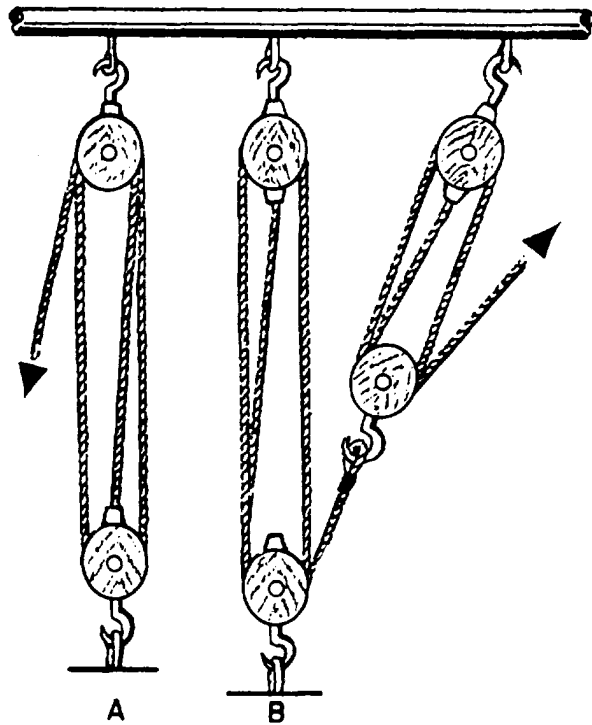

Figure 4-19.—Types of tackle: simple (view A) and compound (view B).

A block (figure 4-18) consists of one or more sheaves fitted in a wood or metal frame supported by a shackle inserted in the strap of the block. A tackle (figure 4-19) is an assembly of blocks and lines used to gain a mechanical advantage in lifting and pulling.

In a tackle assembly, the line is reeved over the sheave(s) of blocks. The two types of tackle systems are simple and compound. A simple tackle system is an assembly of blocks in which a single line is used (view A of figure 4-19). A compound tackle system is an assembly of blocks in which more than one line is used (view B of figure 4-19).

### TACKLE TERMS

To help avoid confusion in working with tackle, you need a working knowledge of tackle vocabulary. Figure 4-20 will help you organize the various terms.

A fall is a line, either a fiber line or a wire rope, reeved through a pair of blocks to form a tackle. The hauling part is the part of the fall leading from one of the blocks upon which the power is exerted. The standing part is the end of the fall, which is attached to one of the becket. The movable (or running) block of a tackle is the block attached to the object to be moved. The fixed (or standing) block is the block attached to a fixed object or support. When a tackle is being used, the movable block moves, and the fixed

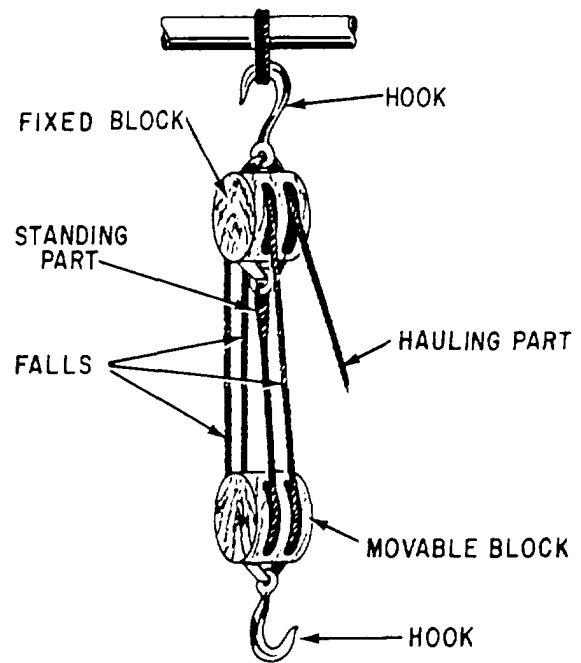

Figure 4-20.—Parts of a tackle.

block remains stationary. The term “two-blocked” means that both blocks of a tackle are as close together as they will go. You may also hear this term called block-and-block. To overhaul is to lengthen a tackle by pulling the two blocks apart. To round in means to bring the blocks of a tackle toward each other, usually without a load on the tackle (opposite of overhaul).

Don't be surprised if your coworkers use a number of different terms for a tackle. For example, line-and-blocks, purchase, and block-and-falls are typical of other names frequently used for tackle.

### BLOCK NOMENCLATURE

The block (or blocks) in a tackle assembly changes (or change) the direction of pull or mechanical advantage, or both. The name and location of the key parts of a fiber line block are shown in figure 4-18.

The frame (or shell), made of wood or metal, houses the sheaves. The sheave is a round, grooved wheel over which the line runs. Ordinarily, blocks used in your work will have one, two, three, or four sheaves. Blocks come with more than this number of sheaves; some come with 11 sheaves. The cheeks are the solid sides of the frame, or shell. The pin is a metal axle that the sheave turns on. It runs from cheek to cheek through the middle of the sheave. The becket is a metal loop formed at one or both ends of a block; the standing part of the line is fastened to this part. The straps hold the block together and support the pin on which the sheaves rotate. The swallow is the opening in the block through which the line passes. The breech is the part of the block opposite the swallow.

### CONSTRUCTION OF BLOCKS

Blocks are constructed for use with fiber line or wire rope. Wire rope blocks are heavily constructed and have a large sheave with a deep groove. Fiber line blocks are generally not as heavily constructed as wire rope blocks and have smaller sheaves with shallower wide grooves. A large sheave is needed with wire rope to prevent sharp bending. Since fiber line is more flexible and pliable than wire rope, it does not require a sheave as large as the same size of wire rope.

Blocks fitted with one, two, three, or four sheaves are often referred to as single, double, triple, and quadruple blocks, respectively. Blocks are fitted with

a number of attachments, the number depending upon their use. Some of the most commonly used fittings are hooks, shackles, eyes, and rings. Figure 4-21 shows two metal frame, heavy-duty blocks. Block A is designed for manila line, and block B is for wire rope.

### RATIO OF BLOCK SIZE TO LINE OR WIRE SIZE

The size of fiber line blocks is designated by the length in inches of the shell or cheek. The size of standard wire rope blocks is controlled by the diameter of the rope. With nonstandard and special-purpose wire rope blocks, the size is found by measuring the diameter of one of its sheaves in inches.

Use care in selecting the proper size line or wire for the block to be used. If a fiber line is reeved onto a tackle whose sheaves are below a certain minimum diameter, the line will be distorted and will soon wear badly. A wire rope too large for a sheave tends to be pinched and damages the sheave. The wire will also be damaged due to the too short a radius of the bend. A wire rope too small for a sheave lacks the necessary bearing surface, puts the strain on only a few strands, and shortens the life of the wire.

With fiber line, the length of the block used should be about three times the circumference of the

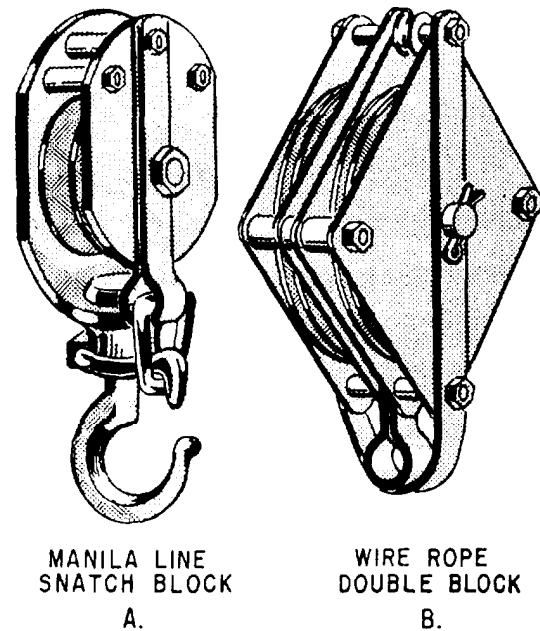

Figure 4-21.—Metal frame, heavy-duty blocks.

line. However, an inch or so either way doesn't matter too much; for example, a 3-inch line may be reeved onto an 8-inch block with no ill effects. As a rule, you are more likely to know the block size than the sheave diameter. However, the sheave diameter should be about twice the size of the circumference of the line used.

Wire rope manufacturers issue tables that give the proper sheave diameters used with the various types and sizes of wire rope they manufacture. In the absence of these, a rough rule of thumb is that the sheave diameter should be about 20 times the diameter of the wire. Remember that with wire rope, it is diameter rather than circumference that is important. Also, remember that this rule refers to the diameter of the sheave rather than to the size of the block.

### SNATCH BLOCKS AND FAIRLEADS

A snatch block (figure 4-22) is a single-sheave block made so that the shell opens on one side at the base of the hook to permit a rope or line to be slipped over a sheave without threading the end of it through the block. Snatch blocks ordinarily are used where it

is necessary to change the direction of the pull on a line.

Figure 4-23 shows a system of moving a heavy object horizontally away from the power source using snatch blocks. This is an ideal way to move objects in limited spaces. Note that the weight is pulled by a single luff tackle, which has a mechanical advantage of 3 (mechanical advantage is discussed below). Adding snatch blocks to a rigging changes the direction of pull, but the mechanical advantage is not affected. It is, therefore, wise to select the proper rigging system to be used based upon the weight of the object and the type and capacity of the power that is available.

The snatch block that is used as the last block in the direction of pull to the power source is called the leading block. This block can be placed in any convenient location provided it is within 20 drum widths of the power source. This is required because the fairlead angle, or fleet angle, cannot exceed  $2^\circ$  from the center line of the drum; therefore, the 20-drum width distance from the power source to the leading block will assure the fairlead angle. If the fairlead angle is not maintained, the line could jump the sheave of the leading block and cause the line on the reel to jump a riding turn.

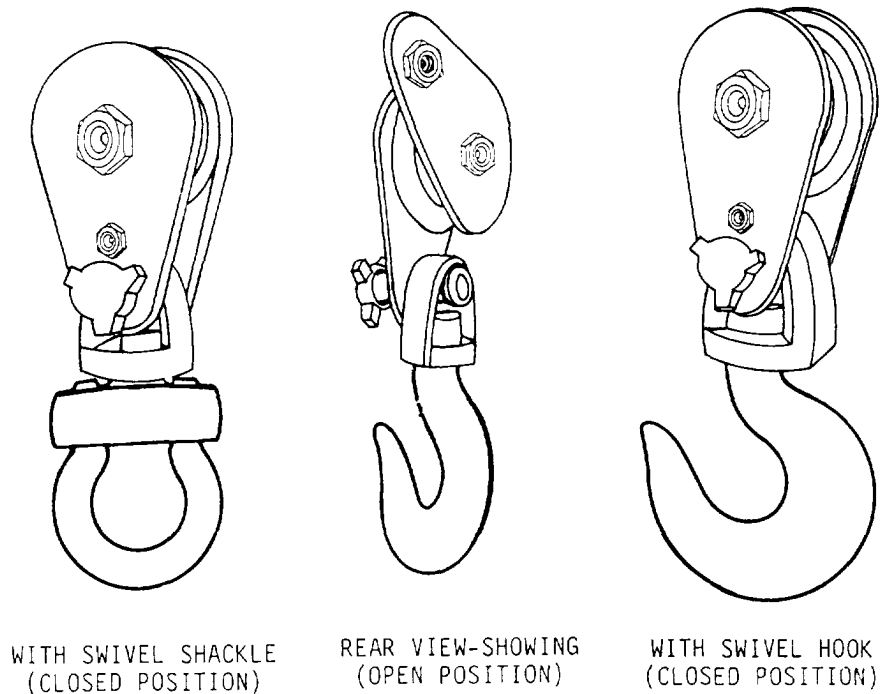

Figure 4-22.—Top dead end snatch blocks.

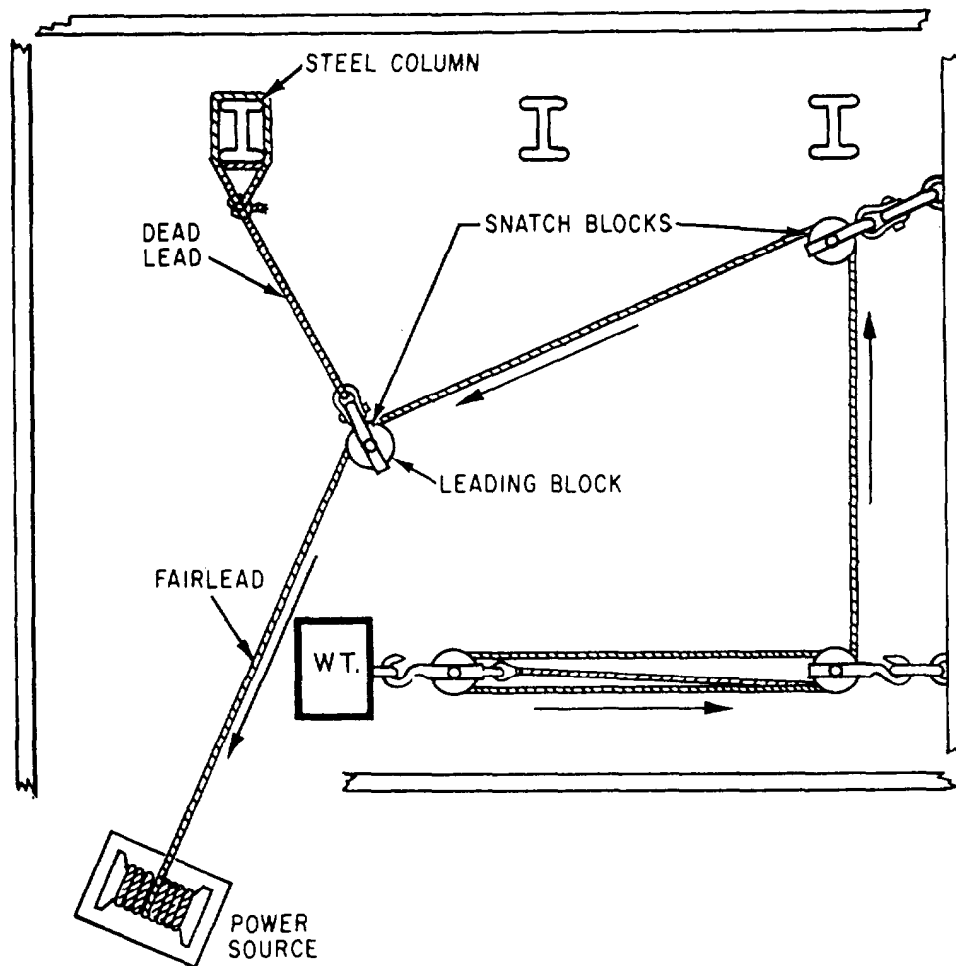

Figure 4-23.—Moving a heavy object horizontally along a floor with limited access using snatch blocks and fairleads.

### MECHANICAL ADVANTAGE

The mechanical advantage of a tackle is the term applied to the relationship between the load being lifted and the power required to lift it. If the load and the power required to lift it are the same, the mechanical advantage is 1. However, if a load of 50 pounds requires only 10 pounds to lift it, then you have a mechanical advantage of 5 to 1, or 5 units of weight are lifted for each unit of power applied.

The easiest way to determine the mechanical advantage of a tackle is by counting the number of parts of the falls at the running block. If there are two parts, the mechanical advantage is two times the power applied (disregarding friction). A gun tackle, for instance, has a mechanical advantage of 2. Therefore, lifting a 200-pound load with a gun tackle requires 100 pounds of power, disregarding friction.

To determine the amount of power required to lift a given load by means of a tackle, determine the weight of the load to be lifted and divide that by the mechanical advantage. For example, if it is necessary to lift a 600-pound load by means of a single luff tackle, first determine the mechanical advantage gained by the tackle. By counting the parts of the falls at the movable block, you determine a mechanical advantage of 3. By dividing the weight to be lifted, 600 pounds, by the mechanical advantage in this tackle, 3, we find that 200 pounds of power is required to lift a weight of 600 pounds using a single luff tackle.

Remember though, a certain amount of the force applied to a tackle is lost through friction. Friction develops in a tackle by the lines rubbing against each other, or against the shell of a block. Therefore, an adequate allowance for the loss from friction must be added. Roughly, 10 percent of the load must be allowed for each sheave in the tackle.

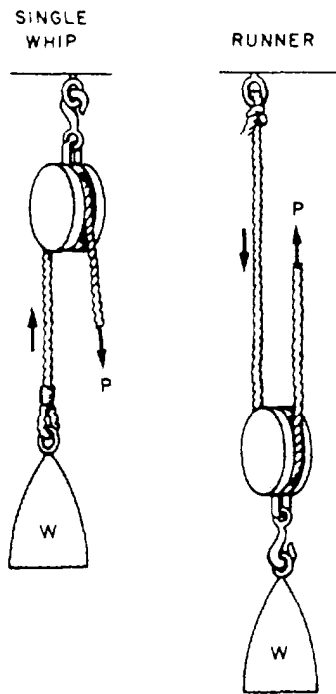

Figure 4-24.—Single-whip and runner tackle.

## TYPES OF TACKLE

Tackles are designated in two ways: first, according to the number of sheaves in the blocks that are used to make the tackle, such as single whip or twofold purchase; and second, by the purpose for which the tackle is used, such as yard tackles or stay

tackles. In this section, we'll discuss some of the different types of tackle in common use: namely, single whip, runner, gun tackle, single luff, twofold purchase, double luff, and threefold purchase. Before proceeding, we should point out that the purpose of the letters and arrows in figures 4-24 through 4-30 is to indicate the sequence and direction in which the standing part of the fall is led in reeving. You may want to refer to these illustrations when we discuss reeving of blocks in the next sections.

A single-whip tackle consists of one single-sheave block (tail block) fixed to a support with a rope passing over the sheave (figure 4-24.) It has a mechanical advantage of 1. If a 100-pound load is lifted, a pull of 100 pounds, plus an allowance for friction, is required.

A runner (figure 4-24) is a single-sheave movable block that is free to move along the line on which it is reeved. It has a mechanical advantage of 2.

A gun tackle is made up of two single-sheave blocks (figure 4-25). This tackle got its name in the old days because it was used to haul muzzle-loading guns back into the battery after the guns had been fired and reloaded. A gun tackle has a mechanical advantage of 2. To lift a 200-pound load with a gun tackle requires 100 pounds of power, disregarding friction.

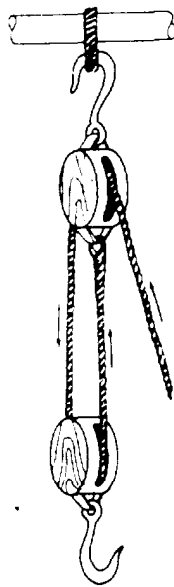

Figure 4-25.—Gun tackle.

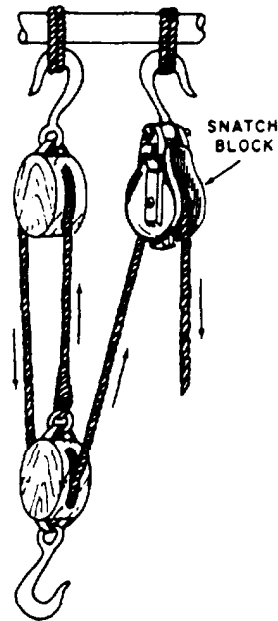

Figure 4-26.—Inverted gun tackle.



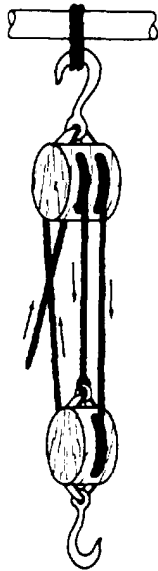

Figure 4-27.—Single-luff tackle.

By inverting any tackle, you always gain a mechanical advantage of 1 because the number of parts at the movable block is increased. By inverting a gun tackle, for example, you gain a mechanical advantage of 3 (figure 4-26). When a tackle is inverted, the direction of pull is difficult. This can easily be overcome by adding a snatch block, which

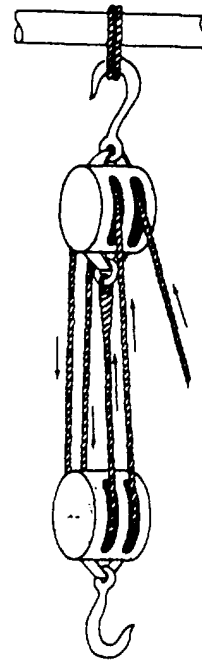

Figure 4-29.—Twofold purchase.

changes the direction of the pull, but does not increase the mechanical advantage.

A single-luff tackle consists of a double and single block as indicated in figure 4-27, and the double-luff tackle has one triple and one double

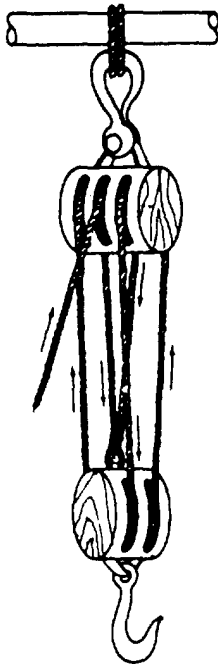

Figure 4-28.—Double-luff tackle.

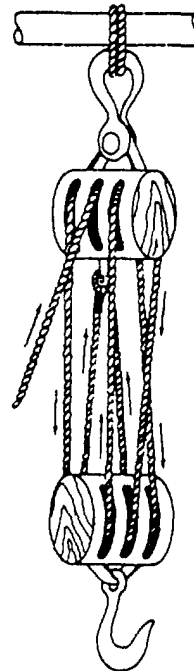

Figure 4-30.—Threefold purchase.

block, as shown in figure 4-28. The mechanical advantage of the single is 3, whereas the mechanical advantage of the double is 5.

A twofold purchase consists of two double blocks, as shown in figure 4-29, whereas a threefold purchase consists of two triple blocks, as shown in figure 4-30. The mechanical advantage of the twofold purchase is 4; the advantage of the threefold is 6.

### REEVING TACKLE

In reeving a simple tackle, lay the blocks a few feet apart. The blocks should be placed down with the sheaves at right angles to each other and the becket ends pointing toward each other.

To begin reeving, lead the standing part of the falls through one sheave of the block that has the greatest number of sheaves. If both blocks have the same number of sheaves, begin at the block fitted with the becket. Then, pass the standing part around the sheaves from one block to the other, making sure no lines are crossed, until all sheaves have a line passing over them. Now, secure the standing part of the falls at the becket of the block containing the least number of sheaves, using a becket hitch for a temporary securing or an eye splice for a permanent securing.

With blocks of more than two sheaves, the standing part of the falls should be led through the sheave nearest the center of the block. This method places the strain on the center of the block and prevents the block from toppling and the lines from being cut by rubbing against the edges of the block.

Falls are generally reeved through 8- or 10-inch wood or metal blocks in such a reamer as to have the lower block at right angles to the upper block. Two, three-sheave blocks are the usual arrangement, and the method of reeving these is shown in figure 4-31. The hauling part must go through the middle sheave of the upper block, or the block will tilt to the side and the falls jam when a strain is taken.

If a three- and two-sheave block rig is used, the method of reeving is about the same (figure 4-32), but, in this case, the becket for the dead end must be on the lower, rather than the upper, block.

Naturally, you must reeve the blocks before you splice in the becket thimble, or you will have to reeve the entire fall through from the opposite end.

### SAFE WORKING LOAD OF A TACKLE

You know that the force applied at the hauling part of a tackle is multiplied as many times as there

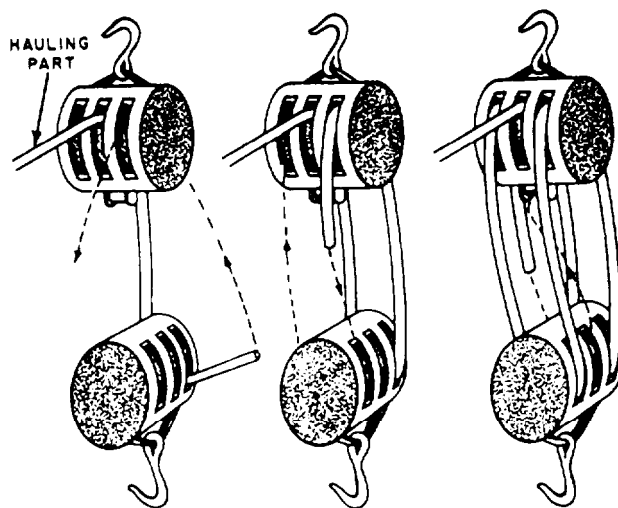

Figure 4-31.—Reeving a threefold purchase.

are parts of the fall on the movable block. Also, an allowance for friction must be made, which adds roughly 10 percent to the weight to be lifted for every sheave in the system. For example, if you are lifting a weight of 100 pounds with a tackle containing five sheaves, you must add 10 percent times 5, or 50 percent, of 100 pounds to the weight in your calculations. In other words, you determine that this tackle is going to lift 150 pounds instead of 100 pounds.

Disregarding friction, the safe working load of a tackle should be equal to the safe working load of the line or wire used, multiplied by the number of parts of the fall on the movable block. To make the necessary

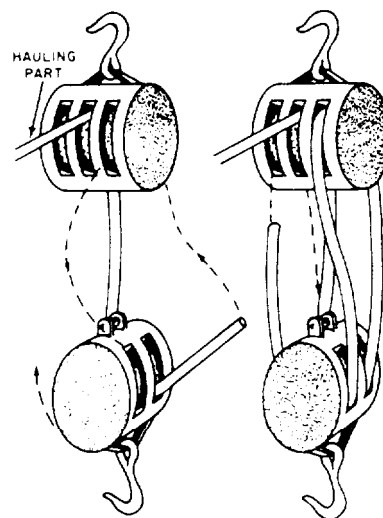

Figure 4-32.—Reeving a double-luff tackle.

allowance for friction, you multiply this result by 10, and then divide what you get by 10 plus the number of sheaves in the system.

Suppose you have a threefold purchase, a mechanical advantage of 6, reeved with a line that has a safe working load of 2 tons. Disregarding friction, 6 times 2, or 12 tons, should be the safe working load of this setup. To make the necessary allowance for friction, however, you first multiply 12 by 10, which gives you 120. This you divide by 10 plus 6 (number of sheaves in a threefold purchase), or 16. The answer is 7 1/2 tons safe working load.

### Lifting a Given Weight

To find the size of **fiber** line required to lift a given load, use this formula:

$$C \text{ (in inches)} = \sqrt{15 \times P \text{ (tons)}}$$

*C* in the formula is the circumference, in inches, of the line that is safe to use. The number 15 is the conversion factor. *P* is the weight of the given load expressed in tons. The radical sign, or symbol, over  $15 \times P$  indicates that you are to find the square root of that product.

To square a number means to multiply that number by itself. Finding the square root of a number simply means finding the number that, multiplied by itself, gives the number whose square root you are seeking. Most pocket calculators today have the square root function. Now, let's determine what size fiber line you need to hoist a 5-ton load. First, circumference equals 15 times five, or  $C = 15 \times 5$ , or 75. Next, the number that multiplied by itself comes nearest to 75 is 8.6. Therefore, a fiber line 8 1/2 inches in circumference will do the job.

The formula for finding the size of **wire** rope required to lift a given load is:  $C \text{ (in inches)} = 2.5 \times P \text{ (tons)}$ . You work this formula in the same manner explained above for fiber line. One point you should be careful not to overlook is that these formulas call for the circumference of the wire. You are used to talking about wire rope in terms of its diameter, so remember that circumference is about three times the diameter, roughly speaking. You can also determine circumference by the following formula, which is more accurate than the rule of thumb: circumference equals diameter times pi ( $\pi$ ). In using this formula, remember that  $\pi$  equals approximately 3.14.

### Size of Line to Use in a Tackle

To find the size of line to use in a tackle for a given load, add one-tenth (10 percent for friction) of its value to the weight to be hoisted for every sheave in the system. Divide the result you get by the number of parts of the fall at the movable block, and use this result as *P* in the formula

$$C = \sqrt{15 \times P}$$

For example, let's say you are trying to find the size of fiber line to reeve in a threefold block to lift 10 tons. There are six sheaves in a threefold block. Ten tons plus one-tenth for each of the six sheaves (a total of 6 tons) gives you a theoretical weight of 16 tons to be lifted. Divide 16 tons by 6 (number of parts on the movable block in a threefold block), and you get about 2 2/3. Using this as *P* in the formula you get

$$C = \sqrt{15 \times 2 \frac{2}{3}} \text{ or } \sqrt{40} \text{ or about } 6.3$$

The square root of 40 is about 6.3, so it will take a line of about 6 1/2 inches in this purchase to hoist 10 tons safely. As you seldom find three-sheave blocks that will take a line as large as 6 1/2 inches, you will probably have to rig two threefold blocks with a continuous fall, as shown in figure 4-33. Each of

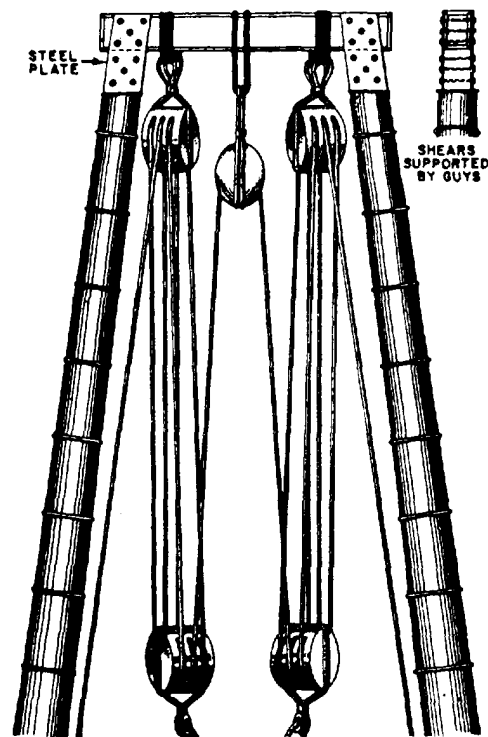

Figure 4-33.—Rigging two tackles with continuous fall.

these will have half of the load. To find the size of the line to use, calculate what size fiber line in a threefold block will lift 5 tons. It works out to about 4 1/2 inches.

## TACKLE SAFETY PRECAUTIONS

In hoisting and moving heavy objects with blocks and tackle, stress safety for people and materials.

Always check the condition of blocks and sheaves before using them on a job to make sure they are in safe working order. See that the blocks are properly greased. Also, make sure that the line and sheave are the right size for the job.

Remember that sheaves or drums that have become worn, chipped, or corrugated must not be used because they will damage the line. Always find out whether you have enough mechanical advantage in the amount of blocks to make the load as easy to handle as possible.

Sheaves and blocks designed for use with fiber line must not be used for wire rope since they are not strong enough for that service, and the wire rope does not fit the sheave grooves. Also, sheaves and blocks built for wire rope should never be used for fiber line.

## HOOKS AND SHACKLES

Hooks and shackles are handy for hauling or lifting loads without tying them directly to the object with a line or wire rope. They can be attached to wire rope, fiber line, or blocks. Shackles should be used for loads too heavy for hooks to handle.

Hooks should be inspected at the beginning of each workday and before lifting a full-rated load. Figure 4-34, view A, shows where to inspect a hook for wear and strain. Be especially careful during the inspection to look for cracks in the saddle section and at the neck of the hook.

When the load is too heavy for you to use a hook, use a shackle. Shackles, like hooks, should be inspected on a daily routine and before lifting heavy loads. Figure 4-34, view B, shows the area to look for wear.

You should never replace the shackle pin with a bolt. Never use a shackle with a bent pin, and never allow the shackle to be pulled at an angle; doing so will reduce its carrying capacity. Packing the pin with washers centralizes the shackle (figure 4-34, view B).

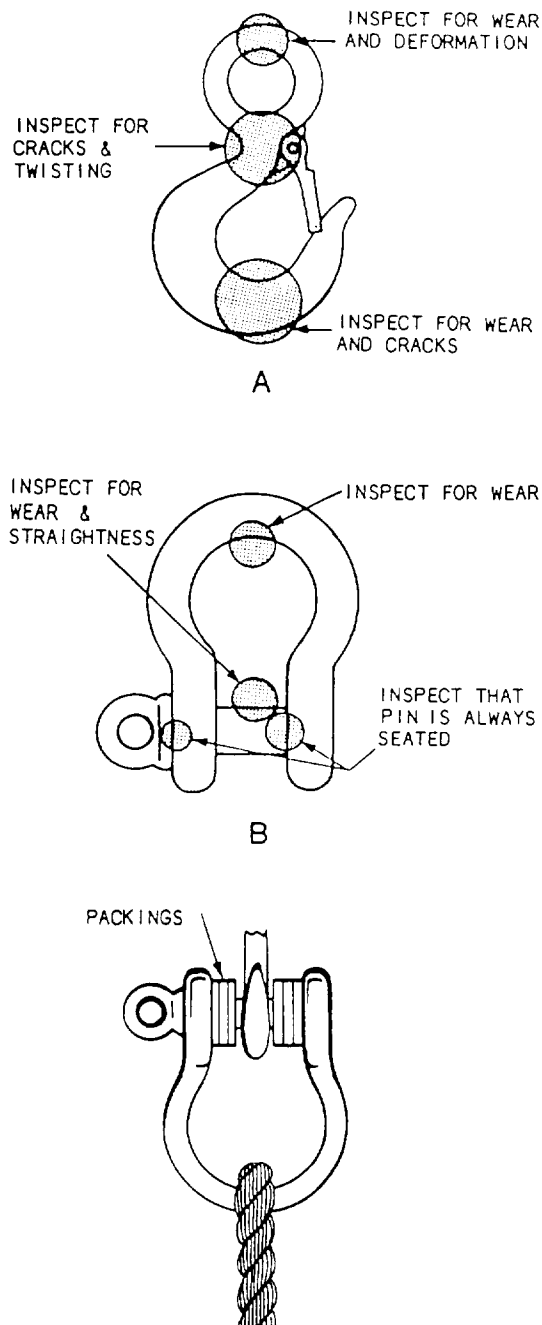

Figure 4-34.—Hook and shackle inspection (views A and B) and packing a shackle with washers.

If you need a hook or shackle for a job, always get it from Alfa Company. This way, you will know that it has been load tested.

Mousing is a technique often used to close the open section of a hook to keep slings, straps, and so on, from slipping off the hook (figure 4-35). To some extent, it also helps prevent straightening of the hook. Hooks may be moused with rope yarn, seizing wire, or a shackle. When using rope yarn or wire, make 8

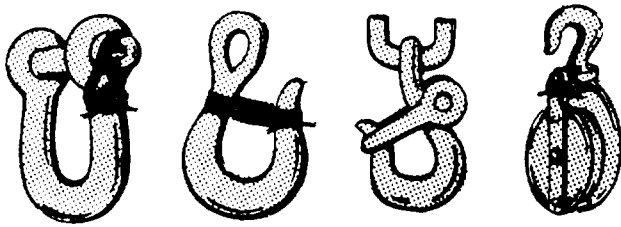

Figure 4-35.—Mousing.

or 10 wraps around both sides of the hook. To finish off, make several turns with the yarn or wire around the sides of the mousing, and then tie the ends securely (figure 4-35).

Shackles are moused when there is danger of the shackle pin working loose and coming out because of vibration. To mouse a shackle, simply take several turns with seizing wire through the eye of the pin and around the bow of the shackle. Figure 4-35 shows what a properly moused shackle looks like.

## HOISTING

*LEARNING OBJECTIVE: Upon completing this section, you should have a basic understanding of hoisting, handsignals used in lifting loads, and some of the safety rules of lifting.*

In lifting any load, it takes two personnel to ensure a safe lift: an equipment operator and a signalman. In the following paragraphs, we will discuss the importance of the signalman and a few of the safety rules to be observed by all hands engaged in hooking on.

## SIGNALMAN

One person, and one person only, should be designated as the official signalman for the operator of a piece of hoisting equipment, and both the signalman and the operator must be thoroughly familiar with the standard hand signals. When possible, the signalman should wear some distinctive article of dress, such as a bright-colored helmet. The signalman must maintain a position from which the load and the crew working on it can be seen, and also where he can be seen by the operator.

Appendix III at the end of this TRAMAN shows the standard hand signals for hoisting equipment. Some of the signals shown apply only to mobile

equipment; others, to equipment with a boom that can be raised, lowered, and swung in a circle. The two-arm hoist and lower signals are used when the signalman desires to control the speed of hoisting or lowering. The one-arm **hoist** or **lower** signal allows the operator raise or lower the load. To dog off the load and boom means to set the brakes so as to lock both the hoisting mechanism and the boom hoist mechanism. The signal is given when circumstances require that the load be left hanging motionless.

With the exception of the emergency stop signal, which may be given by anyone who sees a necessity for it, and which must be obeyed instantly by the operator, only the official signalman gives the signals. The signalman is responsible for making sure that members of the crew remove their hands from slings, hooks, and loads before giving a signal. The signalman should also make sure that all persons are clear of bights and snatch block lines.

## ATTACHING A LOAD

The most common way of attaching a load to a lifting hook is to put a sling around the load and hang the sling on the hook (figure 4-36). A sling can be made of line, wire, or wire rope with an eye in each

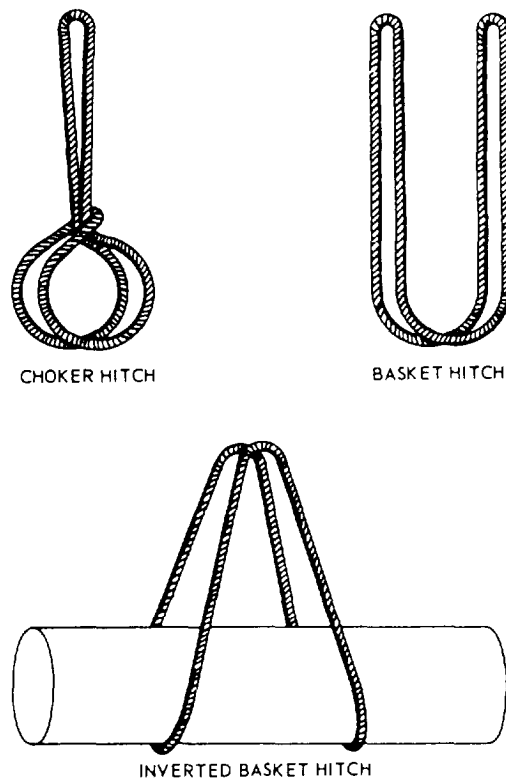

Figure 4-36.—Ways of hitching on a sling.

end (also called a strap) or an endless sling (figure 4-37). When a sling is passed through its own bight or eye, or shackled or hooked to its own standing part, so that it tightens around the load like a lasso when the load is lifted, the sling is said to be choked, or it may be called a choker, as shown in figures 4-36 and 4-37. A two-legged sling that supports the load at two points is called a bridle, as shown in figure 4-38.

### SAFETY RULES

The following safety rules must be given to all hands engaged in hooking on. They must be strictly observed.

- The person in charge of hooking on must know the safe working load of the rig and the weight of every load to be hoisted. The hoisting of any load heavier than the safe working load of the rig is absolutely prohibited.
- When a cylindrical metal object, such as a length of pipe, a gas cylinder, or the like, is hoisted in a choker bridle, each leg of the bridle should be given a round turn around the load before it is hooked or shackled to its own part or have a spreader bar placed between the legs. The purpose of this is to ensure that the legs of the bridle will not slide together along the load, thereby upsetting the balance and possibly dumping the load.
- The point of strain on a hook must never be at or near the point of the hook.
- Before the hoist signal is given, the person in charge must be sure that the load will balance evenly in the sling.

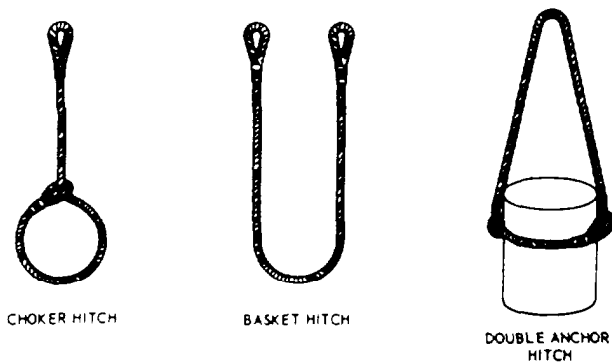

Figure 4-37.—Ways of hitching on straps.

- Before the hoist signal is given, the person in charge should be sure that the lead of the whip or falls is vertical. If it is not, the load will take a swing as it leaves the deck or ground.
- As the load leaves the deck or ground, the person in charge must watch carefully for kinked or fouled falls or slings. If any are observed, the load must be lowered at once for clearing.
- Tag lines must be used to guide and steady a load when there is a possibility that the load might get out of control.
- Before any load is hoisted, it must be inspected carefully for loose parts or objects that might drop as the load goes up.
- All personnel must be cleared from and kept out of any area that is under a suspended load, or over which a suspended load may pass.
- Never walk or run under a suspended load.
- Loads must not be placed and left at any point closer than 4 feet 8 inches from the nearest rail

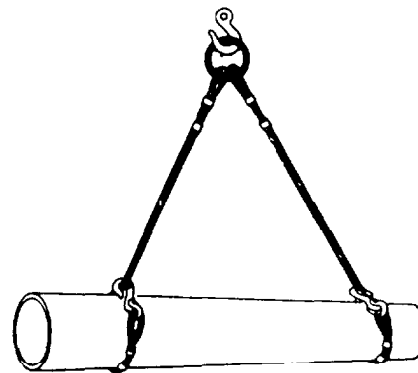

Figure 4-38.—Bridles.

of a railroad track or crane truck, or in any position where they would impede or prevent access to fire-fighting equipment.

- When materials are being loaded or unloaded from any vehicle by crane, the vehicle operators and all other persons, except the rigging crew, should stand clear.
- When materials are placed in work or storage areas, dunnage or shoring must be provided, as necessary, to prevent tipping of the load or shifting of the materials.
- All crew members must stand clear of loads that tend to spread out when landed.
- When slings are being heaved out from under a load, all crew members must stand clear to avoid a backlash, and also to avoid a toppling or a tip of the load, which might be caused by fouling of a sling.

## SHEAR LEGS

The shear legs are formed by crossing two timbers, poles, planks, pipes, or steel bars and lashing or bolting them together near the top. A sling is suspended from the lashed intersection and is used as a means of supporting the load tackle system (figure 4-39). In addition to the name shear legs, this rig often is referred to simply as a “shears”. (It has also been called an A-frame.)

The shear legs are used to lift heavy machinery and other bulky objects. They may also be used as end supports of a cableway and highline. The fact that the shears can be quickly assembled and erected is a major reason why they are used in field work.

A shears requires only two guy lines and can be used for working at a forward angle. The forward guy does not have much strain imposed on it during hoisting. This guy is used primarily as an aid in adjusting the drift of the shears and in keeping the top of the rig steady in hoisting or placing a load. The after guy is a very important part of the shears' rigging, as it is under considerable strain when hoisting. It should be designed for a strength equal to one-half the load to be lifted. The same principles for thrust on the spars or poles apply; that is, the thrust increases drastically as the shear legs go off the perpendicular.

In rigging the shears, place your two spars on the ground parallel to each other and with their butt ends

even. Next, put a large block of wood under the tops of the legs just below the point of lashing, and place a small block of wood between the tops at the same point to facilitate handling of the lashing. Now, separate the poles a distance equal to about one-third the diameter of one pole.

As lashing material, use 18- or 21-thread small stuff. In applying the lashing, first make a clove hitch around one of the legs. Then, take about eight or nine turns around both legs above the hitch, working towards the top of the legs. Remember to wrap the turns tightly so that the finished lashing will be smooth and free of kinks. To apply the frapping (tight lashings), make two or three turns around the lashing between the legs; then, with a clove hitch, secure the end of the line to the other leg just below the lashing (figure 4-39).

Now, cross the legs of the shears at the top, and separate the butt ends of the two legs so that the spread between them is equal to one-half the height of the shears. Dig shallow holes, about 1 foot (30 cm) deep, at the butt end of each leg. The butts of the legs should be placed in these holes in erecting the shears. Placing the legs in the holes will keep them from kicking out in operations where the shears are at an angle other than vertical.

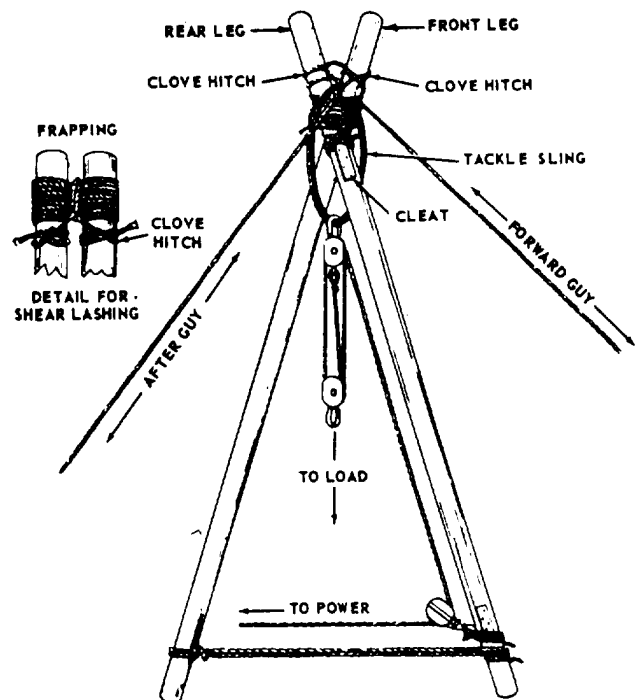

Figure 4-39.—Shear legs.

The next step is to form the sling for the hoisting falls. To do this, take a short length of line, pass it a sufficient number of times over the cross at the top of the shears, and tie the ends together. Then, reeve a set of blocks and place the hook of the upper block through the sling, and secure the hook by mousing the open section of the hook with rope yarn to keep it from slipping off the sling. Fasten a snatch block to the lower part of one of the legs, as indicated in figure 4-39.

The guys—one forward guy and one after guy—are secured next to the top of the shears. Secure the forward guy to the rear leg and the after guy to the front leg using a clove hitch in both instances. If you need to move the load horizontally by moving the head of the shears, you must rig a tackle in the after guy near its anchorage.

### TRIPODS

A tripod consists of three legs of equal length that are lashed together at the top (figure 4-40). The legs are generally made of timber poles or pipes. Materials used for lashing include fiber line, wire rope, and chain. Metal rings joined with short chain sections are also available for insertion over the top of the tripod legs.

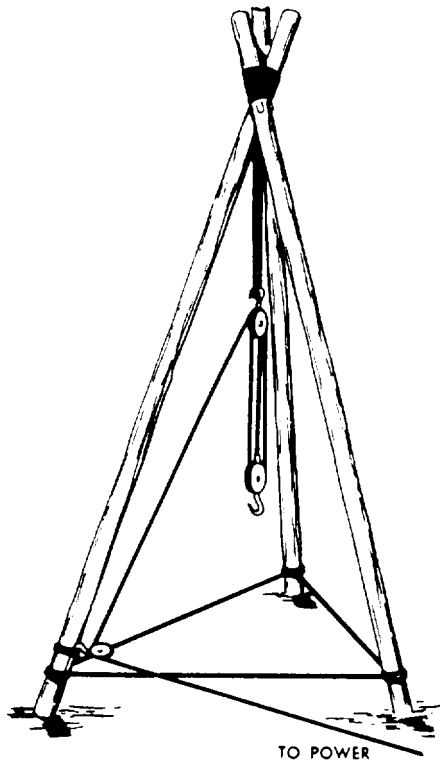

Figure 4-40.—Tripod.

When compared with other hoisting devices, the tripod has a distinct disadvantage: it is limited to hoisting loads only vertically. Its use will be limited primarily to jobs that involve hoisting over wells, mine shafts, or other such excavations. A major advantage of the tripod is its great stability. In addition, it requires no guys or anchorages, and its load capacity is approximately one-third greater than shears made of the same-size timbers. Table 4-1 gives the load-carrying capacities of shear legs and tripods for various pole sizes.

### Rigging Tripods

The strength of a tripod depends largely on the strength of the material used for lashing, as well as the amount of lashing used. The following procedure for

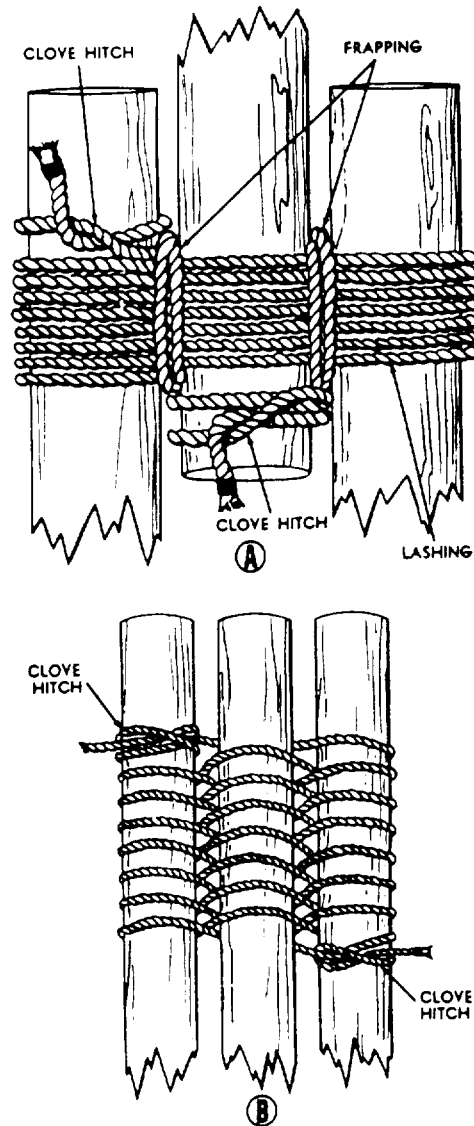

Figure 4-41.—Lashings for a tripod.



Table 4-1.—Load-Carrying Capacities of Shear Legs and Tripods

POLE SIZE (INCHES)	LENGTH (FEET)	WORKING CAPACITY (TONS) SHEAR LEGS (2) POLES	WORKING CAPACITY (TONS) TRIPODS (3) POLES
6 × 6	20	8	13
	25	5	7
	30	3	5
8 × 8	25	12	18
	30	8	13
	40	5	7
	50	3	5
10 × 10	20	35	52
	25	26	39
	30	17	26
	40	10	15
	50	7	10
12 × 12	30	35	52
	40	21	31
	50	14	21
	60	10	15

lashing applies to a line 3 inches in circumference or smaller. For extra heavy loads, use more turns than specified in the procedure given here. For light loads, use fewer turns than specified here.

As the first step of the procedure, take three spars of equal length and place a mark near the top of each to indicate the center of the lashing. Now, lay two of the spars parallel with their tops resting on a skid (or block). Place the third spar between the two, with the butt end resting on a skid. Position the spars so that the lashing marks on all three are in line. Leave an interval between the spars equal to about one-half the diameter of the spars. This will keep the lashing from being drawn too tightly when the tripod is erected.

With the 3-inch line, make a clove hitch around one of the outside spars; put it about 4 inches above the lashing mark. Then, make eight or nine turns with the line around all three spars. (See view A of figure 4-41.) In making the turns, remember to maintain the proper amount of space between the spars.

Now, make one or two close frapping turns around the lashing between each pair of spars. Do not draw the turns too tightly. Finally, secure the end of the line with a clove hitch on the center spar just above the lashing, as shown in view A of figure 4-41.

There is another method of lashing a tripod that you may find preferable to the method just given. It may be used in lashing slender poles up to 20 feet in length, or when some means other than hand power is available for erection,

First, place the three spars parallel to each other, leaving an interval between them slightly greater than twice the diameter of the line to be used. Rest the top of each pole on a skid so that the end projects about 2 feet over the skid. Then, line up the butts of the three spars, as indicated in view B of figure 4-41.

Next, make a clove hitch on one outside leg at the bottom of the position the lashing will occupy, which is about 2 feet from the end. Now, proceed to weave the line over the middle leg, under and around the other outside leg, under the middle leg, over and around the first leg, and so forth, until completing about eight or nine turns. Finish the lashing by forming a clove hitch on the other outside leg (view B of figure 4-41).

#### ERECTING TRIPODS

In the final position of an erected tripod, it is important that the legs be spread an equal distance

apart. The spread between legs must be no more than two-thirds nor less than one-half the length of a leg, Small tripods, or those lashed according to the first procedure given in the preceding section, may be raised by hand. Here are the main steps.

Start by raising the top ends of the three legs about 4 feet, keeping the butt ends of the legs on the ground. Now, cross the tops of the two outer legs, and position the top of the third or center leg so that it rests on top of the cross.

A sling for the hoisting tackle can be attached readily by first passing the sling over the center leg, and then around the two outer legs at the cross. Place the hook of the upper block of a tackle on the sling, and secure the hook by mousing.

The raising operation can now be completed. To raise an ordinary tripod, a crew of about eight maybe required. As the tripod is being lifted, spread the legs so that when it is in the upright position, the legs will be spread the proper distance apart. After getting the tripod in its final position, lash the legs near the bottom with line or chain to keep them from shifting (figure 4-40). Where desirable, a leading block for the hauling part of the tackle can be lashed to one of the tripod legs, as indicated in figure 4-40.

In erecting a large tripod you may need a small gin pole to aid in raising the tripod into position. To erect a tripod lashed according to the first procedure described in the preceding section, you first raise the tops of the legs far enough from the ground to permit spreading them apart. Use guys or tag lines to help hold the legs steady while they are being raised. Now, with the legs clear of the ground, cross the two outer legs and place the center leg so that it rests on top of the cross. Then, attach the sling for the hoisting tackle. Here, as with a small tripod, simply pass the sling over the center leg and then around the two outer legs at the cross.

## SCAFFOLDING

*LEARNING OBJECTIVE: Upon completing this section, you should be able to determine the proper usage of wood and prefabricated metal scaffolding.*

As the working level of a structure rises above the reach of crew members on the ground or deck, temporary elevated platforms, called scaffolding, are

erected to support the crew members, their tools, and materials,

There are two types of scaffolding in use today—wood and prefabricated. The wood types include the swinging scaffold, which is suspended from above, and the pole scaffold, which is supported on the ground or deck. The prefabricated type is made of metal and is put together in sections, as needed.

## SWINGING SCAFFOLD CONSTRUCTION

The simplest type of a swinging scaffold consists of an unspliced plank that is made from 2-by-8-inch (minimum) lumber. Hangers should be placed between 6 and 18 inches from the ends of the plank. The span between hangers should not exceed 10 feet. Make sure that the hangers are secured to the plank to stop them from slipping off. Figure 4-42 shows the construction of a hanger with a guardrail. The guardrail should be made of 2-by-4-inch material between 36- and 42-inches high. A midrail, if required, should be constructed of 1-by-4 lumber.

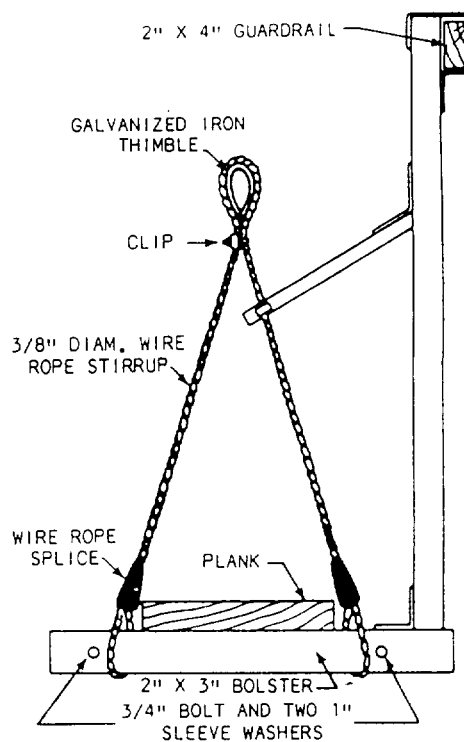

Figure 4-42.—Typical hanger to use with plank scaffold.

Swing scaffolds should be suspended by wire or fiber line secured to the outrigger beams, A minimum safety factor of 6 is required for suspension ropes, The blocks for fiber ropes should be the standard 6-inch size consisting of at least one double block and one single block. The sheaves of all blocks should fit the size of rope used.

The outrigger beams should be spaced no more than the hanger spacing and should be constructed of no less than 2-by-10 lumber. The beam should not extend more than 6 feet beyond the face of the building. The inboard side should be 9 feet beyond the edge of the building and should be securely fastened to the building.

Figure 4-43 shows a swinging scaffold that can be used for heavy work with block and tackle.

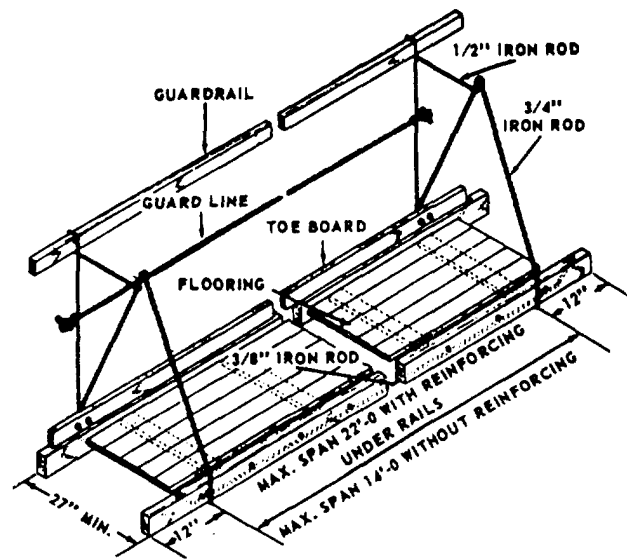

Figure 4-43.—Swinging scaffold.

### POLE SCAFFOLD CONSTRUCTION

The poles on a job-built pole scaffold should not exceed 60 feet in height. If higher poles are required, the scaffolding must be designed by an engineer.

- All poles must be setup perfectly plumb.
- The lower ends of poles must not bear directly on a natural earth surface. If the surface is earth, a board footing 2-inches thick and 6- to 12-inches wide (depending on the softness of the earth) must be placed under the poles.
- If poles must be spliced, splice plates must not be less than 4-feet long, not less than the width of the pole wide, and each pair of plates must have a combined thickness not less than the thickness of the pole. Adjacent poles must not be spliced at the same level.
- A ledger must be long enough to extend over two pole spaces, and it must overlap the poles at the ends by at least 4 inches. Ledgers must be spliced by overlapping and nailing at poles—never between poles. If platform planks are raised as work progresses upward, the ledgers and logs on which the planks previously rested must be left in place to brace and stiffen the poles. For a heavy-duty scaffold, ledgers must be supported by cleats, nailed or bolted to the poles, as well as by being nailed themselves to the poles.
- A single log must be set with the longer section dimension vertical, and logs must be long

enough to overlap the poles by at least 3 inches. They should be both face nailed to the poles and toenailed to the ledgers. When the inner end of the log butts against the wall (as it does in a single-pole scaffold), it must be supported by a 2-by-6-inch bearing block, not less than 12 inches long, notched out the width of the log and securely nailed to the wall. The inner end of the log should be nailed to both the bearing block and the wall. If the inner end of a log is located in a window opening, it must be supported on a stout plank nailed across the opening. If the inner end of a log is nailed to a building stud, it must be supported on a cleat, the same thickness as the log, and nailed to the stud.

- A platform plank must never be less than 2-inches thick. Edges of planks should be close enough together to prevent tools or materials from falling through the opening. A plank must be long enough to extend over three logs, with an overlap of at least 6 inches, but not more than 12 inches.

### PREFABRICATED SCAFFOLD ERECTION

Several types of scaffolding are available for simple and rapid erection, one of which is shown in

figure 4-44. The scaffold uprights are braced with diagonal members, and the working level is covered with a platform of planks. All bracing must form triangles, and the base of each column requires adequate footing plates for bearing area on the ground or deck. The steel scaffolding is usually erected by placing the two uprights on the ground or deck and inserting the diagonal members. The diagonal members have end fittings that permit rapid locking in position. In tiered scaffolding, figure 4-45, the first tier is set on steel bases on the ground, and a second tier is placed in the same manner on the first tier with the bottom of each upright locked to the top of the lower tier. A third and fourth upright can be placed on the ground level and locked to the first set with diagonal bracing. The scaffolding can be built as high as desired, but high scaffolding should be tied to the main structure. Where necessary, scaffolding can be mounted on casters for easy movement.

Prefabricated scaffolding comes in three categories: light, medium, and heavy duty. Light duty has nominal 2-inch-outside-diameter steel-tubing bearers. Posts are spaced no more than 6- to 10-feet apart. Light-duty scaffolding must be able to support 25-pound-per-square-foot loads.

Medium-duty scaffolding normally uses 2-inch-outside-diameter steel-tubing bearers. Posts should be spaced no more than 5- to 8-feet apart. If 2 1/2-inch-outside-diameter steel-tubing bearers are used, posts are be spaced 6- to 8-feet apart. Medium-duty scaffolding must be able to support 50-pound-per-square-foot loads.

Heavy-duty scaffolding should have bearers of 2-1/2-inch-outside-diameter steel tubing with the posts spaced not more than 6-feet to 6-feet 6-inches apart. This scaffolding must be able to support 75-pound-per-square-foot loads.

To find the load per square foot of a pile of materials on a platform, divide the total weight of the pile by the number of square feet of platform it covers.

**BRACKET SCAFFOLDING**

The bracket, or carpenter's scaffold (figure 4-46), is built of a triangular wood frame not less than 2- by 3-inch lumber or metal of equivalent strength. Each bracket is attached to the structure in one of four ways: a bolt (at least 5/8 inch) that extends through to the inside of the building wall; a metal stud

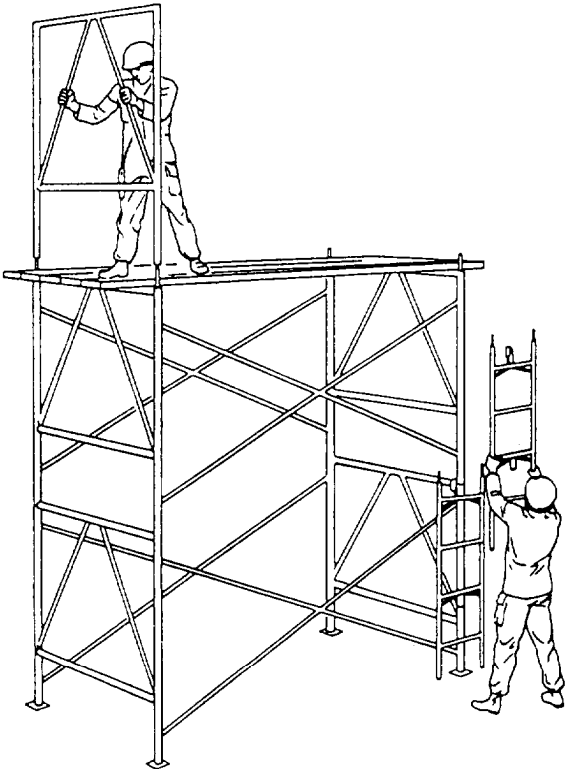

Figure 4-44.—Assembling prefabricated independent-pole scaffolding.

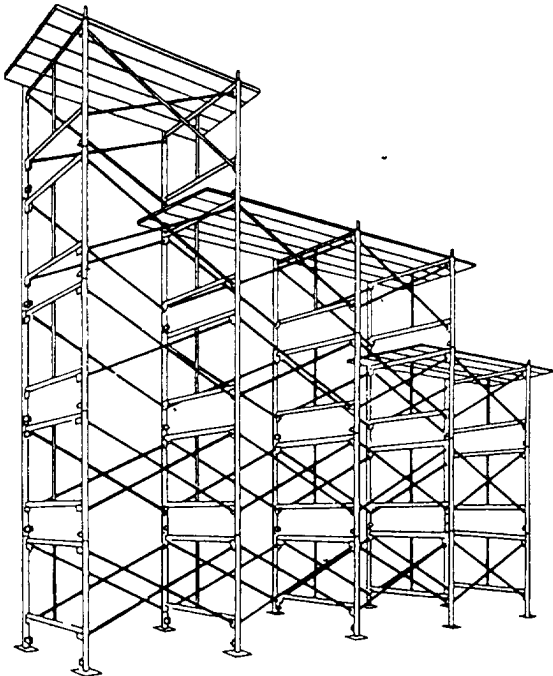

Figure 4-45.—Tiered scaffolding.

attachment device; welded to a steel tank; or hooked over a secured supporting member.

The brackets must be spaced no more than 8-feet apart. No more than two persons should be on any 8-foot section at one time. Tools and materials used on the scaffold should not exceed 75 pounds.

The platform is built of at least two 2- by 10-inch nominal size planks. The planks should extend between 6 and 12 inches beyond each support.

## SCAFFOLD SAFETY

When working on scaffolding or tending others on scaffolding, you must observe all safety precautions. Builder petty officers must not only observe the safety precautions themselves, but they must also issue them to their crew and ensure that the crew observes them.

## RECOMMENDED READING LIST

### NOTE

Although the following references were current when this TRAMAN was published, their continued currency cannot be assured. You therefore need to ensure that you are studying the latest revisions.

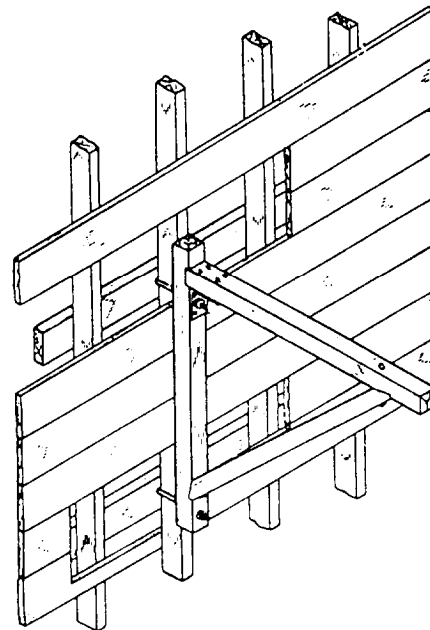

Figure 4-46.—Carpenter's portable bracket for scaffolding.

*Navy Occupational Safety and Health (NAVOSH) Program Manual for Forces Afloat, Volume I, Office of the Chief of Naval Operations (OP-45), Washington, D.C., 1989.*

*Safety and Health Requirements Manual, EM 385-1-1, U.S. Army Corps of Engineers, Washington, D.C. 1981.*



## CHAPTER 5

# LEVELING AND GRADING

This chapter describes the common types of leveling instruments. It also describes their principles, uses, procedures of establishing elevations, and techniques of laying outbuilding lines. As a Builder, you will find the information especially useful in performing such duties as setting up a level, reading a leveling rod, interpreting and setting grade stakes, and setting batterboards. Also included in this chapter are practices and measures that help prevent slides and cave-ins at excavation sites, and the procedures for computing volume of land mass.

### LEVELS

*LEARNING OBJECTIVE: Upon completing this section, you should be able to describe the types of leveling instruments and their uses.*

The engineer's level, often referred to as the "dumpy level," is the instrument most commonly used to attain the level line of sight required for differential leveling (defined later). The dumpy level and the self-leveling level can be mounted for use on a tripod, usually with adjustable legs (figure 5-1).

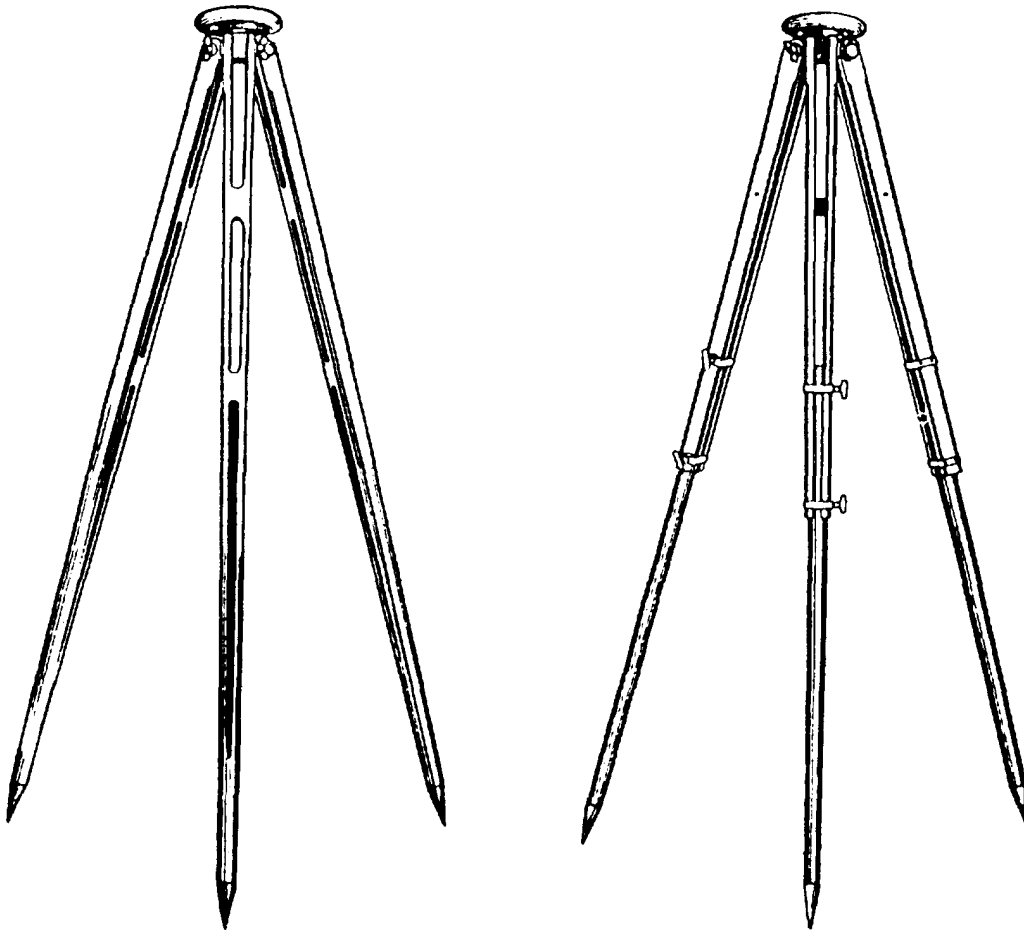

Figure 5-1.—Tripods.

Mounting is done by engaging threads at the base of the instrument (called the footplate) with the threaded head on the tripod. These levels are the ones most frequently used in ordinary leveling projects. For rough leveling, the hand level is used.

### DUMPY LEVEL

Figure 5-2 shows a dumpy level and its nomenclature. Notice that the telescope is rigidly fixed to the supporting frame.

Inside the telescope there is a ring, or diaphragm, known as the reticle, which supports the cross hairs. The cross hairs are brought into exact focus by manipulating the knurled eyepiece focusing ring near the eyepiece, or the eyepiece itself on some models. If the cross hairs get out of horizontal adjustment, they can be made horizontal again by slackening the reticle adjusting screws and turning the screws in the appropriate direction. This adjustment should be performed only by trained personnel. The object to which you are sighting, regardless of shape, is called a target. The target is brought into clear focus by manipulating the focusing knob shown on top of the

telescope. The telescope can be rotated only horizontally, but, before it can be rotated, the azimuth clamp must be released. After training the telescope as nearly on the target as you can, tighten the azimuth clamp. You then bring the vertical cross hair into exact alignment on the target by rotating the azimuth tangent screw.

The level vial, leveling head, leveling screws, and footplate are all used to adjust the instrument to a perfectly level line of sight once it is mounted on the tripod.

### SELF-LEVELING LEVEL

You can save time using the self-leveling, or so-called "automatic," level in leveling operations. The self-leveling level (figure 5-3) has completely eliminated the use of the tubular spirit level, which required excessive time because it had to be reset quite often during operation.

The self-leveling level is equipped with a small bull's-eye level and three leveling screws. The leveling screws, which sit on a triangular footplate,

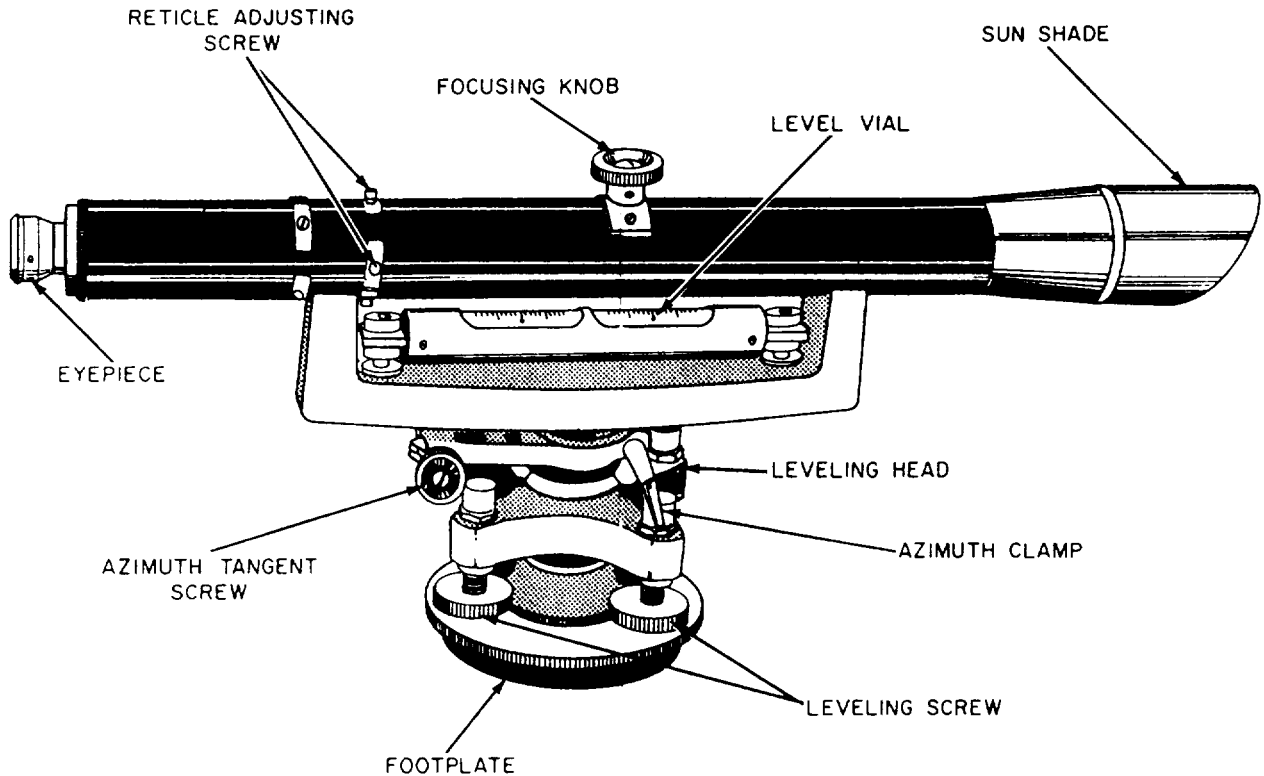

Figure 5-2.—Dumpy level.



are used to center, as much as possible, the bubble of the bull's-eye level. The line of sight automatically becomes horizontal and remains horizontal as long as the bubble remains approximately centered.

### HAND LEVEL

The hand level, like all surveying levels, is an instrument that combines a level vial and a sighting device. Figure 5-4 shows the Locke level, a type of hand level. A horizontal line, called an index line, is provided in the sight tube as a reference line. The level vial is mounted atop a slot in the sighting tube in which a reflector is set at a 45° angle. This permits the observer, who is sighting through the tube, to see the object, the position of the level bubble in the vial, and the index line at the same time.

To get the correct sighting through the tube, you should stand straight, using the height of your eye (if known) above the ground to find the target. When your eye height is not known, you can find it by sighting the rod at eye height in front of your body. Since the distances over which you sight a hand level are rather short, no magnification is provided in the tube.

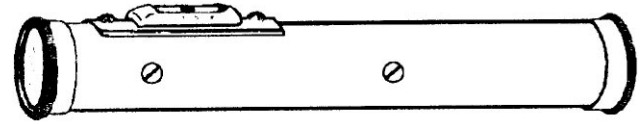

Figure 5-4.—Locke level.

### SETTING UP A LEVEL

After you select the proper location for the level, your first step is to set up the tripod. This is done by spreading two of the legs a convenient distance apart and then bringing the third leg to a position that will bring the protector cap (which covers the tripod head threads) about level when the tripod stands on all three legs. Then, unscrew the protector cap, which exposes the threaded head, and place it in the carrying case where it will not get lost or dirty. The tripod protective cap should be in place when the tripod is not being used.

Lift the instrument out of the carrying case by the footplate—not by the telescope. Set it squarely and gently on the tripod head threads and engage the head nut threads under the footplate by rotating the footplate clockwise. If the threads will not engage

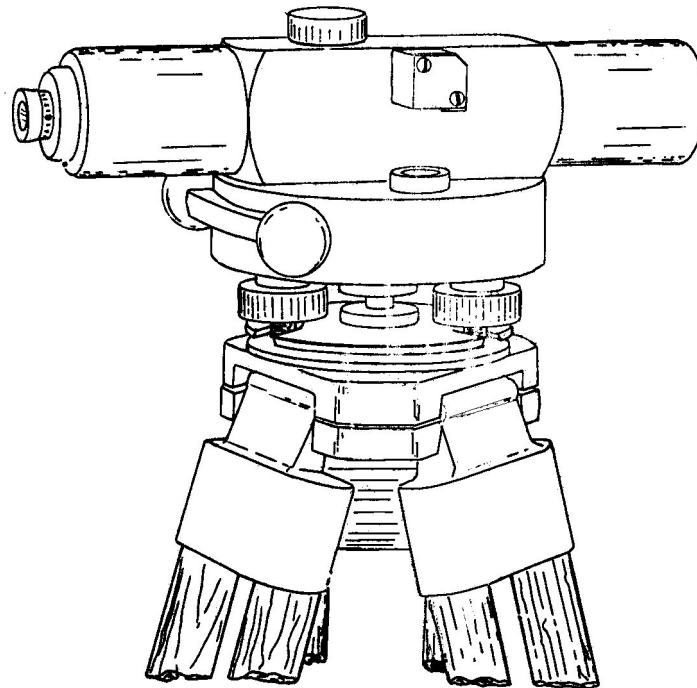

Figure 5-3.—Self-leveling level.

smoothly, they may be cross-threaded or dirty. Do not force them if you encounter resistance; instead, back off, and, after checking to see that they are clean, square up the instrument, and then try again gently. Screw the head nut up firmly, but not too tightly. Screwing it too tightly causes eventual wearing of the threads and makes unthreading difficult. After you have attached the instrument, thrust the leg tips into the ground far enough to ensure that each leg has stable support, taking care to maintain the footplate as near level as possible. With the instrument mounted and the legs securely positioned in the soil, the thumbscrews at the top of each leg should be firmly tightened to prevent any possible movement.

Quite frequently, the Builder must set up the instrument on a hard, smooth surface, such as a concrete pavement. Therefore, steps must be taken to prevent the legs from spreading. Figure 5-5 shows

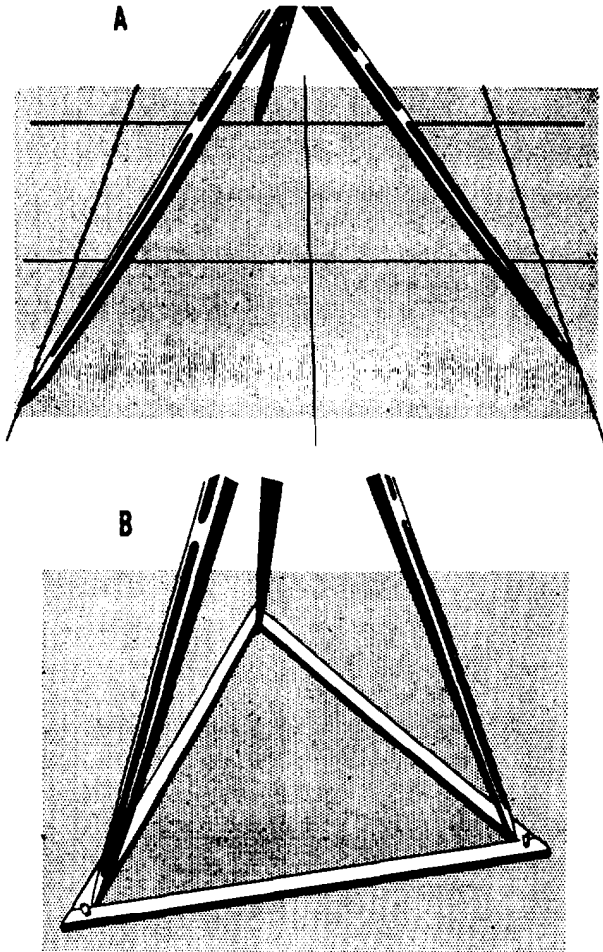

Figure 5-5.—Methods of preventing tripod legs from spreading.

two good ways of doing this. In view A, the tips of the legs are inserted in joints in the pavement. In view B, the tips are held by a wooden floor triangle.

### LEVELING A LEVEL

To function accurately, the level must provide a line of sight that is perfectly horizontal in any direction the telescope is trained. To ensure this, you must level the instrument as discussed in the next paragraphs.

When the tripod and instrument are first set up, the footplate should be made as nearly level as possible. Next, train the telescope over a pair of diagonally opposite leveling screws, and clamp it in that position. Then, manipulate the leveling thumbscrews, as shown in figure 5-6, to bring the bubble in the level vial exactly into the marked center position.

The thumbscrews are manipulated by simultaneously turning them in opposite directions, which shortens one spider leg (threaded member running through the thumbscrew) while it lengthens the other. It is helpful to remember that the level vial bubble will move in the same direction that your left thumb moves while you rotate the thumbscrews. In other words, when your left thumb pushes the thumbscrew clockwise, the bubble will move towards your left hand; when you turn the left thumbscrew counter-clockwise, the bubble moves toward your right hand.

After leveling the telescope over one pair of screws, train it over the other pair and repeat the process. As a check, set the telescope in all four possible positions and be sure that the bubble centers exactly in each.

Various techniques for using the level will develop with experience; however, in this section we will only discuss the techniques that we believe are essential to the Builder rating.

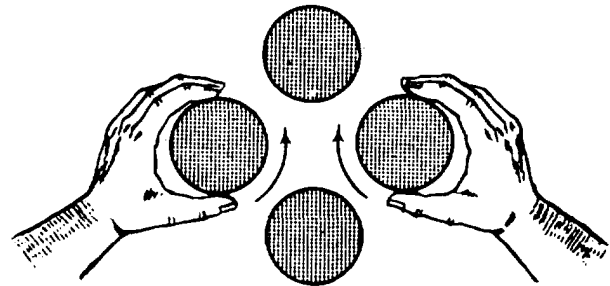

Figure 5-6.—Manipulating leveling thumbscrews.

## CARE OF LEVELS

An engineer's level is a precision instrument containing many delicate and fragile parts. It must therefore be handled gently and with the greatest care at all times; it must never be subjected to shock or jar. Movable parts (if not locked or clamped in place) should work easily and smoothly. If a movable part resists normal pressure, there is something wrong. If you force the part to move, you will probably damage the instrument. You will also cause wear or damage if you excessively tighten clamps and screws.

The only proper place to stow the instrument when it is detached from the tripod is in its own carrying box or case. The carrying case is designed to reduce the effect of jarring to a minimum. It is strongly made and well padded to protect the instrument from damage. Before stowing, the azimuth clamp and leveling screws should be slightly tightened to prevent movement of parts inside the box. When it is being transported in a vehicle, the case containing the instrument should be placed as nearly as possible midway between the front and rear wheels. This is the point where jarring of the wheels has the least effect on the chassis.

You should never lift the instrument out of the case by grasping the telescope. Wrenching the telescope in this manner will damage a number of delicate parts. Instead, lift it out by reaching down and grasping the footplate or the level bar.

When the instrument is attached to the tripod and carried from one point to another, the azimuth clamp and level screws should be set up tight enough to prevent part motion during the transport but loose enough to allow a "give" in case of an accidental bump against some object. When you are carrying the instrument over terrain that is free of possible contacts (across an open field, for example), you may carry it over your shoulder like a rifle. When there are obstacles around, you should carry it as shown in figure 5-7. Carried in this manner, the instrument is always visible



Figure 5-7.—Safest carrying position for instrument when obstacles may be encountered.

to you, and this makes it possible for you to avoid striking it against obstacles.

## LEVELING RODS

*LEARNING OBJECTIVE: Upon completing this section, you should be able to interpret the readings from a leveling rod.*

A leveling rod, in essence, is a tape supported vertically that is used to measure vertical distance (difference in elevation) between a line of sight and a required point above or below it. Although there are several types of rods, the most popular and frequently used is the Philadelphia rod. Figure 5-8 shows the face and back of this rod.

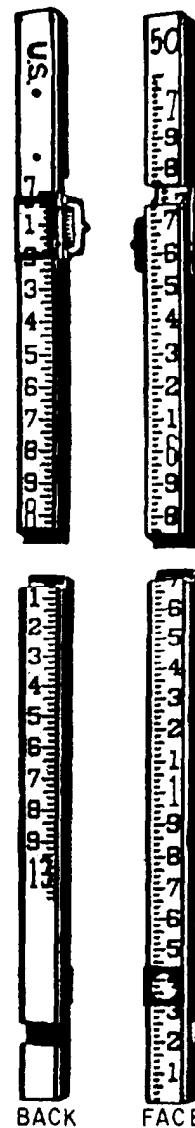

Figure 5-8.—Back and face of Philadelphia leveling rod.

The Philadelphia rod consists of two sliding sections, which can be fully extended to a total length of 13.10 feet. When the sections are entirely closed, the total length is 7.10 feet. For direct readings (that is, for readings on the face of the rod) of up to 7.10 and 13.10 feet, the rod is used extended and read on the back by the rodman. If you are in the field and don't have a Philadelphia rod, you can use a 1-by-4 with a mark or a 6-foot wooden ruler attached to a 2-by-4.

In direct readings, the person at the instrument reads the graduation on the rod intercepted by the cross hair through the telescope. In target readings, the rodman reads the graduation on the face of the rod intercepted by a target. In figure 5-8, the target does not appear; however, it is shown in figure 5-9. As you can see, it is a sliding, circular device that can be moved up or down the rod and clamped in position.

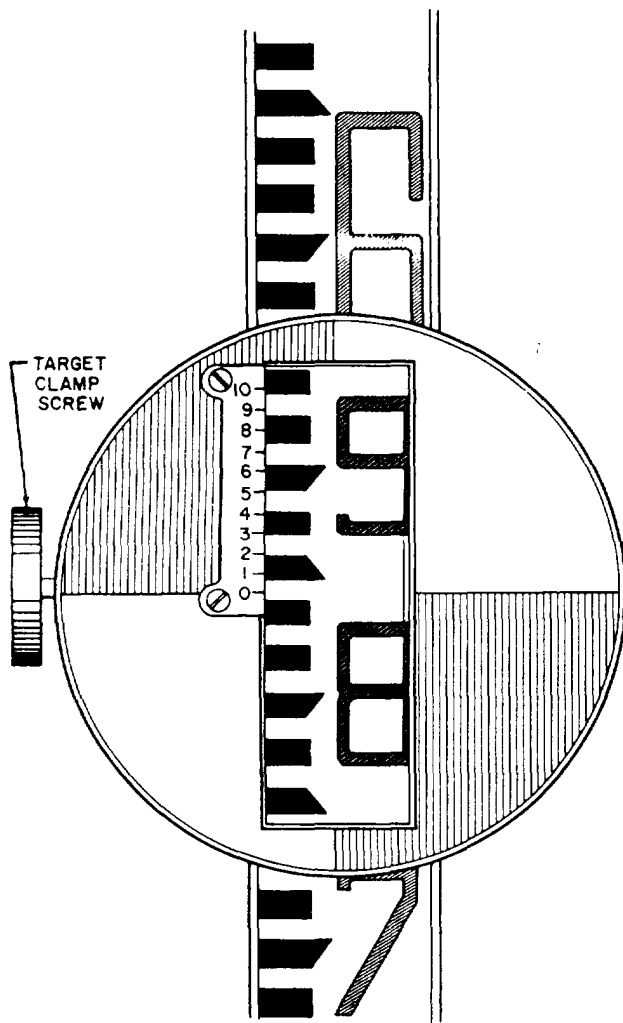

Figure 5-9.—Philadelphia rod set for target reading of less than 7,000 feet.

is placed by the rodman on signals given by the instrumentman.

The rod shown in the figures is graduated in feet and hundredths of a foot. Each even foot is marked with a large red numeral, and, between each pair of adjacent red numerals, the intermediate tenths of a foot are marked with smaller black numerals. Each intermediate hundredth of a foot between each pair of adjacent tenths is indicated by the top or bottom of one of the short, black dash graduations.

## DIRECT READINGS

As the levelman, you can make direct readings on a self-reading rod held plumb on the point by the rodman. If you are working to tenths of a foot, it is relatively simple to read the footmark below the cross hair and the tenth mark that is closest to the cross hair. If greater precision is required, and you must work to hundredths, the reading is more complicated (see figure 5-10).

For example, suppose you are making a direct reading that should come out to 5.67 feet. If you are using a Philadelphia rod, the interval between the top and the bottom of each black graduation and the interval between the black graduations (figure 5-11 ) each represent 0.01 foot. For a reading of 5.76 feet, there are three black graduations between the 5.70-foot mark and the 5.76-foot mark. Since there are three graduations, a beginner may have a tendency to misread 5.76 feet as 5.73 feet.

As you can see, neither the 5-foot mark nor the 6-foot mark is shown in figure 5-11. Sighting through the telescope, you might not be able to see the foot marks to which you must refer for the reading. When you cannot see the next lower foot mark through the telescope, it is a good idea to order the rodman to **raise the red**. On the Philadelphia rod, whole feet numerals are in red. Upon hearing this order, the rodman slowly raises the rod until the next lower red figure comes into view.

## TARGET READINGS

For more precise vertical measurements, level rods may be equipped with a rod target that can be set and clamped by the rodman at the directions of the instrumentman. When the engineer's level rod target and the vernier scale are being used, it is possible to make readings of 0.001 (one-thousandth of a foot), which is slightly smaller than one sixty-fourth of an

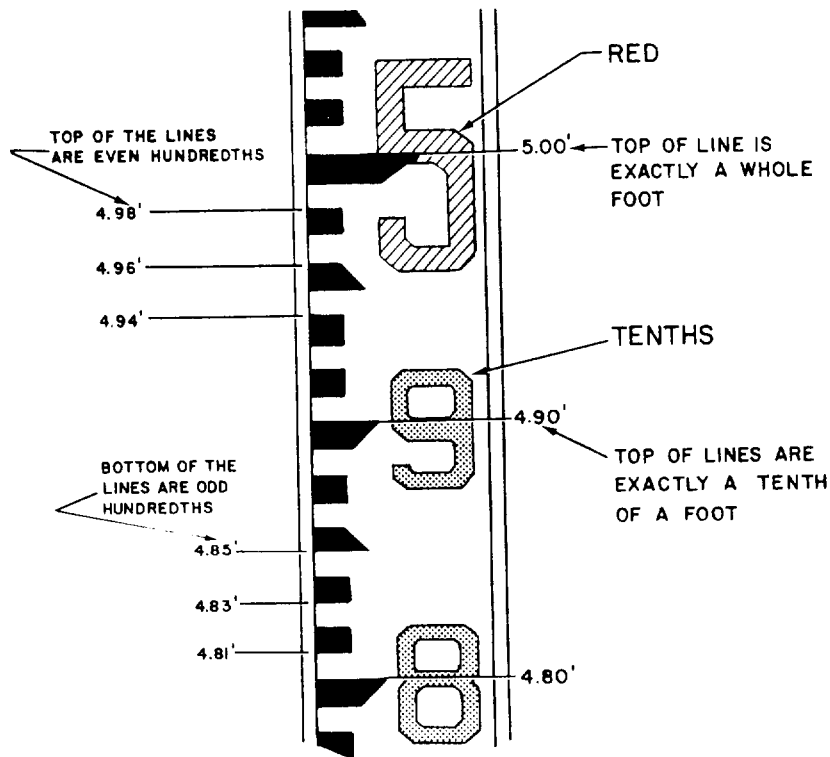

Figure 5-10.—Philadelphia rod marking.

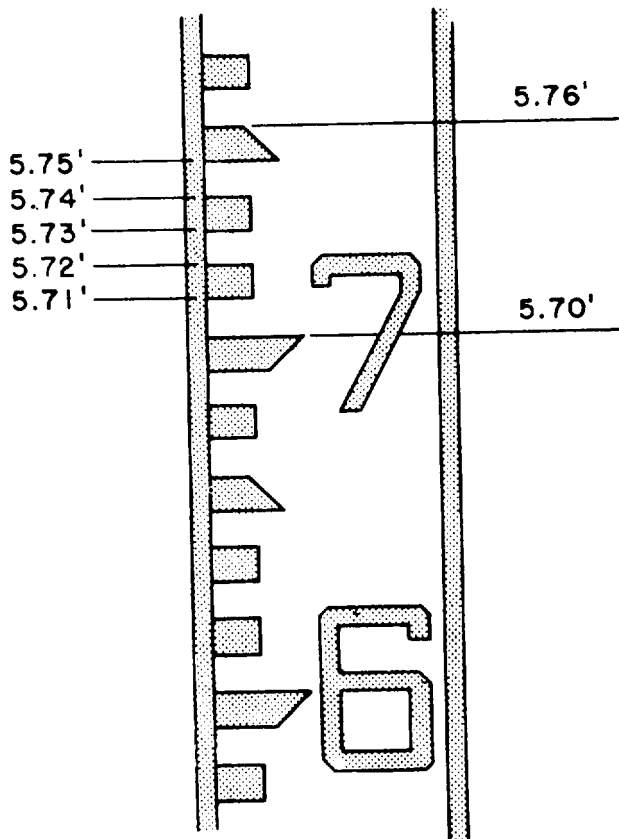

Figure 5-11.—Direct reading of 5.76 ft on Philadelphia rod.

inch. The indicated reading of the target can be read either by the rodman or the instrumentman. In figure 5-12, you can see that the 0 on the vernier scale is in exact alignment with the 4-foot mark. If the position of the 0 on the target is not in exact alignment with a line on the rod, go up the vernier scale on the target to the line that is in exact alignment with the hundredths line on the rod, and the number located will be the reading in thousandths.

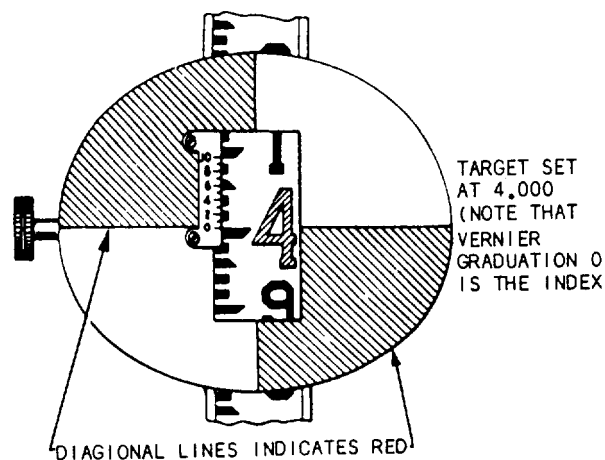

Figure 5-12.—Target.

There are three situations in which target reading, rather than direct reading, is done on the face of the rod:

- When the rod is too far from the level to be read directly through the telescope;
- When a reading to the nearest 0.001 foot, rather than to the nearest 0.01 foot, is desired (a vernier on the target or on the back of the rod makes this possible);
- When the instrumentman desires to ensure against the possibility of reading the wrong foot (large red letter) designation on the rod.

For target readings up to 7.000 feet, the rod is used fully closed, and the rodman, on signals from the instrumentman, sets the target at the point where its horizontal axis is intercepted by the cross hair, as seen through the telescope. When the target is located, it is clamped in place with the target screw clamp, as shown in figure 5-9. When a reading to only the nearest 0.01 foot is desired, the graduation indicated by the target's horizontal axis is read; in figure 5-9, this reading is 5.84 feet.

If reading to the nearest 0.001 foot is desired, the rodman reads the vernier (small scale running from 0 to 10) on the target. The 0 on the vernier indicates that the reading lies between 5.840 feet and 5.850 feet. To determine how many thousandths of a foot over 5.840 feet, you examine the graduations on the vernier to determine which one is most exactly in line with a graduation (top or bottom of a black dash) on the rod. In figure 5-9, this graduation on the vernier is the 3; therefore, the reading to the nearest 0.001 foot is 5.843 feet.

For target readings of more than 7.000 feet, the procedure is a little different. If you look at the left-hand view of figure 5-8 (showing the back of the rod), you will see that only the back of the upper section is graduated, and that it is graduated downward from 7.000 feet at the top to 13.09 feet at the bottom. You can also see there is a rod vernier fixed to the top of the lower section of the rod. This vernier is read against the graduations on the back of the upper section.

For a target reading of more than 7.000 feet, the rodman first clamps the target at the upper section of the rod. Then, on signals from the instrumentman, the rodman extends the rod upward to the point where the horizontal axis of the target is intercepted by the cross hair. The rodman then clamps the rod, using the rod

clamp screw shown in figure 5-13, and reads the vernier on the back of the rod, also shown in that figure. In this case, the 0 on the vernier indicates a certain number of thousandths more than 7.100 feet. Remember, that in this case, you read the rod and the vernier down from the top, not up from the bottom. To determine the thousandths, determine which vernier graduation lines up most exactly with a graduation on the rod. In this case, it is the 7; therefore, the rod reading is 7.107 feet.

### Rod Levels

A rod reading is accurate only if the rod is perfectly plumb (vertical) at the time of the reading. If the rod is out of plumb, the reading will be greater than the actual vertical distance between the height of

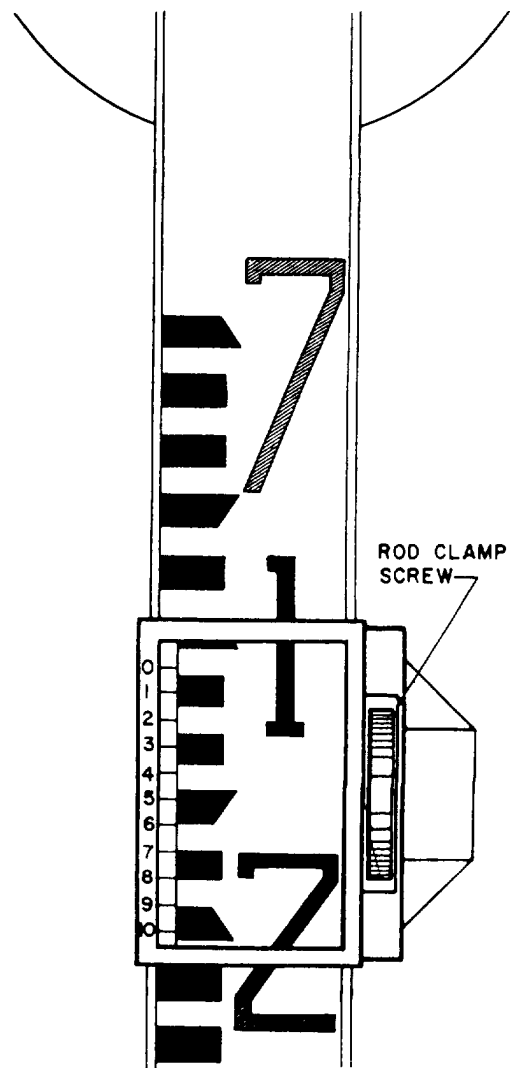

Figure 5-13.—Philadelphia rod target reading of more than 7.000 ft.

instrument (H.I.) and the base of the rod. On a windy day, the rodman may have difficulty holding the rod plumb. In this case, the levelman can have the rodman wave the rod back and forth, allowing the levelman to read the lowest reading touched on the engineer's level cross hairs.

The use of a rod level ensures a vertical rod. A bull's-eye rod level is shown in figure 5-14. When it is held as shown (on a part of the rod where readings are not being taken to avoid interference with the instrumentman's view of the scale) and the bubble is centered, the rod is plumb. A vial rod level has two spirit vials, each of which is mounted on the upper edge of one of a pair of hinged metal leaves. The vial level is used like the bull's-eye level, except that two bubbles must be watched instead of one.

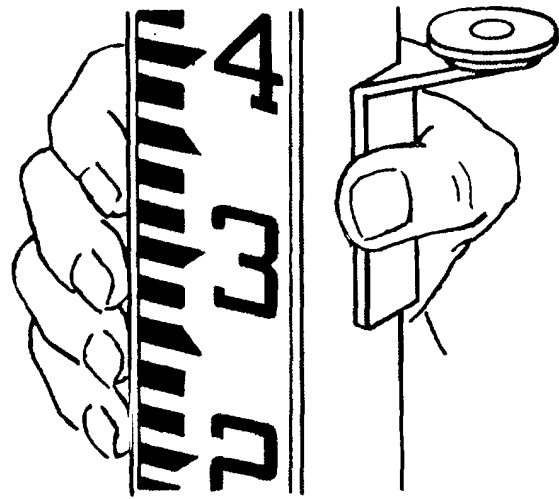

Figure 5-14.—Bull's-eye rod level.

### Care of Leveling Rods

A leveling rod is a precision instrument and must be treated as such. Most rods are made of carefully selected, kiln-dried, well-seasoned hardwood. Scale graduations and numerals on some are painted directly on the wood; however, on most rods they are painted on a metal strip attached to the wood. Unless a rod is handled at all times with great care, the painted scale will soon become scratched, dented, worn, or otherwise marked and obscured. Accurate readings on a scale in this condition are difficult.

Allowing an extended sliding-section rod to close on the run, by permitting the upper section to drop, may jar the vernier scale out of position or otherwise damage the rod. Always close an extended rod by easing the upper section down gradually.

A rod will read accurately only if it is perfectly straight. It follows, then, that anything that might bend or warp the rod must be avoided. Do not lay a rod down flat unless it is supported throughout, and never use a rod for a seat, a lever, or a pole vault. In short, never use a rod for any purpose except the one for which it is designed.

Store a rod not in use in a dry place to avoid warping and swelling caused by dampness. Always wipe off a wet rod before putting it away. If there is dirt on the rod, rinse it off, but do not scrub it off. If a soap solution must be used (to remove grease, for example), make it a very mild one. The use of a strong soap solution will soon cause the paint on the rod to degenerate.

Protect a rod as much as possible against prolonged exposure to strong sunlight. Such exposure causes paint to chalk (that is, degenerate into a chalk-like substance that flakes from the surface).

### DIFFERENTIAL LEVELING

*LEARNING OBJECTIVE: Upon completing this section, you should be able to determine elevations in the field to locate points at specified elevations.*

The most common procedure for determining elevations in the field, or for locating points at specified elevations, is known as differential leveling. This procedure, as its name implies, is nothing more than finding the vertical difference between the known or assumed elevation of a bench mark and the elevation of the point in question. Once the difference is measured, it can (depending on the circumstances) be added to or subtracted from the bench mark elevation to determine the elevation of the new point.

### ELEVATION AND REFERENCE

The elevation of any object is its vertical distance above or below an established height on the earth's surface. This established height is referred to as either a "reference plane" or "simple reference." The most commonly used reference plane for elevations is mean (or average) sea level, which has been assigned an assumed elevation of 000.0 feet. However, the reference plane for a construction project is usually the height of some permanent or semipermanent

object in the immediate vicinity, such as the rim of a manhole cover, a rod, or the finish floor of an existing structure. This object may be given its relative sea level elevation (if it is known); or it may be given a convenient, arbitrarily assumed elevation, usually a whole number, such as 100.0 feet. An object of this type, with a given, known, or assumed elevation, which is to be used in determining the elevations of other points, is called a bench mark.

## PRINCIPLES OF DIFFERENTIAL LEVELING

Figure 5-15 illustrates the principle of differential leveling. The instrument shown in the center represents an engineer's level. This optical instrument provides a perfectly level line of sight through a telescope, which can be trained in any direction. Point A in the figure is a bench mark (it could be a concrete monument, a wooden stake, a sidewalk curb, or any other object) having a known elevation of 365.01 feet. Point B is a ground surface point whose elevation is desired.

The first step in finding the elevation point of point B is to determine the elevation of the line of sight of the instrument. This is known as the height of instrument and is often written and referred to simply as "H.I." To determine the H.I., you take a backsight on a level rod held vertically on the bench mark (B.M.) by a rodman. A backsight (B.S.) is always

taken after a new instrument position is set up by sighting back to a known elevation to get the new H.I. A leveling rod is graduated upward in feet, from 0 at its base, with appropriate subdivisions in feet.

In figure 5-15, the backsight reading is 11.56 feet. Thus, the elevation of the line of sight (that is, the H.I.) must be 11.56 feet greater than the bench mark elevation, point A. Therefore, the H.I. is 365.01 feet plus 11.56 feet, or 376.57 feet as indicated.

Next, you train the instrument ahead on another rod (or more likely, on the same rod carried ahead) held vertically on B. This is known as taking a foresight. After reading a foresight (F.S.) of 1.42 feet on the rod, it follows that the elevation at point B must be 1.42 feet lower than the H.I. Therefore, the elevation of point B is 376.57 feet minus 1.42 feet, or 375.15 feet.

## GRADING

The term "grade" is used in several different senses in construction. In one sense, it refers to the steepness of a slope; for example, a slope that rises 3 vertical feet for every 100 horizontal feet has a grade of 3 percent. Although the term "grade" is commonly used in this sense, the more accurate term for indicating steepness of slope is "gradient."

In another sense, the term "grade" simply means surface. On a wall section, for example, the line that

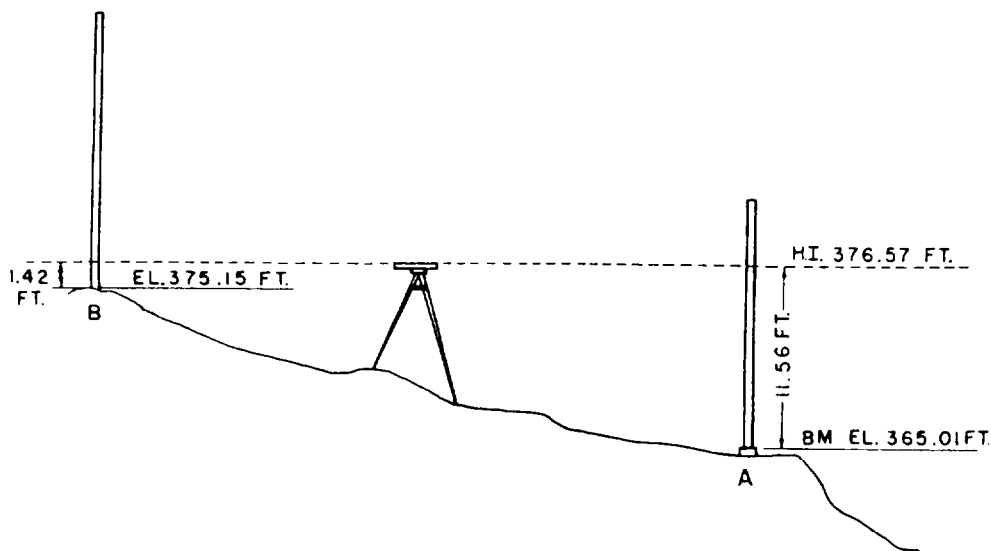

Figure 5-15.—Procedure for differential leveling.



indicates the ground surface level outside the building is marked "Grade" or "Grade Line."

The elevation of a surface at a particular point is a grade elevation. A grade elevation may refer to an existing, natural earth surface or to a hub or stake used as a reference point, in which case the elevation is that of existing grade or existing ground. It may also refer to a proposed surface to be created artificially, in which case the elevation is that of prescribed grade, plan grade, or finished grade.

Grade elevations of the surface area around a structure are indicated on the plot plan. Because a natural earth surface is usually irregular in contour, existing grade elevations on such a surface are indicated by contour lines on the plot plan; that is, by lines that indicate points of equal elevation on the ground. Contour lines that indicate existing grade are usually made dotted; however, existing contour lines on maps are sometimes represented by solid lines. If the prescribed surface to be created artificially will be other than a horizontal-plane surface, prescribed grade elevations will be indicated on the plot plan by solid contour lines.

On a level, horizontal-plane surface, the elevation is the same at all points. Grade elevation of a surface of this kind cannot be indicated by contour lines because each contour line indicates an elevation different from that of each other contour line. Therefore, a prescribed level surface area, to be artificially created, is indicated on the plot plan by outlining the area and inscribing inside the outline the prescribed elevation, such as "First floor elevation 127.50 feet."

## BUILDING LAYOUT

*LEARNING OBJECTIVE: Upon completing this section, you should be able to determine boundaries of building layout.*

Before foundation and footing excavation for a building can begin, the building lines must be laid out to determine the boundaries of the excavations. Points shown on the plot plan, such as building corners, are located at the site from a system of horizontal control points established by the battalion engineering aids. This system consists of a framework of stakes, driven pipes, or other markers located at points of known horizontal location. A point in the structure, such as a building corner, is located on the ground by reference to one or more nearby horizontal control points.

We cannot describe here all the methods of locating a point with reference to a horizontal control point of a known horizontal location. We will take, as an illustrative example, the situation shown in figure 5-16. This figure shows two horizontal control points, consisting of monuments A and B. The term "monument," incidentally, doesn't necessarily mean an elaborate stone or concrete structure. In structural horizontal control, it simply means any permanently located object, either artificial (such as a driven length of pipe) or natural (such as a tree) of known horizontal location.

In figure 5-16, the straight line from A to B is a control base line from which the building corners of the structure can be located. Corner E, for example, can be located by first measuring 15 feet along the base line from A to locate point C; then measuring off 35 feet on CE, laid off at 90° to (that is, perpendicular to) AB. By extending CE another 20 feet, you can locate building corner F. Corners G and H can be similarly located along a perpendicular run from point D, which is itself located by measuring 55 feet along the base line from A.

## PERPENDICULAR BY PYTHAGOREAN THEOREM

The easiest and most accurate way to locate points on a line or to turn a given angle, such as 90°,

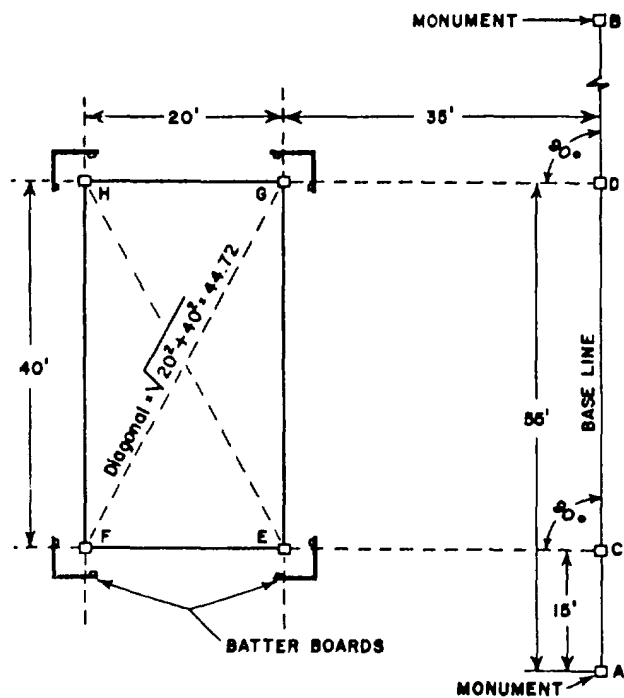

Figure 5-16.—Locating building corners.

from one line to another is to use a surveying instrument called a transit. However, if you do not have a transit, you can locate the corner points with tape measurements by applying the Pythagorean theorem. First, stretch a cord from monument A to monument B, and locate points C and D by tape measurements from A. Now, if you examine figure 5-16, you will observe that straight lines connecting points C, D, and E form a right triangle with one side 40 feet long and the adjacent side 35 feet long. By the Pythagorean theorem, the length of the hypotenuse of this triangle (the line ED) is equal the square root of  $35^2 + 40^2$ , which is approximately 53.1 feet. Because figure EGDC is a rectangle, the diagonals both ways (ED and CG) are equal. Therefore, the line from C to G should also measure 53.1 feet. If you have one person hold the 53.1-foot mark of a tape on D, have another hold the 35-foot mark of another tape on C, and have a third person walk away with the joined 0-foot ends, when the tapes come taut, the joined 0-foot ends will lie on the correct location for point E. The same procedure, but this time with the 53.1-foot length of tape running from C and the 35-foot length running from D, will locate corner point G. Corner points F and H can be located by the same process, or by extending CE and DG 20 feet.

### PERPENDICULAR BY 3:4:5 TRIANGLE

If you would rather avoid the square root calculations required in the Pythagorean theorem method, you can apply the basic fact that any triangle with sides in the proportions of 3:4:5 is a right triangle. In locating point E, you know that this point lies 35 feet from C on a line perpendicular to the base line. You also know that a triangle with sides 30 and 40 feet long and a hypotenuse 50 feet long is a right triangle.

To get the 40-foot side, you measure off 40 feet from C along the base line; in figure 5-16, the segment from C to D happens to measure 40 feet. Now, if you run a 50-foot tape from D and a 30-foot tape from C, the joined ends will lie on a line perpendicular from the base line, 30 feet from C. Drive a hub at this point, and extend the line to E (5 more feet) by stretching a cord from C across the mark on the hub.

### BATTER BOARDS

Hubs driven at the exact locations of building corners will be disturbed as soon as the excavation for the foundation begins. To preserve the corner locations, and also to provide a reference for measurement down to the prescribed elevations, batter boards are erected as shown in figure 5-17.

Each pair of boards is nailed to three 2-by-4 corner stakes as shown. The stakes are driven far enough outside the building lines so that they will not be disturbed during excavation. The top edges of the boards are located at a specific elevation, usually some convenient number of whole feet above a significant prescribed elevation, such as that at the top of the foundation. Cords located directly over the lines through corner hubs, placed by holding plumb bobs on the hubs, are nailed to the batter boards. Figure 5-17 shows how a corner point can be located in the excavation by dropping a plumb bob from the point of intersection between two cords.

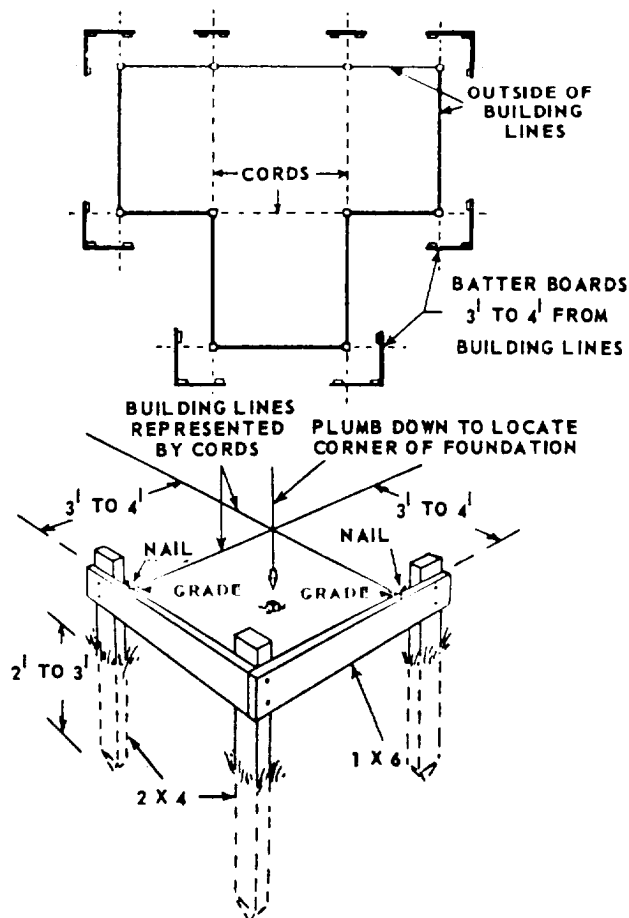

Figure 5-17.—Batter boards.

In addition to their function in horizontal control, batter boards are also used for vertical control. The top edge of a batter board is placed at a specific elevation. Elevations of features in the structure, such as foundations and floors, can be located by measuring downward or upward from the cords stretched between the batter boards.

You should always make sure that you have complete information as to exactly what lines and elevations are indicated by the batter boards. You should emphasize to your crewmembers that they exercise extreme caution while working around batter boards. If the boards are damaged or moved, additional work will be required to replace them and to relocate reference points.

## RECOMMENDED READING LIST

### NOTE

Although the following reference was current when this TRAMAN was published, its continued currency cannot be assured. You therefore need to ensure that you are studying the latest revision.

*Engineering Aid 3 & 2*, Vol. 3, NAVEDTRA 10629-1, Naval Education and Training Program Management Support Activity, Pensacola, Fla., 1987.



## CHAPTER 6

# CONCRETE

Concrete is one of the most important construction materials. It is comparatively economical, easy to make, offers continuity and solidity, and will bond with other materials. The keys to good-quality concrete are the raw materials required to make concrete and the mix design as specified in the project specifications. In this chapter, we'll discuss the characteristics of concrete, the ingredients of concrete, concrete mix designs, and mixing concrete. We'll conclude the chapter with a discussion of precast and tilt-up concrete. At the end of the discussion, we provide helpful references. You are encouraged to study these references, as required, for additional information on the topics discussed.

### CONCRETE CHARACTERISTICS

*LEARNING OBJECTIVE: Upon completing this section, you should be able to define the characteristics of concrete.*

Concrete is a synthetic construction material made by mixing cement, fine aggregate (usually sand), coarse aggregate (usually gravel or crushed stone), and water in the proper proportions. The product is not concrete unless all four of these ingredients are present.

### CONSTITUENTS OF CONCRETE

The fine and coarse aggregates in a concrete mix are the inert, or inactive, ingredients. Cement and water are the active ingredients. The inert ingredients and the cement are first thoroughly mixed together. As soon as the water is added, a chemical reaction begins between the water and the cement. The reaction, called hydration, causes the concrete to harden. This is an important point. The hardening process occurs through hydration of the cement by the water, not by drying out of the mix. Instead of being dried out, concrete must be kept as moist as possible during the initial hydration process. Drying out causes a drop in water content below that required for satisfactory hydration of the cement. The fact that the hardening process does not result from drying out is clearly shown by the fact that concrete hardens just as well underwater as it does in air.

### CONCRETE AS BUILDING MATERIAL

Concrete may be cast into bricks, blocks, and other relatively small building units, which are used in concrete construction. Concrete has a great variety of applications because it meets structural demands and lends itself to architectural treatment. All important building elements, foundations, columns, walls, slabs, and roofs are made from concrete. Other concrete applications are in roads, runways, bridges, and dams.

### STRENGTH OF CONCRETE

The compressive strength of concrete (meaning its ability to resist compression) is very high, but its tensile strength (ability to resist stretching, bending, or twisting) is relatively low. Consequently, concrete which must resist a good deal of stretching, bending, or twisting—such as concrete in beams, girders, walls, columns, and the like—must be reinforced with steel. Concrete that must resist only compression may not require reinforcement. As you will learn later, the most important factor controlling the strength of concrete is the water-cement ratio, or the proportion of water to cement in the mix.

### DURABILITY OF CONCRETE

The durability of concrete refers to the extent to which the material is capable of resisting deterioration caused by exposure to service conditions. Concrete is also strong and fireproof. Ordinary structural concrete that is to be exposed to the elements must be watertight and weather-resistant. Concrete that is subject to wear, such as floor slabs and pavements, must be capable of resisting abrasion.

The major factor that controls the durability of concrete is its strength. The stronger the concrete, the more durable it is. As we just mentioned, the chief factor controlling the strength of concrete is the water-cement ratio. However, the character, size, and grading (distribution of particle sizes between the largest permissible coarse and the smallest permissible fine) of the aggregate also have important effects on both strength and durability. However,

maximum strength and durability will still not be attained unless the sand and coarse aggregate you use consist of well-graded, clean, hard, and durable particles free of undesirable substances (figure 6-1).

## **WATERTIGHTNESS OF CONCRETE**

The ideal concrete mix is one with just enough water required for complete hydration of the cement. However, this results in a mix too stiff to pour in forms. A mix fluid enough to be poured in forms always contains a certain amount of water over and above that which will combine with the cement. This water eventually evaporates, leaving voids, or pores, in the concrete. Penetration of the concrete by water is still impossible if these voids are not interconnected. They may be interconnected, however, as a result of slight sinking of solid particles in the mix during the hardening period. As these particles sink, they leave water-filled channels that become voids when the water evaporates. The larger and more numerous these voids are, the more the watertightness of the concrete is impaired. The size and number of the voids vary directly with the amount of water used in excess of the amount required to hydrate the cement. To keep the concrete as watertight as possible, you must not use more water than the minimum amount required to attain the necessary degree of workability.

## **GENERAL REQUIREMENTS FOR GOOD CONCRETE**

The first requirement for good concrete is to use a cement type suitable for the work at hand and have a satisfactory supply of sand, coarse aggregate, and water. Everything else being equal, the mix with the best graded, strongest, best shaped, and cleanest aggregate makes the strongest and most durable concrete.

Second, the amount of cement, sand, coarse aggregate, and water required for each batch must be carefully weighed or measured according to project specifications.

Third, even the best designed, best graded, and highest quality mix does not make good concrete if it is not workable enough to fill the form spaces thoroughly. On the other hand, too much fluidity also results in defects. Also, improper handling during the overall concrete making process, from the initial aggregate handling to the final placement of the mix,

causes segregation of aggregate particles by sizes, resulting in nonuniform, poor-quality concrete.

Finally, the best designed, best graded, highest quality, and best placed mix does not produce good concrete if it is not properly cured, that is, properly protected against loss of moisture during the earlier stages of setting.

## **CONCRETE INGREDIENTS**

*LEARNING OBJECTIVE: Upon completing this section, you should be able to identify the ingredients essential for good concrete.*

The essential ingredients of concrete are cement, aggregate, and water. A mixture of only cement and water is called cement paste. In large quantities, however, cement paste is prohibitively expensive for most construction purposes.

## **PORTLAND CEMENT**

Most cement used today is portland cement. This is a carefully proportioned and specially processed combination of lime, silica, iron oxide, and alumina. It is usually manufactured from limestone mixed with shale, clay, or marl. Properly proportioned raw materials are pulverized and fed into kilns where they are heated to a temperature of 2,700°F and maintained at that temperature for a specific time. The heat produces chemical changes in the mixture and transforms it into clinker—a hard mass of fused clay and limestone. The clinker is then ground to a fineness that will pass through a sieve containing 40,000 openings per square inch.

### **Types of Cement**

There are five types of Portland cement covered under “Standard Specifications for Portland Cement.” These specifications are governed by the American Society for Testing and Material (ASTM) types. Separate specifications, such as those required for air-entraining portland cements, are found under a separate ASTM. The type of construction, chemical composition of the soil, economy, and requirements for use of the finished concrete are factors that influence the selection of the kind of cement to be used.

**TYPE I.**— Type I cement is a general-purpose cement for concrete that does not require any of the special properties of the other types. In general, type I cement is intended for concrete that is not subjected

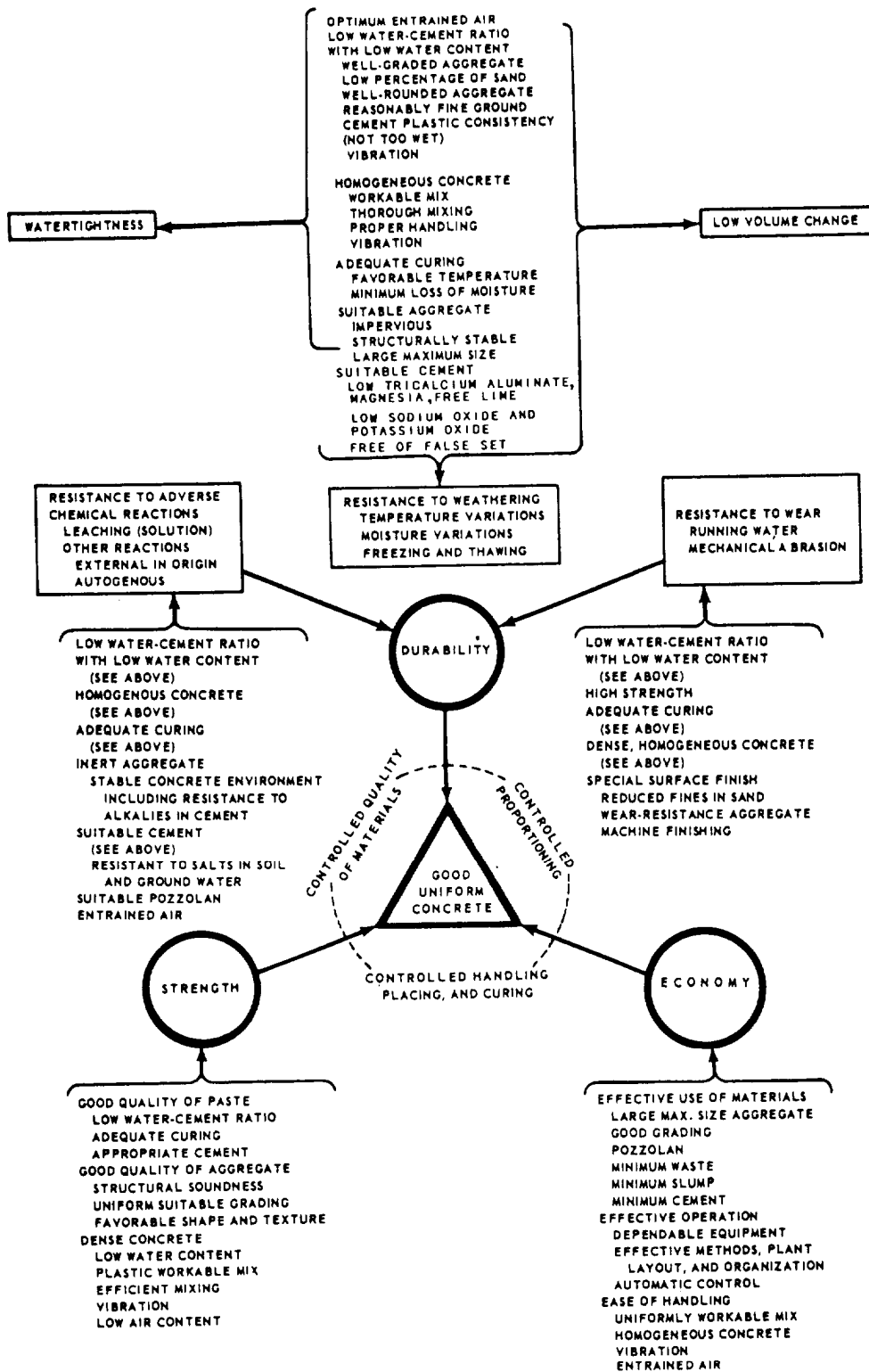

Figure 6-1.—The principal properties of good concrete.

to sulfate attack or damage by the heat of hydration. Type I portland cement is used in pavement and sidewalk construction, reinforced concrete buildings and bridges, railways, tanks, reservoirs, sewers, culverts, water pipes, masonry units, and soil-cement mixtures. Generally, it is more available than the other types. Type I cement reaches its design strength in about 28 days.

**TYPE II.**— Type II cement is modified to resist moderate sulfate attack. It also usually generates less heat of hydration and at a slower rate than type I. A typical application is for drainage structures where the sulfate concentrations in either the soil or groundwater are higher than normal but not severe. Type II cement is also used in large structures where its moderate heat of hydration produces only a slight temperature rise in the concrete. However, the temperature rise in type II cement can be a problem when concrete is placed during warm weather. Type II cement reaches its design strength in about 45 days.

**TYPE III.**— Type III cement is a high-early-strength cement that produces design strengths at an early age, usually 7 days or less. It has a higher heat of hydration and is more finely ground than type I. Type III permits fast form removal and, in cold weather construction, reduces the period of protection against low temperatures. Richer mixtures of type I can obtain high early strength, but type III produces it more satisfactorily and economically. However, use it cautiously in concrete structures having a minimum dimension of 2 1/2 feet or more. The high heat of hydration can cause shrinkage and cracking.

**TYPE IV.**— Type IV cement is a special cement. It has a low heat of hydration and is intended for applications requiring a minimal rate and amount of heat of hydration. Its strength also develops at a slower rate than the other types. Type IV is used primarily in very large concrete structures, such as gravity dams, where the temperature rise from the heat of hydration might damage the structure. Type IV cement reaches its design strength in about 90 days.

**TYPE V.**— Type V cement is sulfate-resistant and should be used where concrete is subjected to severe sulfate action, such as when the soil or groundwater contacting the concrete has a high sulfate content. Type V cement reaches its design strength in about 60 days.

## **Air-Entrained Cement**

Air-entrained portland cement is a special cement that can be used with good results for a variety of conditions. It has been developed to produce concrete that is resistant to freeze-thaw action, and to scaling caused by chemicals applied for severe frost and ice removal. In this cement, very small quantities of air-entraining materials are added as the clinker is being ground during manufacturing. Concrete made with this cement contains tiny, well-distributed and completely separated air bubbles. The bubbles are so small that there may be millions of them in a cubic foot of concrete. The air bubbles provide space for freezing water to expand without damaging the concrete. Air-entrained concrete has been used in pavements in the northern states for about 25 years with excellent results. Air-entrained concrete also reduces both the amount of water loss and the capillary/water-channel structure.

An air-entrained admixture may also be added to types I, II, and III portland cement. The manufacturer specifies the percentage of air entrainment that can be expected in the concrete. An advantage of using air-entrained cement is that it can be used and batched like normal cement. The air-entrained admixture comes in a liquid form or mixed in the cement. To obtain the proper mix, you should add the admixture at the batch plant.

## **AGGREGATES**

The material combined with cement and water to make concrete is called aggregate. Aggregate makes up 60 to 80 percent of concrete volume. It increases the strength of concrete, reduces the shrinking tendencies of the cement, and is used as an economical filler.

### **Types**

Aggregates are divided into fine (usually consisting of sand) and coarse categories. For most building concrete, the coarse aggregate consists of gravel or crushed stone up to 1 1/2 inches in size. However, in massive structures, such as dams, the coarse aggregate may include natural stones or rocks ranging up to 6 inches or more in size.



## Purpose of Aggregates

The large, solid coarse aggregate particles form the basic structural members of the concrete. The voids between the larger coarse aggregate particles are filled by smaller particles. The voids between the smaller particles are filled by still smaller particles. Finally, the voids between the smallest coarse aggregate particles are filled by the largest fine aggregate particles. In turn, the voids between the largest fine aggregate particles are filled by smaller fine aggregate particles, the voids between the smaller fine aggregate particles by still smaller particles, and soon. Finally, the voids between the finest grains are filled with cement. You can see from this that the better the aggregate is graded (that is, the better the distribution of particles sizes), the more solidly all voids will be filled, and the denser and stronger will be the concrete.

The cement and water form a paste that binds the aggregate particles solidly together when it hardens. In a well-graded, well-designed, and well-mixed batch, each aggregate particle is thoroughly coated with the cement-water paste. Each particle is solidly bound to adjacent particles when the cement-water paste hardens.

**AGGREGATE SIEVES.**— The size of an aggregate sieve is designated by the number of meshes to the linear inch in that sieve. The higher the number, the finer the sieve. Any material retained on the No. 4 sieve can be considered either coarse or fine. Aggregates huger than No. 4 are all course; those smaller are all fines. No. 4 aggregates are the dividing point. The finest coarse-aggregate sieve is the same No. 4 used as the coarsest fine-aggregate

sieve. With this exception, a coarse-aggregate sieve is designated by the size of one of its openings. The sieves commonly used are 1 1/2 inches, 3/4 inch, 1/2 inch, 3/8 inch, and No. 4. Any material that passes through the No. 200 sieve is too fine to be used in making concrete.

**PARTICLE DISTRIBUTION.**— Experience and experiments show that for ordinary building concrete, certain particle distributions consistently seem to produce the best results. For fine aggregate, the recommended distribution of particle sizes from No. 4 to No. 100 is shown in table 6-1.

The distribution of particle sizes in aggregate is determined by extracting a representative sample of the material, screening the sample through a series of sieves ranging in size from coarse to fine, and determining the percentage of the sample retained on each sieve. This procedure is called making a sieve analysis. For example, suppose the total sample weighs 1 pound. Place this on the No. 4 sieve, and shake the sieve until nothing more goes through. If what is left on the sieve weighs 0.05 pound, then 5 percent of the total sample is retained on the No. 4 sieve. Place what passes through on the No. 8 sieve and shake it. Suppose you find that what stays on this sieve weighs 0.1 pound. Since 0.1 pound is 10 percent of 1 pound, 10 percent of the total sample was retained on the No. 8 sieve. The cumulative retained weight is 0.15 pound. By dividing 0.15 by 1.0 pound, you will find that the total retained weight is 15 percent.

The size of coarse aggregate is usually specified as a range between a minimum and a maximum size; for example, 2 inches to No. 4, 1 inch to No. 4,

Table 6-1.—Recommended Distribution of Particle Sizes

SIEVE NUMBER	PERCENT RETAINED ON SQUARE MESH LABORATORY SIEVES
3/8"	0
No. 4	18
No. 8	27
No. 16	20
No. 30	20
No. 50	10
No. 100	4

Table 6-2.—Recommended Maximum and Minimum Particle Sizes

SIZE OF COURSE AGGREGATE, IN INCHES	PERCENTAGES BY WEIGHT PASSING LABORATORY SIEVES HAVING SQUARE OPENINGS										
	4-in.	3 1/2 in.	3-in.	2 1/2 in.	2-in.	1 1/2 in.	1-in.	3/4 in.	1/2 in.	3/8 in.	No. 4
1.5	—	—	—	—	100	95-100	—	35-70	—	10-30	0-5
2	—	—	—	100	95-100	—	35-70	—	10-30	—	0-5
2.5	—	—	100	90-100	—	35-70	—	10-40	—	0-15	0-5
3.5	100	90-100	—	45-80	—	25-50	—	10-30	—	0-15	0-5

2 inches to 1 inch, and so on. The recommended particle size distributions vary with maximum and minimum nominal size limits, as shown in table 6-2.

A blank space in table 6-2 indicates a sieve that is not required in the analysis. For example, for the 2 inch to No. 4 nominal size, there are no values listed under the 4-inch, the 3 1/2-inch, the 3-inch, and the 2 1/2-inch sieves. Since 100 percent of this material should pass through a 2 1/2-inch sieve, there is no need to use a sieve coarser than that size. For the same size designation (that is, 2 inch size aggregate), there are no values listed under the 1 1/2-inch, the 3/4-inch, and the 3/8-inch sieves. Experience has shown that it is not necessary to use these sieves in making this particular analysis.

**Quality Standards**

Since 66 to 78 percent of the volume of the finished concrete consists of aggregate, it is imperative that the aggregate meet certain minimum quality standards. It should consist of clean, hard, strong, durable particles free of chemicals that might interfere with hydration. The aggregate should also be free of any superfine material, which might prevent a bond between the aggregate and the cement-water paste. The undesirable substances most frequently found in aggregate are dirt, silt, clay, coal, mica, salts, and organic matter. Most of these can be removed by washing. Aggregate can be field-tested for an excess of silt, clay, and the like, using the following procedure:

1. Fill a quart jar with the aggregate to a depth of 2 inches.

2. Add water until the jar is about three-fourths full.
3. Shake the jar for 1 minute, then allow it to stand for 1 hour.
4. If, at the end of 1 hour, more than 1/8 inch of sediment has settled on top of the aggregate, as shown in figure 6-2, the material should be washed.

An easily constructed rig for washing a small amount of aggregate is shown in figure 6-3.

Weak, friable (easily pulverized), or laminated (layered) aggregate particles are undesirable. Especially avoid shale, stones laminated with shale, and most varieties of chert (impure flint-like rock). For most ordinary concrete work, visual inspection is enough to reveal any weaknesses in the coarse

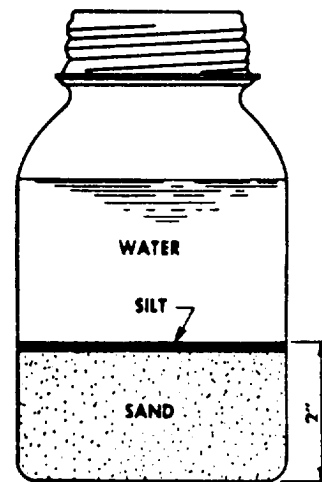

Figure 6-2.—Quart jar method of determining silt content of sand.

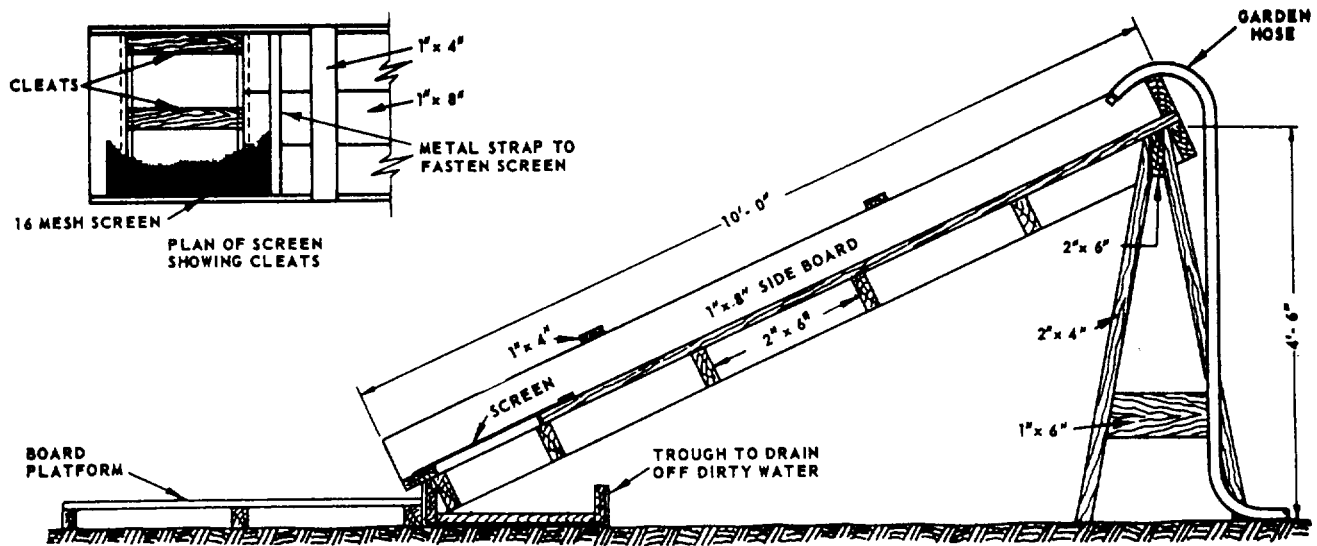

Figure 6-3.-Field-constructed rig for washing aggregate.

aggregate. For work in which aggregate strength and durability are of vital importance, such as paving concrete, aggregate must be laboratory tested.

### Handling and Storage

A mass of aggregate containing particles of different sizes has a natural tendency toward segregation. "Segregation" refers to particles of the same size tending to gather together when the material is being loaded, transported, or otherwise disturbed. Aggregate should always be handled and stored by a method that minimizes segregation.

Stockpiles should not be built up in cone shapes, formed by dropping successive loads at the same spot. This procedure causes segregation. A pile should be built up in layers of uniform thickness, each made by dumping successive loads alongside each other.

If aggregate is dropped from a clamshell, bucket, or conveyor, some of the fine material may be blown aside, causing a segregation of fines on the lee side (that is, the side away from the wind) of the pile. Conveyors, clamshells, and buckets should be discharged in contact with the pile.

When a bin is being charged (filled), the material should be dropped from a point directly over the outlet. Material chuted in at an angle or material discharged against the side of a bin will segregate. Since a long drop will cause both segregation and the breakage of aggregate particles, the length of a drop into a bin should be minimized by keeping the bin as full as possible at all times. The bottom of a storage bin should always slope at least 50° toward the central

outlet. If the slope is less than 50°, segregation will occur as material is discharged out of the bin.

### WATER

The two principal functions of water in a concrete mix are to effect hydration and improve workability. For example, a mix to be poured in forms must contain more water than is required for complete hydration of the cement. Too much water, however, causes a loss of strength by upsetting the water-cement ratio. It also causes "water-gain" on the surface—a condition that leaves a surface layer of weak material, called laitance. As previously mentioned, an excess of water also impairs the watertightness of the concrete.

Water used in mixing concrete must be clean and free from acids, alkalis, oils, and organic materials. Most specifications recommend that the water used in mixing concrete be suitable for drinking, should such water be available.

Seawater can be used for mixing unreinforced concrete if there is a limited supply of fresh water. Tests show that the compressive strength of concrete made with seawater is 10 to 30 percent less than that obtained using fresh water. Seawater is not suitable for use in making steel-reinforced concrete because of the risk of corrosion of the reinforcement, particularly in warm and humid environments.

### ADMIXTURES

Admixtures include all materials added to a mix other than portland cement, water, and aggregates.

Admixtures are sometimes used in concrete mixtures to improve certain qualities, such as workability, strength, durability, watertightness, and wear resistance. They may also be added to reduce segregation, reduce the heat of hydration, entrain air, and accelerate or retard setting and hardening.

We should note that the same results can often be obtained by changing the mix proportions or by selecting other suitable materials without resorting to the use of admixtures (except air-entraining admixtures when necessary). Whenever possible, comparison should be made between these alternatives to determine which is more economical or convenient. Any admixture should be added according to current specifications and under the direction of the crew leader.

### **Workability Agents**

Materials, such as hydrated lime and bentonite, are used to improve workability. These materials increase the fines in a concrete mix when an aggregate is tested deficient in fines (that is, lacks sufficient fine material).

### **Air-Entraining Agents**

The deliberate adding of millions of minute disconnected air bubbles to cement paste, if evenly diffused, changes the basic concrete mix and increases durability, workability, and strength. The acceptable amount of entrained air in a concrete mix, by volume, is 3 to 7 percent. Air-entraining agents, used with types I, II, or III cement, are derivatives of natural wood resins, animal or vegetable fats, oils, alkali salts of sulfated organic compounds, and water-soluble soaps. Most air-entraining agents are in liquid form for use in the mixing water.

### **Accelerator**

The only accepted accelerator for general concrete work is calcium chloride with not more than 2 percent by weight of the cement being used. This accelerator is added as a solution to the mix water and is used to speed up the strength gain. Although the final strength is not affected, the strength gain for the first 7 days is greatly affected. The strength gain for the first 7 days can be as high as 1,000 pounds per square inch (psi) over that of normal concrete mixes.

### **Retarders**

The accepted use for retarders is to reduce the rate of hydration. This permits the placement and

consolidation of concrete before initial set. Agents normally used are fatty acids, sugar, and starches.

## **CEMENT STORAGE**

Portland cement is packed in cloth or paper sacks, each weighing 94 pounds. A 94-pound sack of cement amounts to about 1 cubic foot by loose volume.

Cement will retain its quality indefinitely if it does not come in contact with moisture. If allowed to absorb appreciable moisture in storage, however, it sets more slowly and strength is reduced. Sacked cement should be stored in warehouses or sheds made as watertight and airtight as possible. All cracks in roofs and walls should be closed, and there should be no openings between walls and roof. The floor should be above ground to protect the cement against dampness. All doors and windows should be kept closed.

Sacks should be stacked against each other to prevent circulation of air between them, but they should not be stacked against outside walls. If stacks are to stand undisturbed for long intervals, they should be covered with tarpaulins.

When shed or warehouse storage cannot be provided, sacks that must be stored in the open should be stacked on raised platforms and covered with waterproof tarps. The tarps should extend beyond the edges of the platform to deflect water away from the platform and the cement.

Cement sacks stacked in storage for long periods sometimes acquire a hardness called warehouse pack. This can usually be loosened by rolling the sack around. However, cement that has lumps or is not free flowing should not be used.

## **CONCRETE MIX DESIGN**

*LEARNING OBJECTIVE: Upon completing this section, you should be able to calculate concrete mix designs.*

Before proportioning a concrete mix, you need information concerning the job, such as size and shapes of structural members, required strength of the concrete, and exposure conditions. The end use of the concrete and conditions at time of placement are additional factors to consider.

## **INGREDIENT PROPORTIONS**

The ingredient proportions for the concrete on a particular job are usually set forth in the specifications under "CONCRETE—General Requirements." See table 6-3 for examples of normal

Table 6-3.-Normal Concrete

CLASS OF CONCRETE (FIGURES DENOTE SIZE OF COARSE AGGREGATE IN INCHES)	ESTIMATED 28-DAY COMPRESSIVE STRENGTH (POUNDS PER SQUARE INCH)	CEMENT FACTOR BAGS (94 POUNDS) OF CEMENT PER CUBIC YARD OF CONCRETE FRESHLY MIXED	MAXIMUM WATER (GALLONS) PER BAG (94 POUNDS) OF CEMENT	FINE AGGREGATE RANGE IN PERCENT OF TOTAL AGGREGATE BY WEIGHT	APPROXIMATE WEIGHTS OF SATURATED SURFACE-DRY AGGREGATES PER BAG (94 POUNDS) OF CEMENT	
					FINE AGGREGATE POUNDS	COURSE AGGREGATE POUNDS
(1)	(2)	(3)	(4)	(5)	(6)	(7)
B-1	1,500	4.10	9.50	42-52	368	415
B1-1.5	1,500	3.80	9.50	38-48	376	498
B-2	1,500	3.60	9.50	35-45	378	567
B-2.5	1,500	3.50	9.50	33-43	373	609
B-3.5	1,500	3.25	9.50	30-40	378	702
C-1	2,000	4.45	8.75	41-51	329	387
C-1.5	2,000	4.10	8.75	37-47	338	467
C-2	2,000	3.90	8.75	34-44	338	529
C-2.5	2,000	3.80	8.75	32-42	332	565
C-3.5	2,000	3.55	8.75	29-39	334	648
D-0.5	2,500	5.70	7.75	50-60	282	231
D-0.75	2,500	5.30	7.75	45-55	288	288
D-1	2,500	5.05	7.75	40-50	279	341
D-1.5	2,500	4.65	7.75	36-46	287	413
D-2	2,500	4.40	7.75	34-42	288	471
D-2.5	2,500	4.25	7.75	32-40	287	509
D-3.5	2,500	4.00	7.75	29-37	285	578
E-0.5	3,000	6.50	6.75	50-58	238	203
E-0.75	3,000	6.10	6.75	45-53	240	249
E-1	3,000	5.80	6.75	40-48	233	297
E-1.5	3,000	5.35	6.75	36-44	239	359
E-2	3,000	5.05	6.75	33-41	241	410
E-2.5	3,000	4.90	6.75	31-39	238	441
E-3.5	3,000	4.60	6.75	28-36	237	503
F-0.375	3,500	7.70	6.00	56-64	210	140
F-0.5	3,500	7.35	6.00	48-56	198	183
F-0.75	3,500	6.85	6.00	43-51	201	226
F-1	3,500	6.50	6.00	38-46	195	270
F-1.5	3,500	6.00	6.00	34-42	200	325
F-2	3,500	5.70	6.00	31-29	199	369
F-2.5	3,500	5.50	6.00	29-37	197	400
F-3.5	3,500	5.20	6.00	27-35	200	444
G-0.25	4,000	8.95	5.50	100	281	—
G-0.375	4,000	8.40	5.50	55-63	186	129
G-0.5	4,000	8.00	5.50	47-55	175	168
G-0.75	4,000	7.45	5.50	42-50	178	209
G-1	4,000	7.10	5.50	37-45	172	247
G-1.5	4,000	6.55	5.50	33-41	175	299
G-2	4,000	6.20	5.50	30-38	175	340
G-2.5	4,000	6.00	5.50	28-36	173	368
G-3.5	4,000	5.65	5.50	26-34	176	411
H-0.25	5,000	11.50	4.25	100	202	—
H-0.375	5,000	10.80	4.25	53-61	130	98
H-0.5	5,000	10.35	4.25	45-53	121	126
H-0.75	5,000	9.65	4.25	40-48	123	157
H-1	5,000	9.20	4.25	35-43	119	186
H-1.5	5,000	8.45	4.25	31-39	122	228
H-2	5,000	8.00	4.25	28-36	122	260

concrete-mix design according to NAVFAC specifications.

In table 6-3, one of the formulas for 3,000 psi concrete is 5.80 bags of cement per cubic yard, 233 pounds of sand (per bag of cement), 297 pounds of coarse aggregate (per bag of cement), and a water-cement ratio of 6.75 gallons of water to each bag of cement. These proportions are based on the assumption that the inert ingredients are in a saturated surface-dry condition, meaning that they contain all the water they are capable of absorbing, but no additional free water over and above this amount.

We need to point out that a saturated surface-dry condition almost never exists in the field. The amount of free water in the coarse aggregate is usually small enough to be ignored, but the ingredient proportions set forth in the specs must almost always be adjusted to allow for the existence of free water in the fine aggregate. Furthermore, since free water in the fine aggregate increases its measured volume or weight over that of the sand itself, the specified volume or weight of sand must be increased to offset the volume or weight of the water in the sand. Finally, the number of gallons of water used per sack of cement must be reduced to allow for the free water in the sand. The amount of water actually added at the mixer must be the specified amount per sack, less the amount of free water that is already in the ingredients in the mixer.

Except as otherwise specified in the project specifications, concrete is proportioned by weighing and must conform to NAVFAC specifications. (See table 6-3 for normal concrete.)

## **MATERIAL ESTIMATES**

When tables, such as table 6-3, are not available for determining quantities of material required for 1 cubic yard of concrete, a rule of thumb, known as rule 41 or 42, may be used for a rough estimation. According to this rule, it takes either 41 or 42 cubic feet of the combined dry amounts of cement, sand, and aggregates to produce 1 cubic yard of mixed concrete. Rule 41 is used to calculate the quantities of material for concrete when the size of the coarse aggregate is not over 1 inch. Rule 42 is used when the size of the coarse aggregate is not over 2 1/2 inches. Here is how it works.

As we mentioned earlier, a bag of cement contains 94 pounds by weight, or about 1 cubic foot by loose volume. A batch formula is usually based on

the number of bags of cement used in the mixing machine.

For estimating the amount of dry materials needed to mix 1 cubic yard of concrete, rules 41 and 42 work in the same manner. The decision on which rule to use depends upon the size of the aggregate. Let's say your specifications call for a 1:2:4 mix with 2-inch coarse aggregates, which means you use rule 42. First, add 1:2:4, which gives you 7. Then compute your material requirements as follows:

$$42 + 7 = 6 \text{ bags, or } 6 \text{ cu ft of cement;}$$

$$6 \times 2 = 12 \text{ cu ft of sand;}$$

$$6 \times 4 = 24 \text{ cu ft of coarse aggregates.}$$

Adding your total dry materials,  $6 + 12 + 24 = 42$ , so your calculations are correct.

Frequently, you will have to convert volumes in cubic feet to weights in pounds. In converting, multiply the required cubic feet of cement by 94 since 1 cubic foot, or 1 standard bag of cement, weighs 94 pounds. When using rule 41 for coarse aggregates, multiply the quantity of coarse gravel in cubic feet by 105 since the average weight of dry-compacted fine aggregate or gravel is 105 pounds per cubic feet. By rule 42, however, multiply the cubic feet of rock (1-inch-size coarse aggregate) by 100 since the average dry-compacted weight of this rock is 100 pounds per cubic foot.

A handling-loss factor is added in ordering materials for jobs. An additional 5 percent of materials is added for jobs requiring 200 or more cubic yards of concrete, and 10 percent is added for smaller jobs. This loss factor is based on material estimates after the requirements have been calculated. Additional loss factors may be added where conditions indicate the necessity for excessive handling of materials before batching.

## **Measuring Water**

The water-measuring controls on a machine concrete mixer are described later in this chapter. Water measurement for hand mixing can be done with a 14-quart bucket, marked off on the inside in gallons, half-gallons, and quarter-gallons.

Never add water to the mix without carefully measuring the water, and always remember that the amount of water actually placed in the mix varies according to the amount of free water that is already in the aggregate. This means that if the aggregate is

wet by a rainstorm, the proportion of water in the mix may have to be changed.

### Measuring Aggregate

The accuracy of aggregate measurement by volume depends upon the accuracy with which the amount of "bulking," caused by moisture in the aggregate, can be determined. The amount of bulking varies not only with different moisture contents but also with different gradations. Fine sand, for example, is bulked more than coarse sand by the same moisture content. Furthermore, moisture content itself varies from time to time, and a small variation causes a large change in the amount of bulking. For these and other reasons, aggregate should be measured by weight rather than by volume whenever possible.

To make grading easier, to keep segregation low, and to ensure that each batch is uniform, you should store and measure coarse aggregate from separate piles or hoppers. The ratio of maximum to minimum particle size should not exceed 2:1 for a maximum nominal size larger than 1 inch. The ratio should not exceed 3:1 for a maximum nominal size smaller than 1 inch. A mass of aggregate with a nominal size of 1 1/2 inches to 1/4 inch, for example, should be separated into one pile or hopper containing 1 1/2-inch to 3/4-inch aggregate, and another pile or hopper containing 3/4-inch to 1/4-inch aggregate. A mass with a nominal size of 3 inches to 1/4 inch should be separated into one pile or hopper containing 3-inch to 1 1/2-inch aggregate, another containing 1 1/2-inch to 3/4-inch aggregate, and a third containing 3/4-inch to 1/4-inch aggregate.

### Water-Cement Ratio

The major factor controlling strength, everything else being equal, is the amount of water used per bag of cement. Maximum strength is obtained by using just the amount of water, and no more, required for the complete hydration of the cement. As previously mentioned, however, a mix of this type maybe too dry to be workable. Concrete mix always contains more water than the amount required to attain maximum strength. The point for you to remember is that the strength of concrete decreases as the amount of extra water increases.

The specified water-cement ratio is the happy medium between the maximum possible strength of the concrete and the necessary minimum workability

requirements. The strength of building concrete is expressed in terms of the compressive strength in pounds per square inch (psi) reached after a 7- or 28-day set. This is usually referred to as "probable average 7-day strength" and "probable average 28-day strength."

### SLUMP TESTING

Slump testing is a means of measuring the consistency of concrete using a "slump cone." The cone is made of galvanized metal with an 8-inch-diameter base, a 4-inch-diameter top, and a 12-inch height. The base and the top are open and parallel to each other and at right angles to the axis of the cone (figure 6-4). A tamping rod 5/8 inch in diameter and 24 inches long is also needed. The tamping rod should be smooth and bullet-pointed. Do not use a piece of reinforcing bar (rebar).

Samples of concrete for test specimens are taken at the mixer or, in the case of ready-mixed concrete, from the transportation vehicle during discharge. The sample of concrete from which test specimens are made should be representative of the entire batch. Such samples are obtained by repeatedly passing a scoop or pail through the discharging stream of concrete, starting the sampling operation at the beginning of discharge, and repeating the operation until the entire batch is discharged. To counteract segregation when a sample must be transported to a test site, the concrete should be remixed with a shovel until it is uniform in appearance. The job location from which the sample was taken should be noted for future reference. In the case of paving concrete,

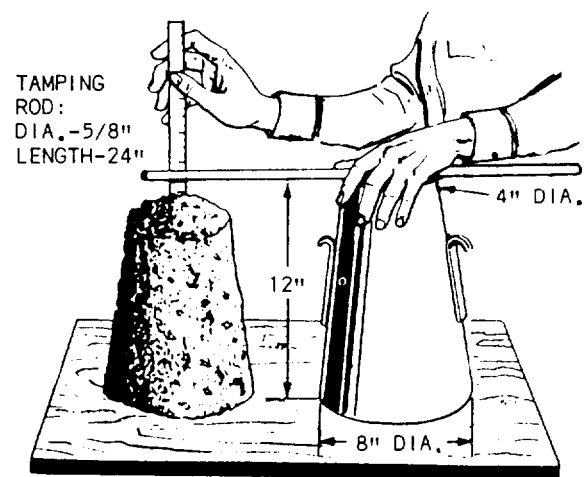

Figure 6-4.-Measurement of slump.

samples may be taken from the batch immediately after depositing it on the subgrade. At least five samples should be taken at different times, and these samples should be thoroughly mixed to form the test specimen.

When making a slump test, dampen the cone and place it on a flat, moist, nonabsorbent surface. From the sample of concrete obtained, immediately fill the cone in three layers, each approximately one-third the volume of the cone. In placing each scoop full of concrete in the cone, move the scoop around the edge of the cone as the concrete slides from the scoop. This ensures symmetrical distribution of concrete within the cone. Each layer is then “rodded in” with 25 strokes. The strokes should be distributed uniformly over the cross section of the cone and penetrate into the underlying layer. The bottom layer should be rodded throughout its depth.

If the cone becomes overfilled, use a straightedge to strike off the excess concrete flush with the top. The cone should be immediately removed from the concrete by raising it carefully in a vertical direction. The slump should be measured immediately after removing the cone. You determine the slump by measuring the difference between the height of the cone and the height of the specimen (figure 6-4). The slump should be recorded in terms of inches of subsidence of the specimen during the test.

After completing the slump measurement, gently tap the side of the mix with the tamping rod. The behavior of the concrete under this treatment is a valuable indication of the cohesiveness, workability, and placability of the mix. In a well-proportioned mix, tapping only causes it to slump lower. It doesn't crumble apart or segregate by the dropping of larger aggregate particles to a lower level in the mix. If the concrete crumbles apart, it is oversanded. If it segregates, it is undersanded.

## **WORKABILITY**

A mix must be workable enough to fill the form spaces completely, with the assistance of a reasonable amount of shoveling, spading, and vibrating. Since a fluid or “runny” mix does this more readily than a dry or “stiff” mix, you can see that workability varies directly with fluidity. The workability of a mix is determined by the slump test. The amount of the slump, in inches, is the measure of the concrete's workability—the more the slump, the higher the workability.

The slump can be controlled by a change in any one or all of the following: gradation of aggregates, proportion of aggregates, or moisture content. If the moisture content is too high, you should add more cement to maintain the proper water-cement ratio.

The desired degree of workability is attained by running a series of trial batches, using various amounts of fine to coarse aggregate, until a batch is produced that has the desired slump. Once the amount of increase or decrease in fines required to produce the desired slump is determined, the aggregate proportions, not the water proportion, should be altered in the field mix to conform. If the water proportion were changed, the water-cement ratio would be upset.

Never yield to the temptation to add more water without making the corresponding adjustment in the cement content. Also, make sure that crewmembers who are spreading a stiff mix by hand do not ease their labors by this method without telling you.

As you gain experience, you will discover that adjustments in workability can be made by making very minor changes in the amount of fine or coarse aggregate. Generally, everything else remaining equal, an increase in the proportion of fines stiffens a mix, whereas an increase in the proportion of coarse loosens a mix.

## **NOTE**

Before you alter the proportions set forth in a specification, you must find out from higher authority whether you are allowed to make any such alterations and, if you are, the permissible limits beyond which you must not go.

## **GROUT**

As previously mentioned, concrete consists of four essential ingredients: water, cement, sand, and coarse aggregate. The same mixture without aggregate is mortar. Mortar, which is used chiefly for bonding masonry units together, is discussed in a later chapter. Grout refers to a water-cement mixture called neat-cement grout and to a water-sand-cement mixture called sand-cement grout. Both mixtures are used to plug holes or cracks in concrete, to seal joints, to fill spaces between machinery bedplates and concrete foundations, and for similar plugging or sealing purposes. The consistency of grout may range from stiff (about 4 gallons of water per sack of



cement) to fluid (as many as 10 gallons of water per sack of cement), depending upon the nature of the grouting job at hand.

## BATCHING

When bagged cement is used, the field mix proportions are usually given in terms of designated amounts of fine and coarse aggregate per bag (or per 94 pounds) of cement. The amount of material that is mixed at a time is called a batch. The size of a batch is usually designated by the number of bags of cement it contains, such as a four-bag batch, a six-bag batch, and so forth.

The process of weighing out or measuring out the ingredients for a batch of concrete is called batching. When mixing is to be done by hand, the size of the batch depends upon the number of persons available to turn it with hand tools. When mixing is to be done by machine, the size of the batch depends upon the rated capacity of the mixer. The rated capacity of a mixer is given in terms of cubic feet of mixed concrete, not of dry ingredients.

On large jobs, the aggregate is weighed out in an aggregate batching plant (usually shortened to "batch plant"), like the one shown in figure 6-5. Whenever possible, a batch plant is located near to and used in conjunction with a crushing and screening plant. In a crushing and screening

plant, stone is crushed into various particle sizes, which are then screened into separate piles. In a screening plant, the aggregate in its natural state is screened by sizes into separate piles.

The batch plant, which is usually portable and can be taken apart and moved from site to site, is generally set up adjacent to the pile of screened aggregate. The plant may include separate hoppers for several sizes of fine and coarse aggregates, or only one hopper for fine aggregate and another for coarse aggregate. It may have one or more divided hoppers, each containing two or more separate compartments for different sizes of aggregates.

Each storage hopper or storage hopper compartment can be discharged into a weigh box, which can, in turn, be discharged into a mixer or a batch truck. When a specific weight of aggregate is called for, the operator sets the weight on a beam scale. The operator then opens the discharge chute on the storage hopper. When the desired weight is reached in the weigh box, the scale beam rises and the operator closes the storage hopper discharge chute. The operator then opens the weigh box discharge chute, and the aggregate discharges into the mixer or batch truck. Batch plant aggregate storage hoppers are usually loaded with clamshell-equipped cranes.

The following guidelines apply to the operation of batch plants:

- All personnel working in the batch plant area should wear hard hats at all times.
- While persons are working in conveyor line areas, the switches and controls should be secured and tagged so that no one can engage them until all personnel are clear.
- When hoppers are being loaded, personnel should stay away from the area of falling aggregate.
- The scale operator should be the only person on the scale platform during batching operations.
- Housekeeping of the charging area is important. Personnel should do everything possible to keep the area clean and free of spoiled material or overflow.
- Debris in aggregate causes much of the damage to conveyors. Keep the material clean at all times.



29.153

Figure 6-5.-Aggregate batching plant

- When batch operations are conducted at night, good lighting is a must.
- Personnel working in batch plants should use good eye hygiene. Continual neglect of eye care can have serious consequences.

### MIXING CONCRETE

*LEARNING OBJECTIVE: Upon completing this section, you should be able to determine methods and mixing times of concrete.*

Concrete is mixed either by hand or machine. No matter which method is used, you must follow well-established procedures if you expect finished concrete of good quality. An oversight in proper concrete mixing, whether through lack of competence or inattention to detail, cannot be corrected later.

#### MIXING BY HAND

A batch to be hand mixed by a couple of crewmembers should not be much larger than 1 cubic yard. The equipment required consists of a watertight metal or wooden platform, two shovels, a metal-lined measuring box, and a graduated bucket for measuring the water.

The mixing platform does not need to be made of expensive materials. It can be an abandoned concrete slab or concrete parking lot that can be cleaned after use. A wooden platform having tight joints to prevent the loss of paste may be used. Whichever surface is used, you should ensure that it is cleaned prior to use and level.

Let's say your batch consists of two bags of cement, 5.5 cubic feet of sand, and 6.4 cubic feet of coarse aggregate. Mix the sand and cement together first, using the following procedure:

1. Dump 3 cubic feet of sand on the platform first, spread it out in a layer, and dump a bag of cement over it.
2. Spread out the cement and dump the rest of the sand (2.5 cubic feet) over it.
3. Dump the second sack of cement on top of the lot.

This use of alternate layers of sand and cement reduces the amount of shoveling required for complete mixing.

Personnel doing the mixing should face each other from opposite sides of the pile and work from the outside to the center. They should turn the mixture as many times as is necessary to produce a uniform color throughout. When the cement and sand are completely mixed, the pile should be leveled off and the coarse material added and mixed by the same turning method.

The pile should next be troughed in the center. The mixing water, after being carefully measured, should be poured into the trough. The dry materials should then be turned into the water, with great care taken to ensure that none of the water escapes. When all the water has been absorbed, the mixing should continue until the mix is of a uniform consistency. Four complete turnings are usually required.

#### MIXING BY MACHINE

The size of a concrete mixer is designated by its rated capacity. As we mentioned earlier, the capacity is expressed in terms of the volume of mixed concrete, not of dry ingredients the machine can mix in a single batch. Rated capacities run from as small as 2 cubic feet to as large as 7 cubic yards (189 cubic feet). In the Naval Construction Forces (NCFs), the most commonly used mixer is the self-contained Model 16-S (figure 6-6) with a capacity of 16 cubic feet (plus a 10-percent overload).

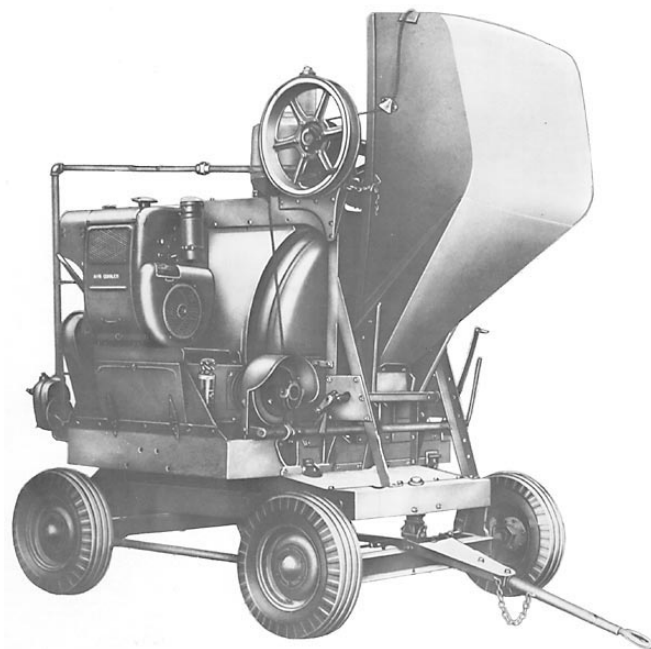

29.151

**Figure 6-6.-Model 16-S concrete mixer.**

The production capacity of the 16-S mixer varies between 5 and 10 cubic yards per hour, depending on the efficiency of the personnel. Aggregate larger than 3 inches will damage the mixer. The mixer consists of a frame equipped with wheels and towing tongue (for easy movement), an engine, a power loader skip, mixing drum, water tank, and an auxiliary water pump. The mixer may be used as a central mixing plant.

### **Charging the Mixer**

Concrete mixers may be charged by hand or with the mechanical skip. Before loading the mechanical skip, remove the towing tongue. Then cement, sand, and gravel are loaded and dumped into the mixer together while the water runs into the mixing drum on the side opposite the skip. A storage tank on top of the mixer measures the mixing water into the drum a few seconds before the skip dumps. This discharge also washes down the mixer between batches. The coarse aggregate is placed in the skip first, the cement next, and the sand is placed on top to prevent excessive loss of cement as the batch enters the mixer.

### **Mixing Time**

It takes a mixing machine having a capacity of 27 cubic feet or larger 1 1/2 minutes to mix a 1-cubic yard batch. Another 15 seconds should be allowed for each additional 1/2 cubic yard or fraction thereof. The water should be started into the drum a few seconds before the skip begins to dump, so that the inside of the drum gets a washout before the batched ingredients go in. The mixing period should be measured from the time all the batched ingredients are in, provided that all the water is in before one-fourth of the mixing time has elapsed. The time elapsing between the introduction of the mixing water to the cement and aggregates and the placing of the concrete in the forms should not exceed 1 1/2 hours.

### **Discharging the Mixer**

When the material is ready for discharge from the mixer, the discharge chute is moved into place to receive the concrete from the drum of the mixer. In some cases, stiff concrete has a tendency to carry up to the top of the drum and not drop down in time to be deposited on the chute. Very wet concrete may not carry up high enough to be caught by the chute. This condition can be corrected by adjusting the speed of the mixer. For very wet concrete, the speed of the

drum should be increased. For stiff concrete, the drum speed should be slowed down,

### **Cleaning and Maintaining the Mixer**

The mixer should be cleaned daily when it is in continuous operation or following each period of use if it is in operation less than a day. If the outside of the mixer is kept coated with oil, the cleaning process can be speeded up. The outside of the mixer should be washed with a hose, and all accumulated concrete should be knocked off. If the blades of the mixer become worn or coated with hardened concrete, the mixing action will be less efficient. Badly worn blades should be replaced. Hardened concrete should not be allowed to accumulate in the mixer drum. The mixer drum must be cleaned out whenever it is necessary to shut down for more than 1 1/2 hours. Place a volume of coarse aggregate in the drum equal to one-half of the capacity of the mixer and allow it to revolve for about 5 minutes. Discharge the aggregate and flush out the drum with water. Do not pound the discharge chute, drum shell, or the skip to remove aggregate or hardened concrete. Concrete will readily adhere to the dents and bumps created. For complete instructions on the operation, adjustment, and maintenance of the mixer, study the manufacturer's manual.

All gears, chains, and rollers of mixers should be properly guarded. All moving parts should be cleaned and properly serviced to permit safe performance of the equipment. When the mixer drum is being cleaned, the switches must be open, the throttles closed, and the control mechanism locked in the OFF position. The area around the mixer must be kept clear.

Skip loader cables and brakes must be inspected frequently to prevent injuries caused by falling skips. When work under an elevated skip is unavoidable, you must shore up the skip to prevent it from falling in the event that the brake fails or is accidentally released. The mixer operator must never lower the skip without first making sure that there is no one underneath.

Dust protection equipment must be issued to the crew engaged in handling cement, and the crew must wear the equipment when so engaged. Crewmembers should stand with their backs to the wind, whenever possible. This helps prevent cement and sand from being blown into their eyes and faces.

**HANDLING AND TRANSPORTING  
CONCRETE**

When ready-mixed concrete is carried by an ordinary type of carrier (such as a wheelbarrow or buggy), jolting of the carrier increases the natural tendency of the concrete to segregate. Carriers should therefore be equipped with pneumatic tires whenever possible, and the surface over which they travel should be as smooth as possible.

A long free fall also causes concrete to segregate. If the concrete must be discharged at a level more than 4 feet above the level of placement, it should be dumped into an "elephant trunk" similar to the one shown in figure 6-7.

Segregation also occurs when discharged concrete is allowed to glance off a surface, such as the side of a form or chute. Wheelbarrows, buggies, and conveyors should discharge so that the concrete falls clear.

Concrete should be transported by chute only for short distances. It tends to segregate and dry out when handled in this manner. For a mix of average workability  $y$ , the best slope for a chute is about 1 foot of rise to 2 or 3 feet of run. A steeper slope causes segregation, whereas a flatter slope causes the concrete to run slowly or not at all. The stiffer the mix, the steeper the slope required. All chutes and spouting used in concrete pours should be clean and well-supported by proper bracing and guys.

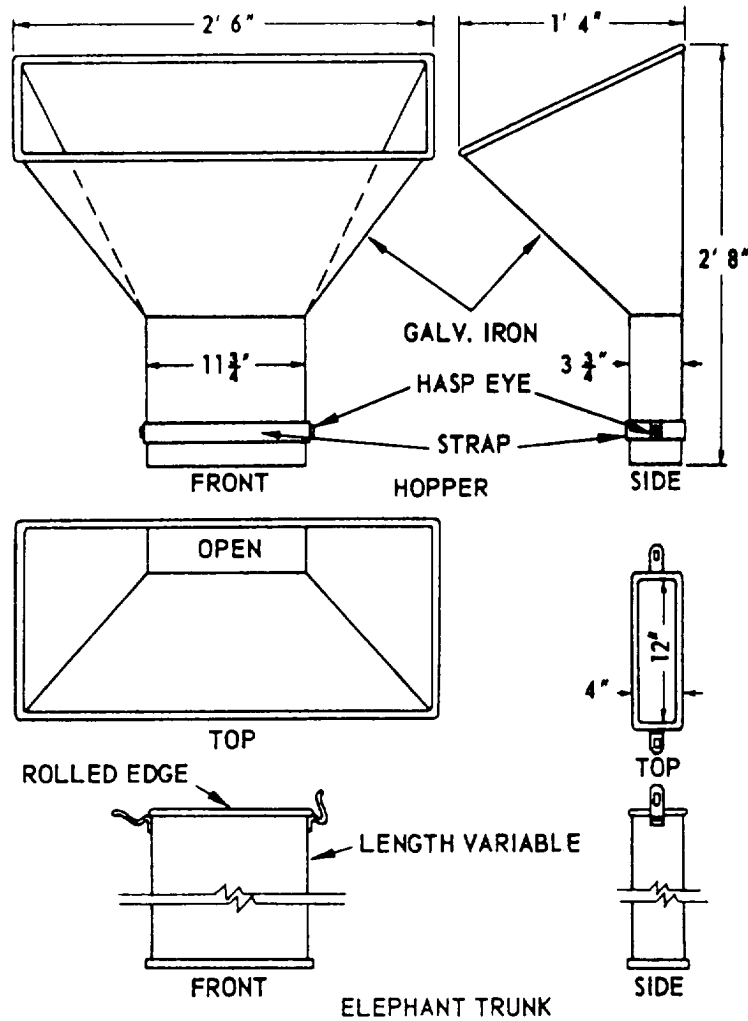
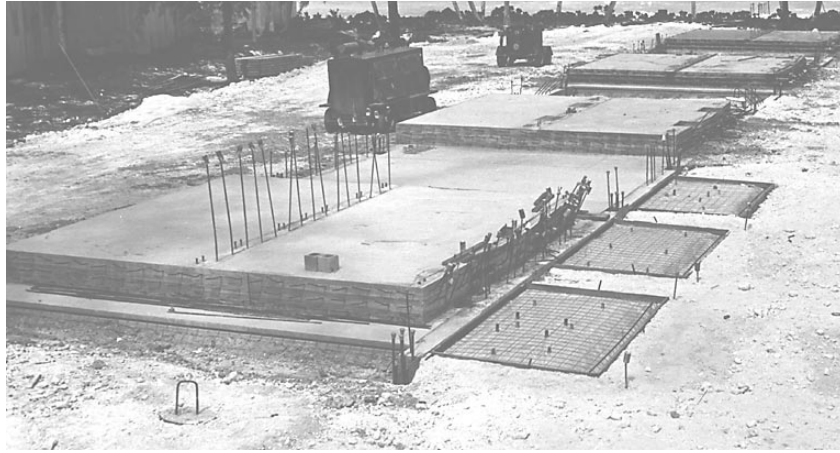

Figure 6-7.-Chute, or downpipe used to check free fall of concrete.



133.499

**Figure 6-8.-Precast wall panels in stacks of three each.**

When spouting and chutes run overhead, the area beneath must be cleared and barricaded during placing. This eliminates the concrete or possible collapse.

#### **READY-MIXED CONCRETE**

On some jobs, such as large danger of falling highway jobs, it is possible to use a batch plant that contains its own mixer. A plant of this type discharges ready-mixed concrete into transit mixers, which haul it to the construction site. The truck carries the mix in a revolving chamber much like the one on a mixer. Keeping the mix agitated in route prevents segregation of aggregate particles. A ready-mix plant is usually portable so that it can follow the job along. It must be certain, of course, that a truck will be able to deliver the mix at the site before it starts to set. Discharge of the concrete from the drum should be completed within 1 1/2 hours.

#### **TRANSIT-MIXED CONCRETE**

By transit-mixing, we refer to concrete that is mixed, either wet or dry, en route to a job site. A transit-mix truck carries a mixer and a water tank from which the driver can, at the proper time, introduce the required amount of water into the mix. The truck picks up the dry ingredients at the batch plant, together with a slip which tells how much water is to be introduced to the mix upon arrival at the site. The mixer drum is kept revolving in route and at the job site so that the dry ingredients do not segregate. Transit-mix trucks are part of the battalion's equipment inventory and are widely used

on all but the smallest concrete jobs assigned to a battalion.

#### **PRECAST AND TILT-UP CONCRETE**

*LEARNING OBJECTIVE: Upon completing this section, you should be able to determine projects suitable for and lifting methods necessary for precast and tilt-up construction.*

Concrete cast in the position it is to occupy in the finished structure is called cast-in-place concrete. Concrete cast and cured elsewhere is called precast concrete. Tilt-up concrete is a special type of precast concrete in which the units are tilted up and placed using cranes or other types of lifting devices.

Wall construction, for example, is frequently done with precast wall panels originally cast horizontally (sometimes one above the other) as slabs. This method has many advantages over the conventional method of casting in place in vertical wall forms. Since a slab form requires only edge forms and a single surface form, the amount of formwork and form materials required is greatly reduced. The labor involved in slab form concrete casting is much less than that involved in filling a high wall form. One side of a precast unit cast as a slab maybe finished by hand to any desired quality of finishing. The placement of reinforcing steel is much easier in slab forms, and it is easier to attain thorough filling and vibrating. Precasting of wall panels as slabs may be expedited by mass production methods not available when casting in place. Relatively light panels for concrete walls are precast as slabs (figure 6-8). The panels are set in



133.500

**Figure 6-9.-Precast panels being erected by use of crane and spreader bars.**

place by cranes, using spreader bars (figure 6-9).  
Figure 6-10 shows erected panels in final position

### **CASTING**

The casting surface is very important in making with precast concrete panels. In this

section, we will cover two common types: earth and concrete. Regardless of which method you use, however, a slab must be cast in a location that will permit easy removal and handling.

Castings can be made directly on the ground cement poured into forms. These "earth" surfaces are

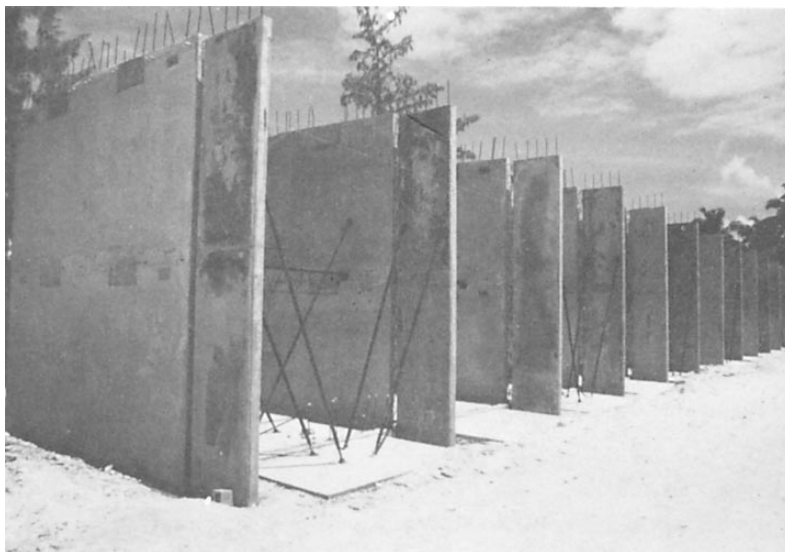

133.501

**Figure 6-10.-Precast panels in position.**

economical but only last for a couple of concrete pours. Concrete surfaces, since they can be reused repeatedly, are more practical.

When building casting surfaces, you should keep the following points in mind:

- The subbase should be level and properly compacted.
- The slab should be at least 6 inches thick and made of 3,000 psi or higher reinforced concrete. Large aggregate, 2 1/2 inches to 3 inches maximum, may be used in the casting slabs.
- If pipes or other utilities are to be extended up through the casting slab at a later date, they should be stopped below the surface and the openings temporarily closed. For wood, cork, or plastic plugs, fill almost to the surface with sand and top with a thin coat of mortar that is finished flush with the casting surface.
- It is important to remember that any imperfections in the surface of the casting slab will show up on the cast panels. When finishing the casting slab, you must ensure there is a flat, level, and smooth surface without humps, dips, cracks, or gouges. If possible, cure the casting surface keeping it covered with water (pending). However, if a curing compound or surface hardener is used, make sure it will not conflict with the later use of bond-breaking agents.

## FORMS

The material most commonly used for edge forms is 2-by lumber. The lumber must be occasionally replaced, but the steel or aluminum angles and channels may be reused many times. The tops of the forms must be in the same plane so that they may be used for screeds. They must also be well braced to remain in good alignment.

Edge forms should have holes in them for rebar or for expansion/contraction dowels to protrude. These holes should be 1/4 inch larger in diameter than the bars. At times, the forms are spliced at the line of these bars to make removal easier.

The forms, or rough bucks, for doors, windows, air-conditioning ducts, and so forth, are set before the steel is placed and should be on the same plane as the edge forms.

## BOND-BREAKING AGENTS

Bond-breaking agents are one of the most important items of precast concrete construction. The most important requirement is that they must break the bond between the casting surface and the cast panel. Bond-breaking agents must also be economical, fast drying, easily applied, easily removed, or leave a paintable surface on the cast panel, if desired. They are broken into two general types: sheet materials and liquids.

There are many commercially available bond-breaking agents available. You should obtain the type best suited for the project and follow the manufacturer's application instructions. If commercial bond-breaking agents are not available, several alternatives can be used.

- Paper and felt effectively prevent a bond with a casting surface, but usually stick to the cast panels and may cause asphalt stains on the concrete.
- When oiled, plywood, fiberboard, and metal effectively prevent a bond and can be used many times. The initial cost, however, is high and joint marks are left on the cast panels.
- Canvas gives a very pleasing texture and is used where cast panels are lifted at an early stage. It should be either dusted with cement or sprinkled with water just before placing the concrete.
- Oil gives good results when properly used, but is expensive. The casting slab must be dry when the oil is applied, and the oil must be allowed to absorb before the concrete is placed. Oil should not be used if the surface is to be painted, and crankcase oil should never be used.
- Waxes, such as spirit wax (paraffin) and ordinary floor wax, give good-to-excellent results. One mixture that may be used is 5 pounds of paraffin mixed with 1 1/2 gallons of light oil or kerosene. The oil must be heated to dissolve the paraffin.
- Liquid soap requires special care to ensure that an excess amount is not used or the surface of the cast panel will be sandy.

Materials should be applied after the side forms are in place and the casting slab is clean but **before**

any reinforcing steel is placed. To ensure proper adhesion of the concrete, keep all bond-breaking materials off the reinforcing steel.

## **REINFORCEMENTS AND INSERTS**

Reinforcing bars (rebar) should be assembled into mats and placed into the forms as a unit. This allows for rapid assembly on a jig and reduces walking on the casting surface, which has been treated with the bond-breaking agent.

Extra rebars must be used at openings. They should be placed parallel to and about 2 inches from the sides of openings or placed diagonally across the corners of openings.

The bars may be suspended by conventional methods, such as with high chairs or from members laid across the edge forms. However, high chairs should not be used if the bottom of the cast panel is to be a finished surface. Another method is to first place half the thickness of concrete, place the rebar mat, and then complete the pour. However, this method must be done quickly to avoid a cold joint between the top and bottom layers.

When welded wire fabric (WWF) is used, dowels or bars must still be used between the panels and columns. WWF is usually placed in sheets covering the entire area and then clipped along the edges of the openings after erection.

If utilities are going to be flush-mounted or hidden, pipe, conduit, boxes, sleeves, and so forth should be put into the forms at the same time as the reinforcing steel. If the utilities pass from one cast panel to another, the connections must be made after the panels are erected but before the columns are poured. If small openings are to go through the panel, a greased pipe sleeve is the easiest method of placing an opening in the form. For larger openings, such as air-conditioning ducts, forms should be made in the same reamer as doors or windows.

After rebar and utilities have been placed, all other inserts should be placed. These will include lifting and bracing inserts, anchor bolts, welding plates, and so forth. You need to make sure these items are firmly secured so they won't move during concrete placement or finishing.

## **POURING, FINISHING, AND CURING**

With few exceptions, pouring cast panels can be done in the same manner as other pours. Since the

panels are poured in a horizontal position, a stiffer mix can be used. A minimum of six sacks of cement per cubic yard with a maximum of 6 gallons of water per sack of cement should be used along with well-graded aggregate. As pointed out earlier, though, you will have to reduce the amount of water used per sack of cement to allow for the free water in the sand. Large aggregate, up to 1 1/2 inches in diameter, may be used effectively. The concrete should be worked into place by spading or vibration, and extra care must be taken to prevent honeycomb around outer edges of the panel.

Normal finishing methods should be used, but many finishing styles are available for horizontally cast panels. Some finishing methods include patterned, colored, exposed aggregate, broomed, floated, or steel-troweled. Regardless of the finish used, finishers must be cautioned to do the finishing of all panels in a uniform manner. Spots, defects, uneven brooming, or troweling, and so forth will be highly visible when the panels are erected.

Without marring the surface, curing should be started as soon as possible after finishing. Proper curing is important, so cast panels should be cured just like any other concrete to achieve proper strength. Curing compound, if used, prevents bonding with other concrete or paint.

## **LIFTING EQUIPMENT AND ATTACHMENTS**

Tilt-up panels can be set up in many different ways and with various kinds of power equipment. The choice depends upon the size of the job. Besides the equipment, a number of attachments are used.

### **Equipment**

The most popular power equipment is a crane. But other equipment used includes a winch and an A frame, used either on the ground or mounted on a truck. When a considerable number of panels are ready for tilting at one time, power equipment speeds up the job.

### **Attachments**

Many types of lifting attachments are used to lift tilt-up panels. Some of these attachments are locally made and are called hairpins; other types are available commercially. Hairpin types are made on the job site from rebar. These are made by making 180° bends in



the ends of two vertical reinforcing bars. The hairpins are then placed in the end of the panel before the concrete is poured. These lifting attachments must protrude from the top of the form for attaching the lifting chains or cables, but go deep enough in the panel form so they won't pull out.

Among the commercial types of lifting attachments, you will find many styles with greater lifting capacities that are more dependable than hairpins if properly installed. These are used with lifting plates. For proper placement of lifting inserts, refer to the plans or specs.

### Spreader Bars

Spreader bars (shown in figure 6-9) may be permanent or adjustable, but must be designed and made according to the heaviest load they will carry plus a safety factor. They are used to distribute the lifting stresses evenly, reduce the lateral force applied by slings, and reduce the tendency of panels to bow.

### POINT PICKUP METHODS

Once the concrete has reached the desired strength, the panels are ready to be lifted. The strength of the inserts is governed by the strength of the concrete.

#### CAUTION

An early lift may result in cracking the panel, pulling out the insert, or total concrete failure. The time taken to wait until the concrete has reached its full strength prevents problems and minimizes the risk of injury.

There are several different pickup methods. The following are just some of the basics. Before using these methods on a job, make sure that you check plans and specs to see if these are stated there. Figure 6-11 shows four different pickup methods: 2, 2-2, 4-4, and 2-2-2.

The 2-point pickup is the simplest method, particularly for smaller panels. The pickup cables or chains are fastened directly from the crane hook or spreader bar to two pickup points on or near the top of the precast panel.

The 2-2 point pickup is a better method and is more commonly used. Variations of the 2-2 are 4-4 and 2-2-2, or combinations of pickup points as designated in the job site specifications. These methods use a combination of spreader bars, sheaves, and equal-length cables. The main purpose is to

distribute the lifting stresses throughout the panel during erection. Remember, the cables must be long enough to allow ample clearance between the top of the panel and the sheaves or spreader bar.

### ERECTING, BRACING, AND JOINTING PANELS

Erecting is an important step in the construction phase of the project. Before you start the erecting phase and for increased safety, you should make sure that all your tools, equipment, and braces are in proper working order. All personnel must be well informed and the signalman and crane operator understand and agree on the signals to be used. During the erection of the panels, make sure that the signalman and line handler are not under the panel and that all unnecessary personnel and equipment are away from the lifting area. After the erection is done, make sure that all panels are properly braced and secured before unhooking the lifting cables.

Bracing is an especially important step. After all the work of casting and placing the panels, you want them to stay in place. The following are some steps to take before lifting the panels:

- Install the brace inserts into the panels during casting if possible.
- Install the brace inserts into the floor slab either during pouring or the day before erection.
- Install solid brace anchors before the day of erection.
- If brace anchors must be set during erection, use a method that is fast and accurate.

Although there are several types of bracing, pipe or tubular braces are the most common. They usually have a turnbuckle welded between sections for adjustment. Some braces are also made with telescoping sleeves for greater adaptability. Figure 6-10 shows tube-type braces used to hold up panels. Cable braces are normally used for temporary bracing and for very tall panels. Their flexibility and tendency to stretch, however, make them unsuitable for most projects. Wood bracing is seldom used except for low, small panels or for temporary bracing.

Jointing the panels is simple. Just tie all the panels together, covering the gap between them. You can weld, bolt, or pour concrete columns or beams. Steps used to tie the panels should be stated in the plans and specs.

TWO POINT PICKUP IS BEST SUITED TO WALL PANELS 10' TO 18' IN HEIGHT, AND UP TO 18' IN WIDTH FOR PANELS 5" TO 8" IN PANEL THICKNESS.

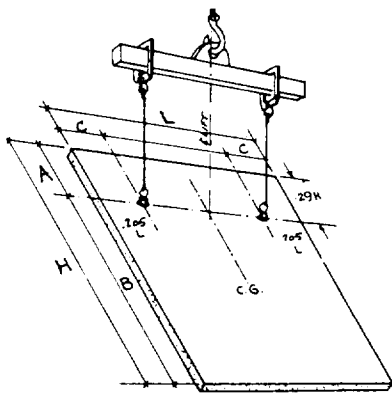

TRIAL POINTS				
H	A	B	L	C
8'	2'-3"	14'	2'-10"	
10'	2'-10"	15'	3'-1"	
12'	3'-6"	16'	3'-4"	
14'	4'-1"	17'	3'-6"	
16'	4'-7"	18'	3'-8"	
18'	5'-0"	19'	3'-10"	
20'	5'-2"	20'	4'-1"	

TRUCK DOOR 2-2 PICKUP				
TRIAL LOCATIONS				
H	A	B	L	C
18'	3'-0"	7'-10"	14'	2'-10"
20'	3'-3"	8'-6"	16'	3'-4"
22'	3'-7"	9'-6"	18'	3'-8"
24'	3'-10"	10'-6"	19'	3'-10"
26'	4'-0"	11'-6"	20'	4'-1"
27'	4'-3"	12'-0"	21'	4'-4"
28'	4'-6"	12'-6"	22'	4'-6"
29'	4'-9"	12'-10"	23'	4'-8"
30'	5'-0"	13'-1"	24'	4'-11"

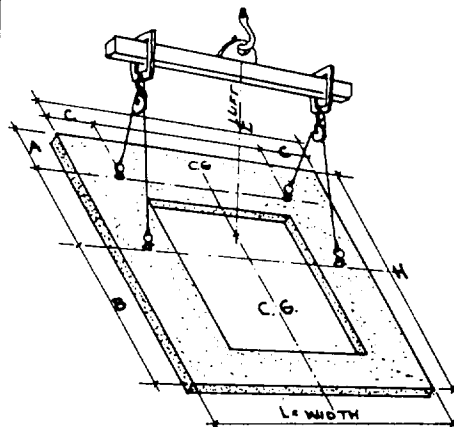

2 - 2 POINT PICKUP

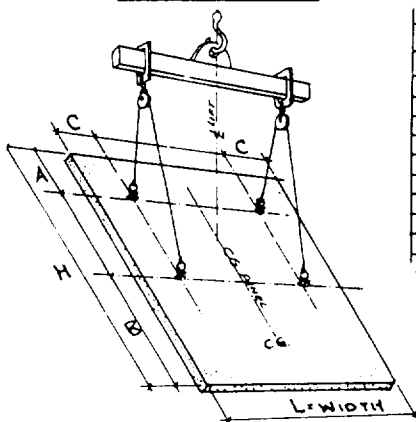

2-2 POINT PICKUP				
TRIAL LOCATIONS				
H	A	B	L	C
18'	3'-3"	7'-7"	12'	2'-6"
20'	3'-7"	8'-4"	14'	2'-10"
22'	3'-11"	9'-3"	15'	3'-1"
23'	4'-2"	9'-7"	16'	3'-4"
24'	4'-4"	10'-1"	17'	3'-6"
25'	4'-6"	10'-6"	18'	3'-8"
26'	4'-8"	11'-0"	19'	3'-10"
27'	4'-10"	11'-4"	20'	4'-1"
28'	5'-0"	11'-9"	21'	4'-4"
29'	5'-2"	12'-2"	22'	4'-6"
30'	5'-4"	12'-7"	23'	4'-8"

2-2-2 POINT PICKUP				
TRIAL LOCATIONS				
H	A	B	L	C
30'	4'-2 1/2"	9'-7"	16'	3'-4"
32'	4'-6"	10'-3"	18'	3'-8"
34'	4'-10"	10'-10"	19'	3'-10"
36'	5'-0"	11'-6"	20'	4'-1"
38'	5'-4"	12'-2"	22'	4'-6"
40'	5'-7"	12'-9"	24'	4'-11"
42'	5'-9"	13'-4"	25'	5'-1"

4 - 4 POINT PICKUP

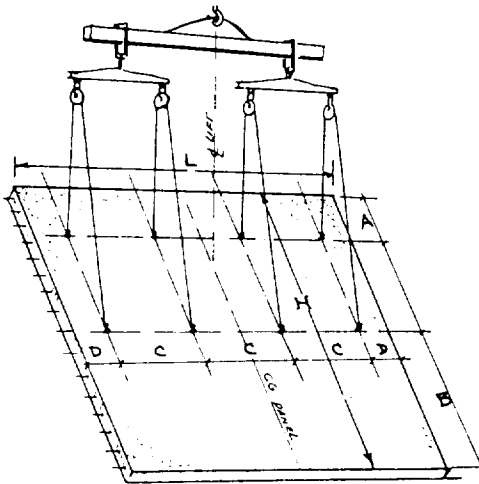

4-4 POINT PICKUP					
TRIAL LOCATIONS					
H	A	B	L	C	D
18'	3'-3"	7'-7"	18'	4'-8"	2'-0"
20'	3'-7"	8'-4"	20'	5'-3"	2'-1 1/2"
22'	3'-11"	9'-3"	22'	5'-10"	2'-3 1/4"
23'	4'-2"	9'-7"	24'	6'-4"	2'-6"
24'	4'-4"	10'-1"	26'	6'-10"	2'-9"
25'	4'-6"	10'-6"	28'	7'-4"	3'-0"
26'	4'-8"	11'-0"	30'	8'-0"	3'-0"
27'	4'-10"	11'-4"	32'	8'-6"	3'-4"
28'	5'-0"	11'-9"	34'	9'-0"	3'-6"
29'	5'-2"	12'-2"	36'	9'-6"	3'-8"
30'	5'-4"	12'-7"	38'	10'-2"	3'-10"
31'	5'-7"	13'-0"	39'	10'-8"	4'-0"
32'	5'-9"	13'-4"	40'	10'-8"	4'-3"

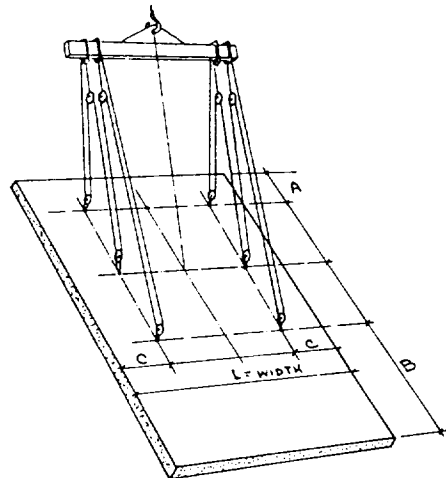

Figure 6-11.-Different types of pickup points.

## RECOMMENDED READING LIST

### NOTE

Although the following references were current when this TRAMAN was published, their continued currency cannot be assured. You therefore need to ensure that you are studying the latest revision.

*Concrete and Masonry*, FM 5-742, Headquarters, Department of the Army, Washington, D.C., 1985.

*Concrete Formwork*, Keel, Leonard, American Technical Publishers, Inc., Homewood, Ill., 1988.

*Design and Control of Concrete Mixtures*, Portland Cement Association, Skokie, Ill., 1988.



## CHAPTER 7

# WORKING WITH CONCRETE

Concrete is the principal construction material used in most construction projects. The quality control of concrete and its placement are essential to ensure its final strength and appearance. Proper placement methods must be used to prevent segregation of the concrete.

This chapter provides information and guidance for you, the Builder, in the forming, placement, finishing, and curing of concrete. Information is also provided on the placement of reinforcing steel, and the types of ties required to ensure nonmovement of reinforcing once positioned. You will also be provided necessary information on concrete construction joints and the concrete saw. At the end of the chapter, you will find helpful references. You are encouraged to study these references, as required, for additional information on the topics discussed.

### FORMWORK

*LEARNING OBJECTIVE: Upon completing this section, you should be able to describe the types of concrete forms and their construction.*

Most structural concrete is made by placing or “casting” plastic concrete into spaces enclosed by previously constructed forms. The plastic concrete hardens into the shape outlined by the forms. The size and shape of the formwork are always based on the project plans and specifications.

Forms for all concrete structures must be tight, rigid, and strong. If the forms are not tight, there will be excessive leakage at the time the concrete is placed. This leakage can result in unsightly surface ridges, honeycombing, and sand streaks after the concrete has set. The forms must be able to safely withstand the pressure of the concrete at the time of placement. No shortcuts should be taken. Proper form construction material and adequate bracing in place prevent the forms from collapsing or shifting during the placement of the concrete.

Forms or form parts are often omitted when a firm earth surface exists that is capable of supporting or molding the concrete. In most footings, the bottom of

the footing is cast directly against the earth and only the sides are molded in forms. Many footings are cast with both the bottom and the sides against the natural earth. In these cases, however, the specifications usually call for larger footings. A foundation wall is often cast between a form on the inner side and the natural earth surface on the outer side.

### FORM MATERIALS

Forms are generally constructed from either earth, metal, wood, fiber, or fabric.

#### Earth

Earthen forms are used in subsurface construction where the soil is stable enough to retain the desired shape of the concrete. The advantages of earthen forms are that less excavation is required and there is better settling resistance. The obvious disadvantage is a rough surface finish, so the use of earthen forms is generally restricted to footings and foundations. Precautions must be taken to avoid collapse of the sides of trenches.

#### Metal

Metal forms are used where high strength is required or where the construction is duplicated at more than one location. They are initially more expensive than wood forms, but may be more economical if they can be reused repeatedly. Originally, all prefabricated metal forms were made of steel. These forms were heavy and hard to handle. Currently, aluminum forms, which are lightweight and easier to handle, are replacing steel.

Prefabricated metal forms are easy to erect and strip. The frame on each panel is designed so that the panels can be easily and quickly fastened and unfastened. Metal forms provide a smooth surface finish so that little concrete finishing is required after the forms are stripped. They are easily cleaned, and maintenance is minimal.

Metal-wood forms are just like metal forms except for the face. It is made with a sheet of B-grade exterior plywood with waterproof glue.

## Wood

Wooden forms are by far the most common type used in building construction. They have the advantage of economy, ease in handling, ease of production, and adaptability to many desired shapes. Added economy may result from reusing form lumber later for roofing, bracing, or similar purposes. Lumber should be straight, structurally sound, strong, and only partially seasoned. Kiln-dried timber has a tendency to swell when soaked with water from the concrete. If the boards are tight-jointed, the swelling will cause bulging and distortion. When green lumber is used, an allowance should be made for shrinkage, or the forms should be kept wet until the concrete is in place. Soft woods, such as pine, fir, and spruce, make the best and most economical form lumber since they are light, easy to work with, and available in almost every region.

Lumber that comes in contact with concrete should be surfaced at least on one side and both edges. The surfaced side is turned toward the concrete. The edges of the lumber may be square, shiplap, or tongue and groove. The latter makes a more watertight joint and tends to prevent warping.

Plywood can be used economically for wall and floor forms if it is made with waterproof glue and is identified for use in concrete forms. Plywood is more warp resistant and can be reused more often than lumber. Plywood is made in 1/4-, 3/8-, 1/2-, 9/16-, 5/8- and 3/4-inch thicknesses and in widths up to 48 inches. Although longer lengths are manufactured, 8-foot lengths are the most common. The 5/8- and 3/4-inch thicknesses are most economical; thinner sections require additional solid backing to prevent bulging. However, the 1/4-inch thickness is useful for forming curved surfaces.

## Fiber

Fiber forms are prefabricated from impregnated waterproofed cardboard and other fiber materials. Successive layers of fiber are first glued together and then molded in the desired shape. Fiber forms are ideal for round concrete columns and other applications where preformed shapes are feasible

since they require no form fabrication at the job site. This saves considerable time and money.

## Fabric

Fabric forming is made of two layers of nylon fabric. These layers are woven together, forming an envelope. Structural mortar is injected into these envelopes, forming nylon-encased concrete "pillows." These are used to protect the shorelines of waterways, lakes and reservoirs, and as drainage channel linings.

Fabric forming offers exceptional advantages in the structural restoration of bearing piles under waterfront structures. A fabric sleeve with a zipper closure is suspended around the pile to be repaired, and mortar is pumped into the sleeve. This forms a strong concrete jacket.

## FORM DESIGN

Forms for concrete construction must support the plastic concrete until it has hardened. Stiffness is an important feature in forms. Failure to provide form stiffness may cause unfortunate results. Forms must be designed for all the weight to which they are likely to be subjected. This includes the dead load of the forms, the plastic concrete in the forms, the weight of the workmen, the weight of equipment and materials, and the impact due to vibration. These factors vary with each project, but none should be ignored. The ease of erection and removal is also an important factor in the economical design of forms. Platform and ramp structures independent of formwork are sometimes preferred to avoid displacement of forms due to loading and impact shock from workmen and equipment.

When concrete is placed in forms, it is in a plastic state and exerts hydrostatic pressure on the forms. The basis of form design, therefore, is the maximum pressure developed by concrete during placing. The maximum pressure developed depends on the placing rate and the temperature. The rate at which concrete is placed affects the pressure because it determines how much hydrostatic head builds up in the form. The hydrostatic head continues to increase until the concrete takes its initial set, usually in about 90 minutes. At low temperatures, however, the initial set takes place much more slowly. This makes it necessary to consider the temperature at the time of

placing. By knowing these two factors and the type of form material to be used, you can calculate a tentative design.

## FORM CONSTRUCTION

Strictly speaking, it is only those parts of the form work that directly mold the concrete that are correctly referred to as the “forms.” The rest of the formwork consists of various bracing and tying members. In the following discussion on forms, illustrations are provided to help you understand the names of all the formwork members. You should study these illustrations carefully so that you will understand the material in the next section.

### Foundation Forms

The portion of a structure that extends above the ground level is called the superstructure. The portion below the ground level is called the substructure. The parts of the substructure that distribute building loads to the ground are called foundations. Footings are installed at the base of foundations to spread the loads over a larger ground area. This prevents the structure from sinking into the ground. It's important to remember that the footings of any foundation system should always be placed below the frost line. Forms for large footings, such as bearing wall footings, column footings, and pier footings, are called foundation forms. Footings, or foundations, are relatively low in height since their primary function is to distribute building loads. Because the concrete in a footing is shallow, pressure on the form is relatively low. Therefore, a form design based on high strength and rigidity considerations is generally not necessary.

**SIMPLE FOUNDATION.**— Whenever possible, excavate the earth and use it as a mold for concrete footings. You should thoroughly moisten the earth before placing the concrete. If this is not possible, you must construct a form. Because most footings are rectangular or square, you can build and erect the four sides of the form in panels.

Make the first pair of opposing panels (figure 7-1 (a)) to exact footing width. Then, nail vertical cleats to the exterior sides of the sheathing. Use at least

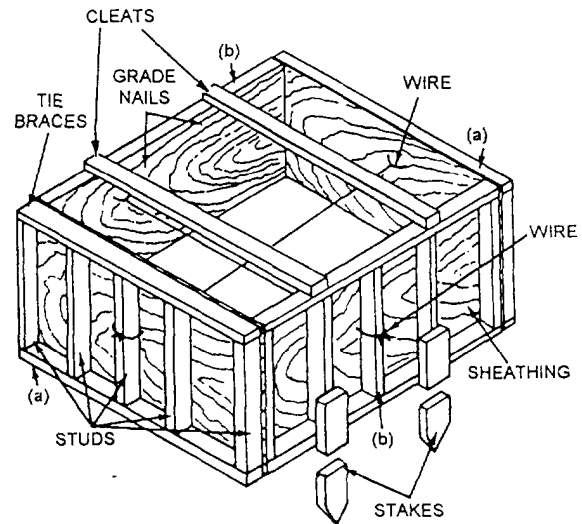

Figure 7-1.-Typical foundation form for a large footing.

1-by-2-inch lumber for the cleats, and space them 2 1/2 inches from each end of the exterior sides of the panels (a), and on 2-foot centers between the ends. Next, nail two cleats to the ends of the interior sides of the second pair of panels (figure 7-1 (b)). The space between these panels should equal the footing length plus twice the sheathing thickness. Then, nail cleats on the exterior sides of the panels (b) spaced on 2-foot centers.

Erect the panels into either a rectangle or square, and hold them in place with form nails. Make sure that all reinforcing bars are in place. Now, drill small holes on each side of the center cleat on each panel. These holes should be less than 1/2 inch in diameter to prevent paste leakage. Pass No. 8 or No. 9 black annealed iron wire through these holes and wrap it around the center cleats of the opposing panels to hold them together (see figure 7-1). Mark the top of the footing on the interior side of the panels with grade nails.

For forms 4 feet square or larger, drive stakes against the sheathing, as shown in figure 7-1. Both the stakes and the 1 by 6 tie braces nailed across the top of the form keep it from spreading apart. If a footing is less than 1-foot deep and 2-feet square, you can construct the form from 1-inch sheathing without cleats. Simply make the side panels higher than the footing depth, and mark the top of the footing on the interior sides of the panels with grade nails. Cut and

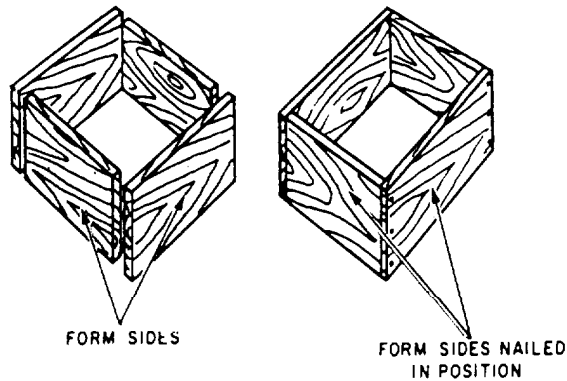

Figure 7-2.-Typical small footing form.

nail the lumber for the sides of the form, as shown in figure 7-2.

**FOUNDATION AND PIER FORMS COMBINED.**— You can often place a footing and a small pier at the same time. A pier is a vertical member that supports the concentrated loads of an arch or bridge superstructure. It can be either rectangular or round. You build a pier form as shown in figure 7-3. The footing form should look like the one in figure 7-1. You must provide support for the pier form while not interfering with concrete placement in the footing form. You can do this by first nailing 2-by-4s or 4-by-4s across the footing form, as shown in figure 7-3. These serve as both supports and tie braces. Then, nail the pier form to these support pieces.

**BEARING WALL FOOTINGS.**— Figure 7-4 shows a typical footing formwork for a bearing wall, and figure 7-5 shows bracing methods for a bearing

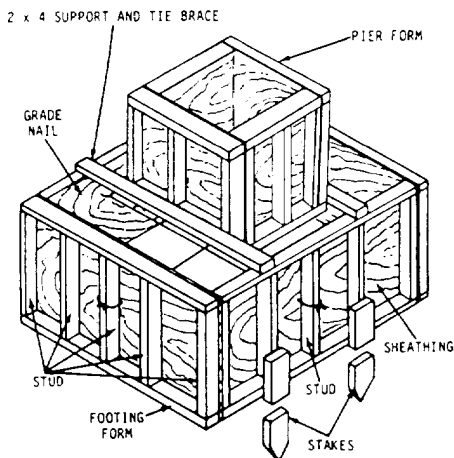

Figure 7-3.-Footing and pier form.

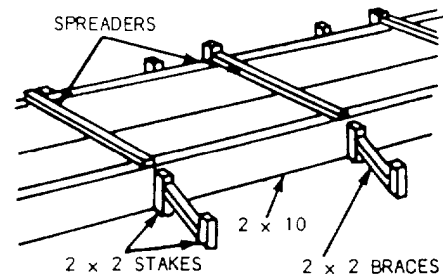

Figure 7-4.-Typical footing form.

wall footing. A bearing wall, also called a load-bearing wall, is an exterior wall that serves as an enclosure and also transmits structural loads to the foundation. The form sides are 2-inch lumber whose width equals the footing depth. Stakes hold the sides in place while spreaders maintain the connect distance between them. The short braces at each stake hold the form in line.

A keyway is made in the wet concrete by placing a 2-by-2-inch board along the center of the wall footing form. After the concrete is thy, the board is removed. This leaves an indentation, or key, in the concrete. When you pour the foundation wall, the key provides a tie between the footing and wall. Although not discussed in this training manual, there are several commercial keyway systems available for construction projects.

### Columns

Square column forms are made of wood. Round column forms are made of steel, or cardboard

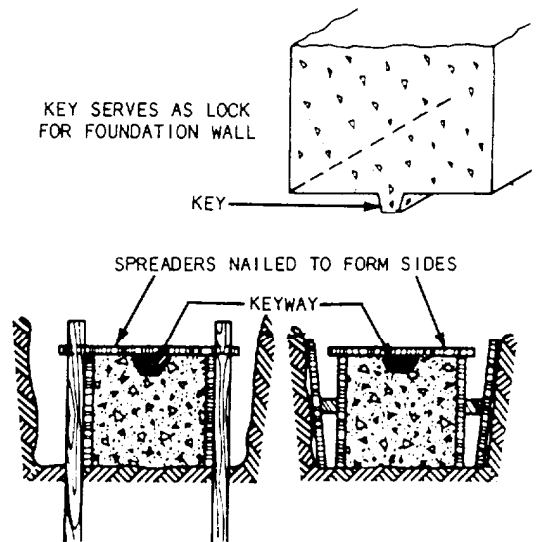

Figure 7-5.-Methods of bracing bearing wall footing forms and placing a keyway.



impregnated with waterproofing compound. Figure 7-6 shows an assembled column and footing form. After constructing the footing forms, build the column form sides, and then nail the yokes to them.

Figure 7-7 shows a column form with two styles of yokes. View A shows a commercial type, and view B shows yokes made of all-thread bolts and 2-by material. Since the rate of placing concrete in a column form is very high and the bursting pressure exerted on the form by the concrete increases directly with the rate of placing, a column form must be securely braced, as shown by the yokes in the figure. Because the bursting pressure is greater at the bottom of the form than it is at the top, yokes are placed closer together at the bottom.

The column form should have a clean-out hole cut in the bottom from which to remove construction debris. Be sure to nail the pieces that you cut to make the clean-out hole to the form. This way, you can replace them exactly before placing concrete in the column. The intention of the clean-out is to ensure that the surface which bonds with the new concrete is clear of all debris.

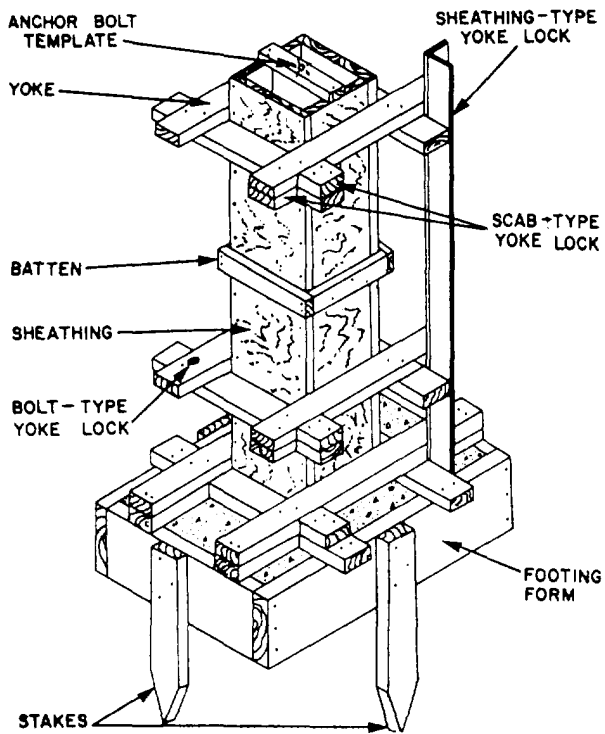

Figure 7-6.-Form for a concrete column.

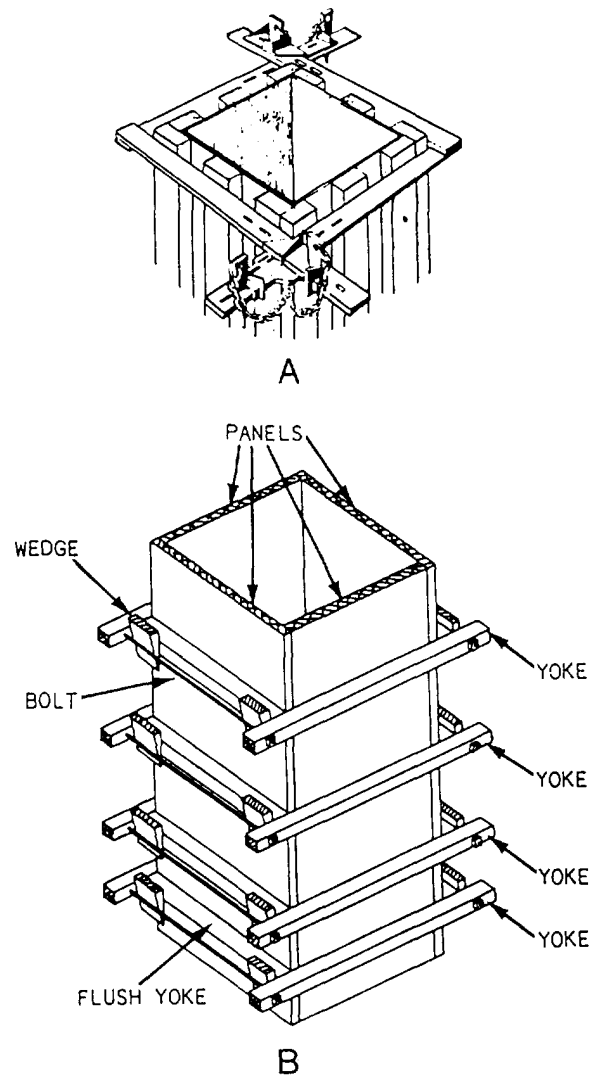

Figure 7-7.-Column form with scissor clamp (View A), and yolk and wedge (View B).

## Walls

Wall forms (figure 7-8) may be built in place or prefabricated, depending on shape and desirability of

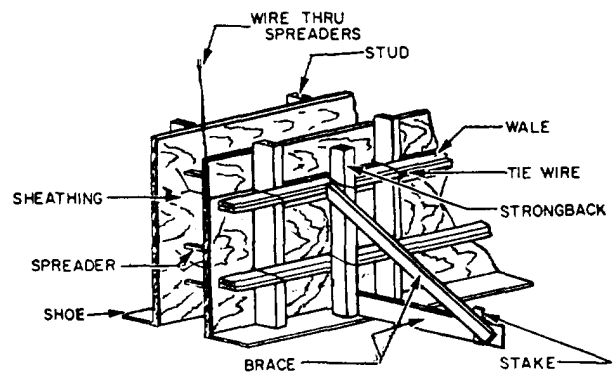

Figure 7-8.-Form for a concrete wall.

form reuse. Some of the elements that make up wooden forms are sheathing, studs, wales, braces, shoe plates, spreaders, and tie wires.

**CONSTRUCTION.**— Sheathing forms the surfaces of the concrete. It should be as smooth as possible, especially if the finished surfaces are to be exposed. Since the concrete is in a plastic state when placed in the form, the sheathing should be watertight. Tongue-and-groove sheathing gives a smooth, watertight surface. Plywood or hardboard can also be used and is the most widely accepted construction method.

The weight of the plastic concrete causes sheathing to bulge if it is not reinforced. As a result, studs are run vertically to add rigidity to the wall form. Studs are generally made from 2-by-4 or 3-by-6 material.

Studs also require reinforcing when they extend over 4 or 5 feet. This reinforcing is supplied by double wales. Double wales also serve to tie prefabricated panels together and keep them in a straight line. They run horizontally and are lapped at the corners of the forms to add rigidity. Wales are usually made of the same material as the studs.

The shoe plate is nailed into the foundation or footing. It is carefully placed to maintain the correct wall dimension and alignment. The studs are tied into the shoe and spaced according to the correct design.

Small pieces of wood are cut the same length as the thickness of the wall and are placed between the forms to maintain proper distance between forms. These pieces are known as spreaders. The spreaders are not nailed but are held in place by friction and must be removed before the concrete covers them. A wire should be securely attached to each spreader so that the spreaders can be pulled out after the concrete has exerted enough pressure on the walls to allow them to be easily removed.

lie wire is designed to hold the forms securely against the lateral pressure of unhardened concrete. A double strand of tie wire is always used.

**BRACING.**— Many types of braces can be used to add stability and bracing to the forms. The most common type is a diagonal member and horizontal member nailed to a stake and to a stud or wale, as shown in figure 7-8. The diagonal member should make a 30° angle with the horizontal member.

Additional bracing may be added to the form by placing vertical members (strongbacks) behind the wiles or by placing vertical members in the corner formed by intersecting wales. Braces are not part of the form design and are not considered as providing any additional strength.

**REINFORCEMENT.**— Wall forms are usually reinforced against displacement by the use of ties. Two types of simple wire ties, used with wood spreaders, are shown in figure 7-9. The wire is passed around the studs, the wales, and through small holes bored in the sheathing. Each spreader is placed as close as possible to the studs, and the tie is set taut by the wedge, as shown in view A of figure 7-9, or by twisting with a small toggle, as shown in view B. As the concrete reaches the level of each spreader, the spreader is knocked out and removed. Figure 7-10 shows you an easy way to remove the spreaders by drilling holes and placing a wire through them. The parts of the wire that are inside the forms remain in the concrete; the outside surplus is cut off after the forms are removed.

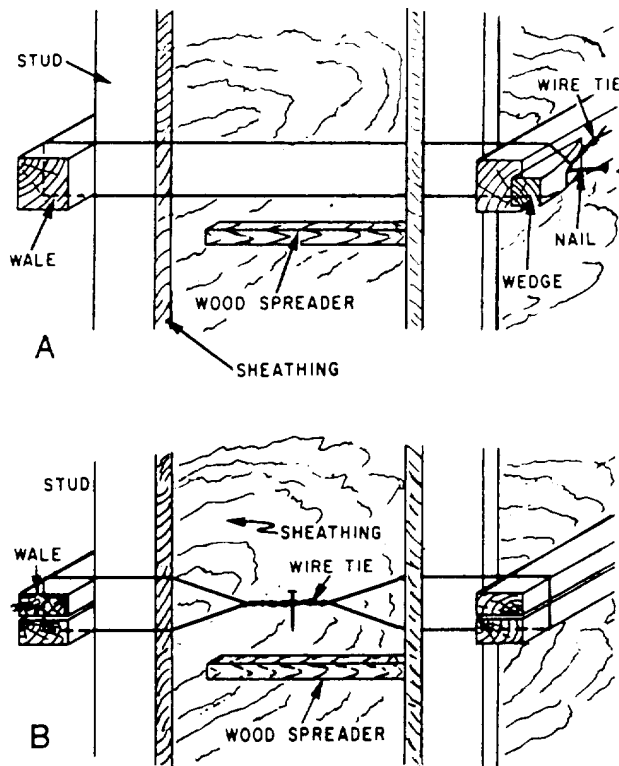

Figure 7-9.-Wire ties for wall forms.

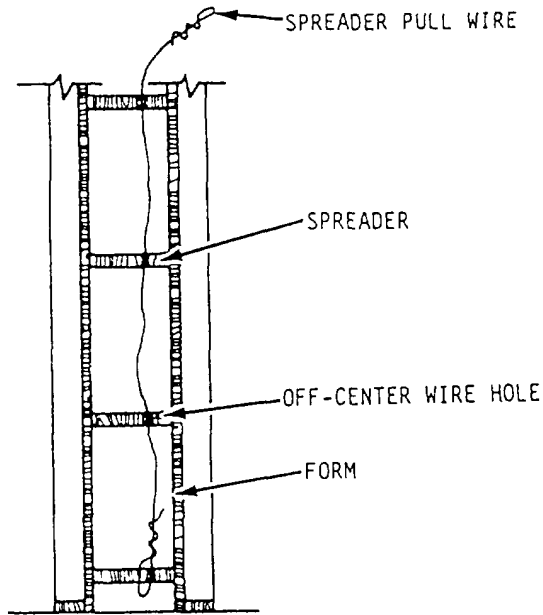

Figure 7-10.-Removing wood spreaders.

Wire ties and wooden spreaders have been largely replaced by various manufactured devices in which the function of the tie and the function of the spreader are combined. Figure 7-11 shows one of these. It is called a snap tie. These ties are made in various sizes to fit various wall thicknesses. The tie holders can be removed from the tie rod. The rod goes through small holes bored in the sheathing, and also through the

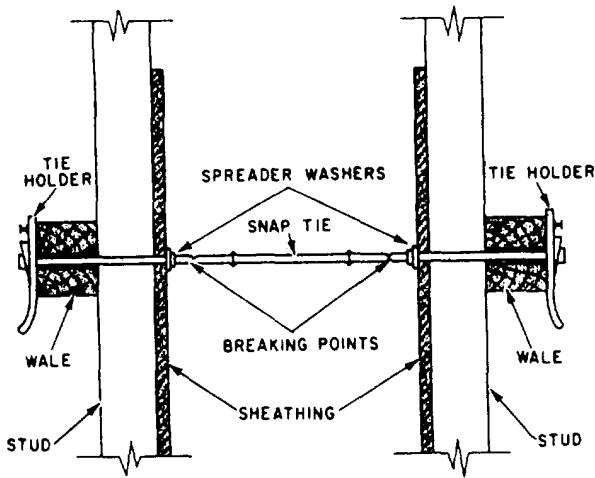

Figure 7-11.-Snap tie.

wales, which are usually doubled for that purpose. Tapping the tie holders down on the ends of the rod brings the sheathing to bear solidly against the spreader washers. You can prevent the tie holder from coming loose by driving a duplex nail in the provided hole. After the concrete has hardened, the tie holders can be detached to strip the forms. After the forms are stripped, a special wrench is used to break off the outer sections of rods. The rods break off at the breaking points, located about 1-inch inside the surface of the concrete. Small surface holes remain, which can be plugged with grout if necessary.

Another type of wall-form tie is the tie rod (figure 7-12). This rod consists of an inner section that is threaded on both ends and two threaded outer sections. The inner section with the cone nuts set to the thickness of the wall is placed between the forms, and the outer sections are passed through the wales and sheathing and threaded into the cone nuts. The clamps are then threaded on the outer sections to bring the forms to bear against the cone nuts. After the concrete hardens, the clamps are loosened, and the outer sections of rod are removed by threading them out of the cone nuts. After the forms are stripped, the cone nuts are removed from the concrete by threading them off the inner sections of the rod with a special wrench. The cone-shaped surface holes that remain can be plugged with grout. The inner sections of the rod remain in the concrete. The outer sections and the cone nuts may be reused indefinitely.

Wall forms are usually constructed as separate panels. Make the panels by first nailing sheathing to the studs. Next, connect the panels, as shown in

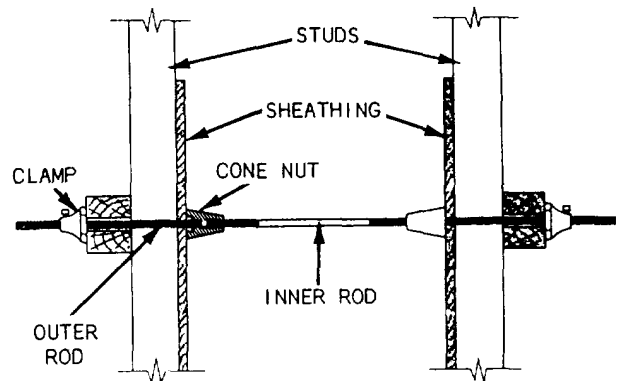

Figure 7-12.-Tie rod.

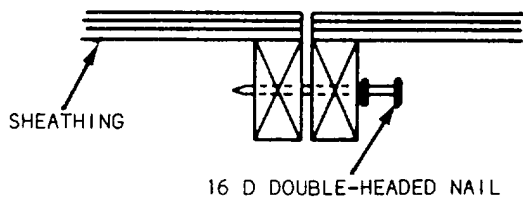

Figure 7-13.-Joining wall form panels together in line.

figure 7-13. Figure 7-14 shows the form details at the wall corner. When placing concrete panel walls and columns at the same time, construct the wall form, as shown in figure 7-15. Make the wall form shorter than the distance between the column forms to allow for a wood strip that acts as a wedge. When stripping the forms, remove the wedge first to aid in form removal.

### Stair Forms

Concrete stairway forms require accurate layout to ensure accurate finish dimensions for the stairway. Stairways should always be reinforced with rebars (reinforcing bars) that tie into the floor and landing. They are formed monolithically or formed after the concrete for the floor slab has set. Stairways formed after the slab has set must be anchored to a wall or beam by tying the stairway rebars to rebars projecting from the walls or beams, or by providing a keyway in the beam or wall. You can use various stair forms, including prefabricated forms. For moderate-width stairs joining typical floors, a design based on strength considerations is generally not necessary. Figure 7-16 shows one way to construct forms for stair widths up to and including 3 feet. Make the sloping wood platform that serves as the form for the

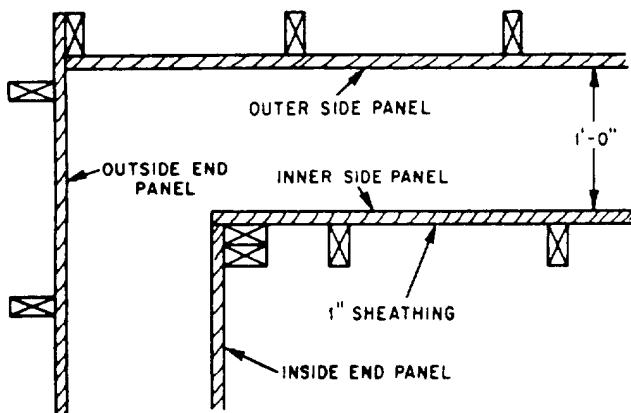
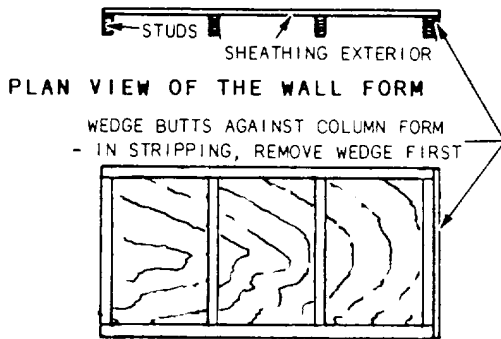

Figure 7-14.-Joining wall form panels at a corner.



ELEVATION OF WALL FORM

Figure 7-15.-Form for panel wall and columns.

underside of the steps from 3/4-inch plywood. The platform should extend about 12 inches beyond each side of the stairs to support the stringer bracing blocks. Shore up the back of the platform with 4-by-4 supports, as shown in figure 7-16. The post supports should rest on wedges for easy adjustment and removal. Cut 2-by-12 planks for the side stringers to fit the treads and risers. Bevel the bottom of the 2-by-12 risers for easy form removal and finishing.

### Beams and Girders

The type of construction used for beam and girder forms depends upon whether the forms are to be removed in one piece or whether the sides are to be

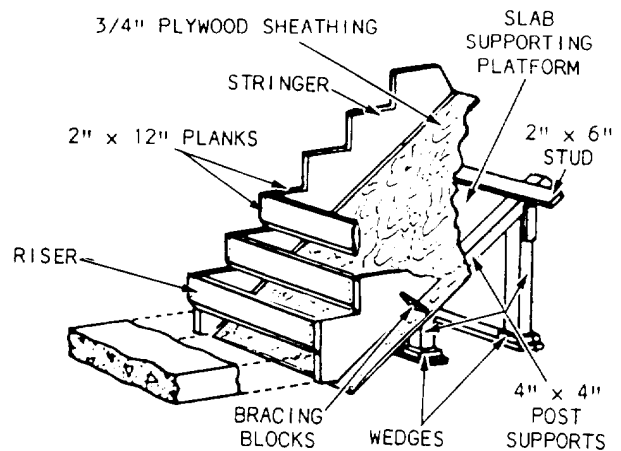

Figure 7-16.-Stairway form.

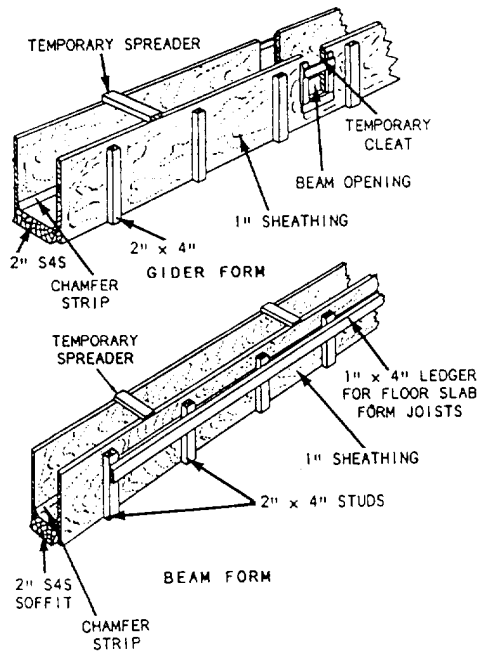

Figure 7-17.-Typical beam and girder form.

stripped and the bottom left in place until the concrete has hardened enough to permit removal of the shoring. The latter type of form is preferred, and details for this type are shown in figure 7-17. Although beam and girder forms are subjected to very little bursting pressure, they must be shored up at frequent intervals to prevent sagging under the weight of fresh concrete.

The bottom of the form should be the same width as the beam and should be in one piece for the full width. The sides of the form should be 1-inch-thick tongue-and-groove sheathing and should lap over the bottom as shown in figure 7-17. The sheathing is nailed to 2-by-4-inch studs placed on 3-foot centers. A 1-by-4-inch piece is nailed along the studs. These pieces support the joist for the floor panel, as shown in figure 7-18, detail E. The beam sides of the form are not nailed to the bottom. They are held in position by continuous strips, as shown in detail E. The

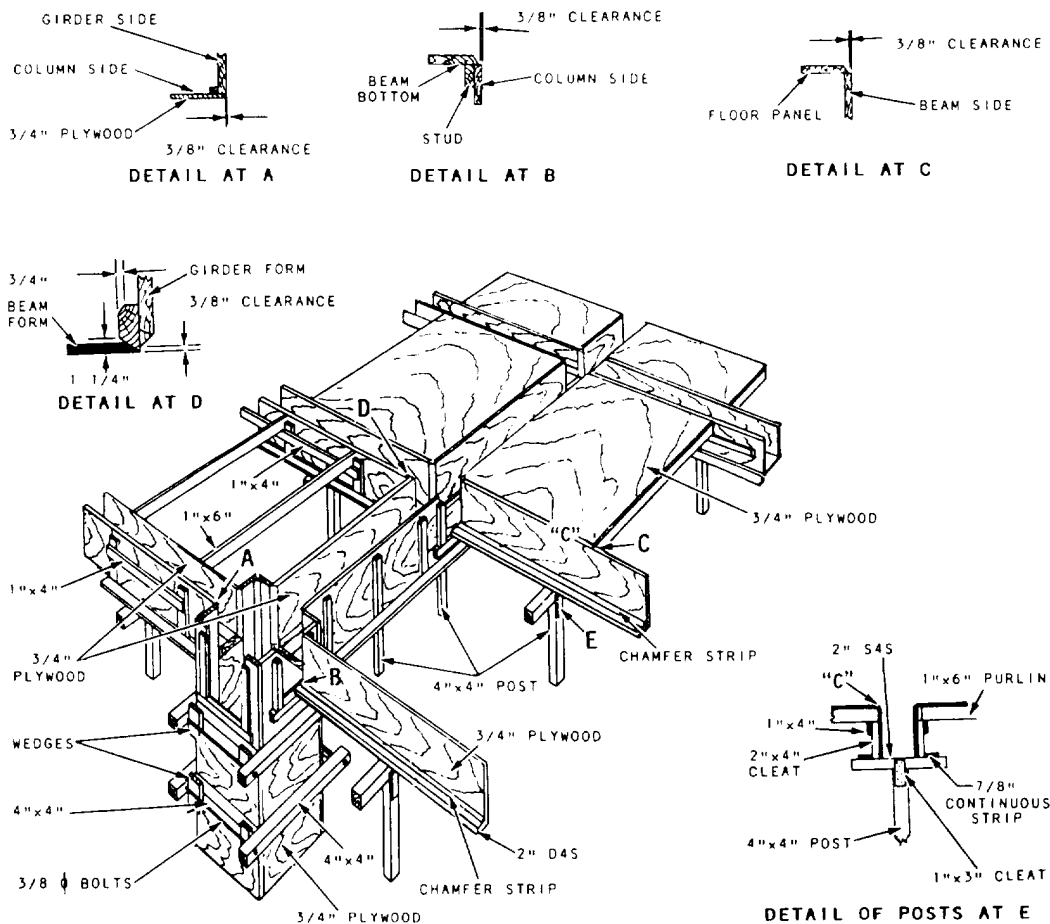

Figure 7-18.-Assembly of beam and floor forms.

crosspieces nailed on top serve as spreaders. After erection, the slab panel joists hold the beam sides in position. Girder forms (figure 7-17) are the same as beam forms except that the sides are notched to receive the beam forms. Temporary cleats should be nailed across the beam opening when the girder form is being handled.

The entire method of assembling beam and girder forms is illustrated in figure 7-18. The connection of the beam and girder is illustrated in detail D. The beam bottom butts up tightly against the side of the girder form and rests on a 2-by-4-inch cleat nailed to the girder side. Detail C shows the joint between the beam and slab panel, and details A and B show the joint between the girder and column. The clearances given in these details are needed for stripping and also to allow for movement that occurs due to the weight of the fresh concrete. The 4-by-4 posts (detail E) used for shoring the beams and girders should be spaced to provide support for the concrete and forms. They should be wedged at the bottom to obtain proper elevation.

Figure 7-19 shows you how the same type of forming can be done by using quick beams, scaffolding, and I-beams—if they are available. This type of system can be set up and taken down in minimum time.

### Oiling and Wetting Forms

You should never use oils or other form coatings that may soften or stain the concrete surface, prevent the wet surfaces from water curing, or hinder the proper functioning of sealing compounds used for curing. If you cannot obtain standard form oil or other form coating, you can wet the forms to prevent sticking in an emergency.

**OIL FOR WOOD FORMS.**— Before placing concrete in wood forms, treat the forms with a suitable form oil or other coating material to prevent the concrete from sticking to them. The oil should penetrate the wood and prevent water absorption. Almost any light-bodied petroleum oil meets these specifications. On plywood, shellac works better than oil in preventing moisture from raising the grain and detracting from the finished concrete surface. Several commercial lacquers and similar products are also available for this purpose. If you plan to reuse wood forms repeatedly, a coat of paint or sealing compound will help preserve the wood. Sometimes lumber contains enough tannin or other organic substance to

soften the concrete surface. To prevent this, treat the form surfaces with whitewash or limewater before applying the form oil or other coating.

**OIL FOR STEEL FORMS.**— Oil wall and steel column forms before erecting them. You can oil all other steel forms when convenient, but they should be oiled before the reinforcing steel is placed. Use specially compounded petroleum oils, not oils intended for wood forms. Synthetic castor oil and some marine engine oils are examples of compound oils that give good results on steel forms.

**APPLYING OIL.**— The successful use of form oil depends on how you apply it and the condition of the forms. They should be clean and have smooth surfaces. Because of this, you should not clean forms with wire brushes, which can mar their surfaces and cause concrete to stick. Apply the oil or coating with a brush, spray, or swab. Cover the form surfaces evenly, but do not allow the oil or coating to contact construction joint surfaces or any reinforcing steel in the formwork. Remove all excess oil.

**OTHER COATING MATERIALS.**— Fuel oil, asphalt paint, varnish, and boiled linseed oil are also suitable coatings for forms. Plain fuel oil is too thin to use during warm weather, but mixing one part petroleum grease to three parts of fuel oil provides adequate thickness.

### Form Failure

Even when all form work is adequately designed, many form failures occur because of human error, improper supervision, or using damaged materials. The following list highlights some, but not all, of the most common construction deficiencies that supervisory personnel should consider when working with concrete:

- Inadequately tightened or secured form ties;
- Inadequate diagonal bracing of shores;
- Use of old, damaged, or weathered form materials;
- Use of undersized form material;
- Shoring not plumb;
- Failure to allow for lateral pressures on form work; and

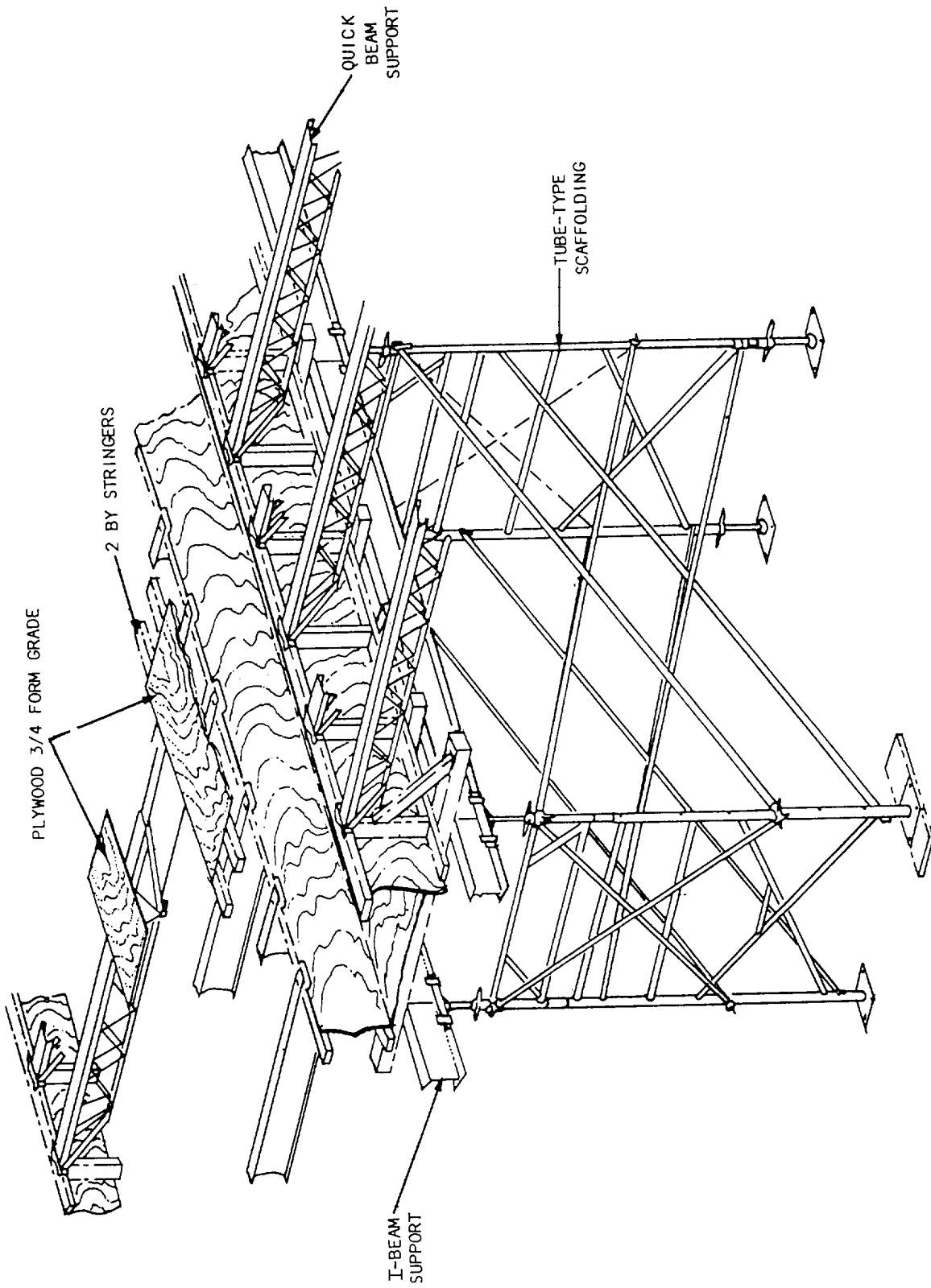

Figure 7-19.—Beam and floor forms.

- Failure to inspect form work during and after concrete placement to detect abnormal deflections or other signs of imminent failure.

There are many reasons why forms fail. It is the responsibility of the Builder to ensure that the forms are correctly constructed according to design, and that proper techniques are followed.

## REINFORCED CONCRETE

*LEARNING OBJECTIVE: Upon completing this section, you should be able to determine the types of ties for and placement of reinforcing steel.*

Concrete is strong under compression, but relatively weak under tension. The reverse is true for steel. Therefore, when the two are combined, one makes up for the deficiency of the other. When steel is embedded in concrete in a manner that assists it in carrying imposed loads, the combination is known as reinforced concrete. The steel may consist of welded wire fabric or expanded metal mesh, but, more often, it consists of reinforcing bars, or more commonly “rebar.”

## WELDED WIRE FABRIC

Welded wire fabric, often referred to as “wire mesh,” comes in rolls and sheets. These must be cut to fit your individual application. The individual sections of fabric must be tied together, or “lapped,” to form a continuous sheet of fabric.

Specifications and designs are usually used when wire fabric is being lapped. However, as a rule of thumb, one complete lap is usually sufficient with a minimum of 2 inches between laps. Whenever the rule of thumb is not allowed, use the end lap or side lap method.

In the end lap method, the wire mesh is lapped by overlapping one full mesh measured from the end of the longitudinal wires in one piece to the end of longitudinal wires in the adjacent piece. The two pieces are then tied at 1 1/2-foot centers with a snap tie. In the side lap method, the two longitudinal side wires are placed one alongside and overlapping the other and then are tied with a snap tie every 3 feet.

## REINFORCING STEEL

Before placing reinforcing steel in forms, all form oiling should be completed. As mentioned earlier, oil or other coating should not contact the reinforcing steel in the formwork. Oil on reinforcing bars reduces the bond between the bars and the concrete. Use a piece of burlap to clean the bars of rust, scale, grease, mud, or other foreign matter. A light film of rust or mill scale is not objectionable.

Rebars must be tied together for the bars to remain in a desired arrangement during pouring. Tying is also a means of keeping laps or splices in place. Laps allow bond stress to transfer the load from one bar, first into the concrete and then into the second bar.

## Methods of Tying

Several types of ties can be used with rebar. Some are more effective than others. The views in figure 7-20 illustrate the six types used by the Seabees: (A) snap, or simple, tie, (B) wall tie, (C) double-strand tie, (D) saddle tie, (E) saddle tie with twist, and (F) cross, or figure-eight, tie. As a Builder, you will probably be concerned only with the snap

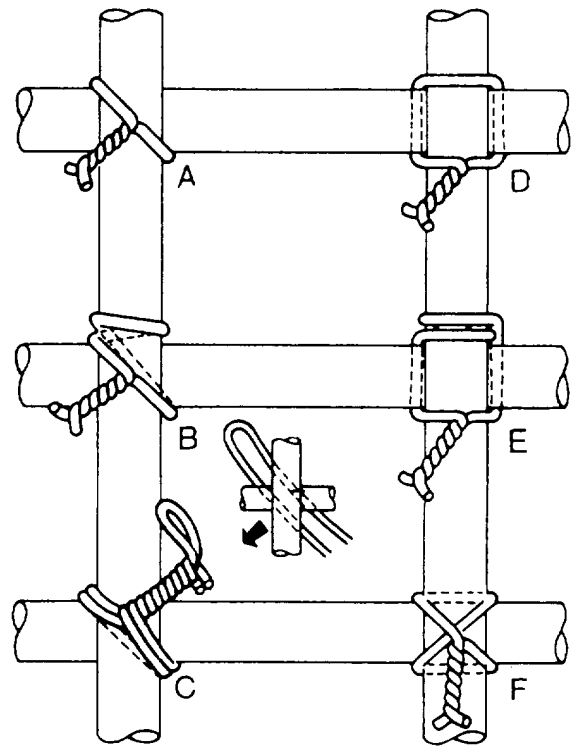

Figure 7-20.-Types of ties.



and saddle ties. However, as a professional, you should be familiar with all six types.

**SNAP, OR SIMPLE, TIE.**— The snap, or simple, tie (view A of figure 7-20) is simply wrapped once around the two crossing bars in a diagonal manner with the two ends on top. The ends are then twisted together with a pair of side cutters until they are very tight against the bars. Finally, the loose ends are cut off. This tie is used mostly on floor slabs.

**WALL TIE.**— The wall tie (view B of figure 7-20) is made by taking one and one-half turns around the vertical bar, then one turn diagonally around the intersection. The two ends are twisted together until the connection is tight, then the excess is cut off. The wall tie is used on light vertical mats of steel.

**DOUBLE-STRAND SINGLE TIE.**— The double-strand tie (view C) is a variation of the simple tie. It is favored in some localities and is especially used for heavy work.

**SADDLE TIE.**— The wires of the saddle tie (view D) pass half way around one of the bars on either side of the crossing bar and are brought squarely or diagonally around the crossing bar. The ends are then twisted together and cut off.

**SADDLE TIE WITH TWIST.**— The saddle tie with twist (view E) is a variation of the saddle tie.

The tie wire is carried completely around one of the bars, then squarely across and halfway around the other, either side of the crossing bars, and finally brought together and twisted either squarely or diagonally across. The saddle tie with twist is used for heavy mats that are to be lifted by crane.

**CROSS, OR FIGURE-EIGHT, TIE.**— The cross, or figure-eight, tie (view F) has the advantage of causing little or no twist in the bars.

**CARRYING WIRE.**— When tying reinforcing bars, you must have a supply of tie wire available. There are several ways you can carry your tie wire. One way is to coil it to a diameter of 18 inches, then slip it around your neck and under one arm (figure 7-21). This leaves a free end for tying. Coil enough wire so it weighs about 9 pounds.

Another way to carry tie wire is to take pieces of wire about 9-inches long, fold them, and hook one end in your belt. Then, you can pull the wires out as needed. The tools you use in tying reinforcing bars include a 6-foot folding rule, side cutters, leather gloves, 50-foot tape measure, and a keel crayon, either yellow, red, or blue.

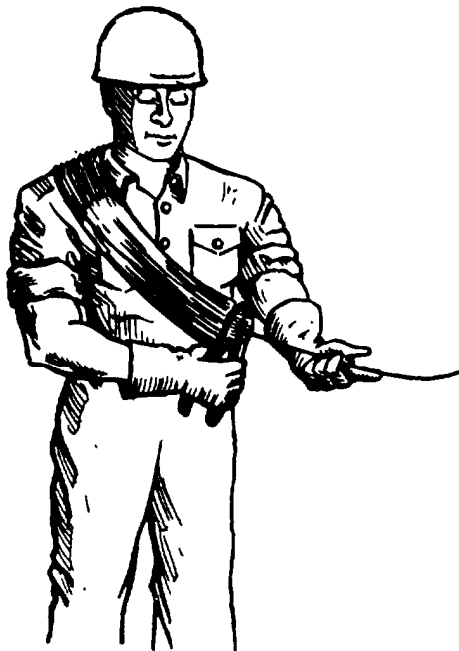

Figure 7-21.-Carrying tie wire.

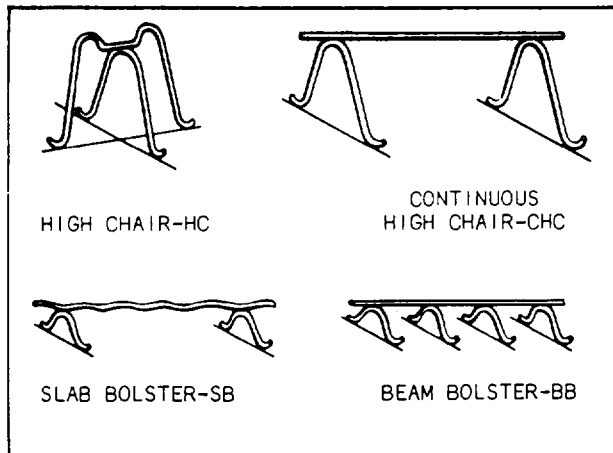

Figure 7-22.-Devices used to support horizontal reinforcing.

### Location for Reinforcing Steel

The proper location for reinforcing bars is given on the drawings. To ensure that the structure can withstand the loads it must carry, place the steel in exactly the position shown. Secure the bars in position so that they will not move when the concrete is placed. This can be accomplished by using the reinforcing bar supports shown in figures 7-22, 7-23, and 7-24.

Footings and other principal structural members that are against the ground should have at least 3

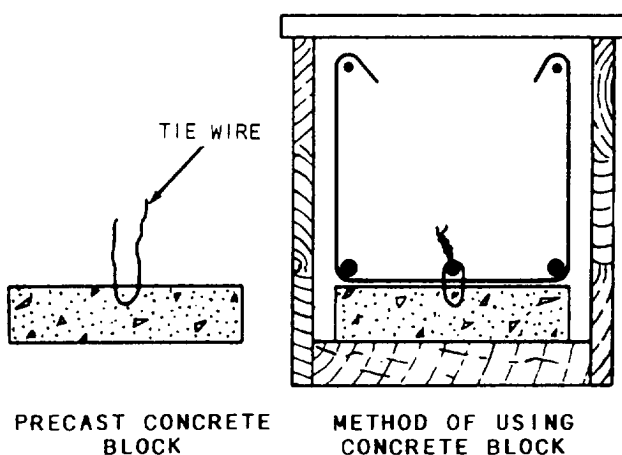

Figure 7-23.-Precast concrete block used for reinforcing steel support.

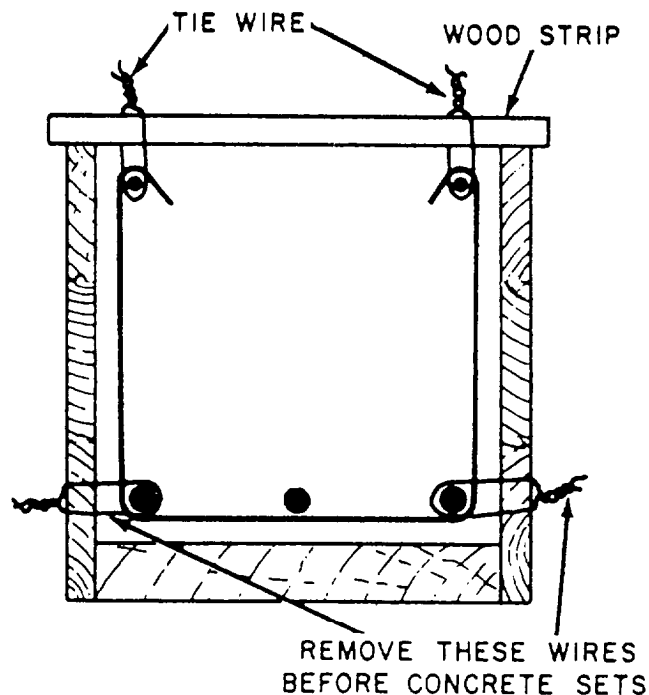

Figure 7-24.-Beam-reinforcing steel hung in place.

inches of concrete between steel and ground. If the concrete surface is to be in contact with the ground or exposed to the weather after removal of the forms, the protective covering of concrete over the steel should be 2 inches for bars larger than No. 5 and 1 1/2 inches for No. 5 or smaller. The protective covering maybe reduced to 1 1/2 inches for beams and columns and 3/4 inch for slabs and interior wall surfaces, but it should be 2 inches for all exterior wall surfaces.

The clear distance between parallel bars in beams, footings, walls, and floor slabs should be a minimum of 1 inch, or one and one-third times the largest size aggregate particle in the concrete. In columns, the clear distance between parallel bars should be a minimum of one and one-half times the bar diameter, one and one-half times the maximum size of the coarse aggregate, or not less than 1 1/2 inches.

The support for reinforcing steel in floor slabs is shown in figure 7-25. The height of the slab bolster is determined by the concrete protective cover required. Concrete blocks made of sand-cement mortar can be used in place of the slab bolster. Wood blocks should never be used for this purpose if there is any possibility the concrete might become wet and if the construction is of a permanent type. Bar chairs, like those shown in figure 7-25, are available from commercial sources in heights up to 6 inches. If a height greater than 6 inches is required, make the

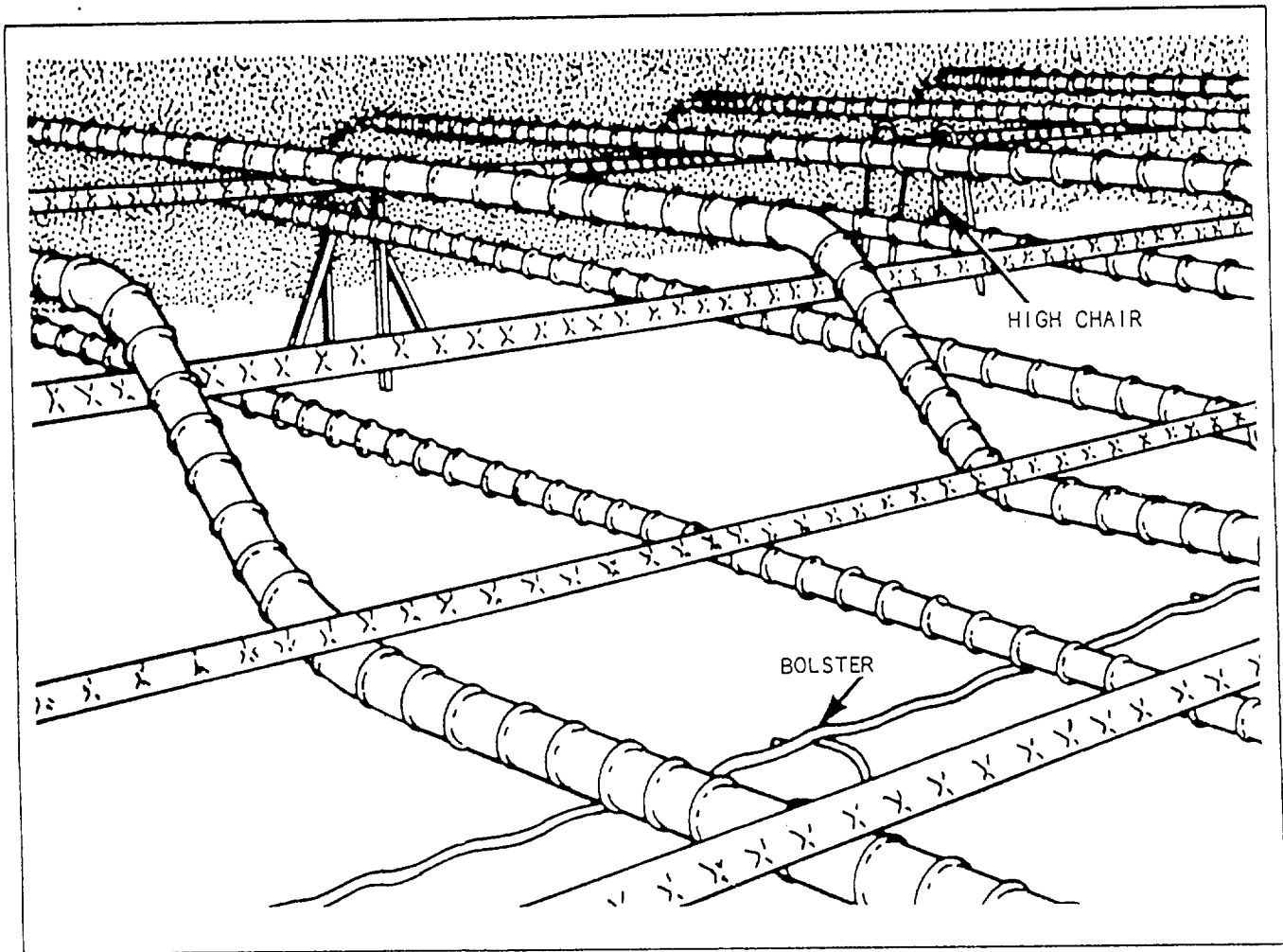

Figure 7-25.-Reinforcing steel for a floor slab.

chair of No. 0 soft annealed iron wire. Tie the bars together at frequent intervals with a snap tie to hold them firmly in position.

Steel for column ties can be assembled into cages by laying the vertical bars for one side of the column horizontally across a couple of sawhorses. The proper number of ties is slipped over the bars, the remaining vertical bars are added, and then the ties are spaced out as required by the placing plans. A sufficient number of intersections are wired together to make the assembly rigid. This allows it to be hoisted and set as a unit.

After the column form is raised, it is tied to the dowels or reinforcing steel carried up from below. This holds it firmly in position at the base. The column form is erected, and the reinforcing steel is tied to the column form at 5-foot intervals, as shown in figure 7-26.

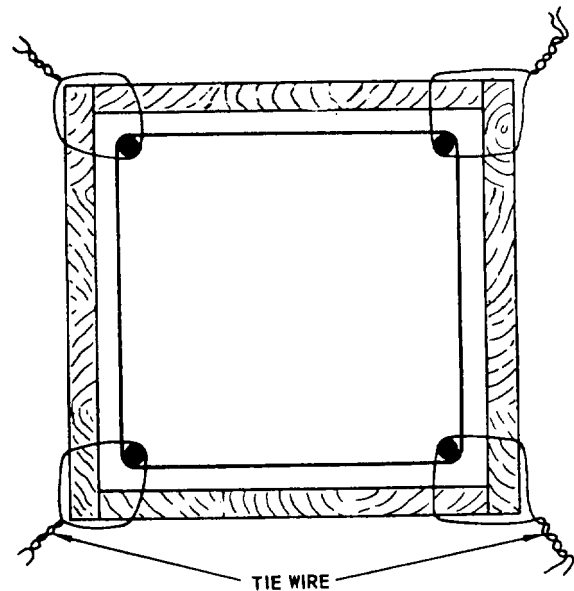

Figure 7-26.-Securing a column with reinforcing steel against displacement.

The use of metal supports to hold beam-reinforcing steel in position is shown in figure 7-27. Note the position of the beam bolster. The stirrups are tied to the main reinforcing steel with a snap tie. Whenever possible, you should assemble the stirrups and main reinforcing steel outside the form and then place the assembled unit in position. Wood blocks should be substituted for the metal supports only if there is no possibility of the concrete becoming wet or if the construction is known to be temporary. Precast concrete blocks, as shown in figure 7-23, may be substituted for metal supports or, if none of the types of bar supports described above seem suitable, the method shown in figure 7-24 may be used.

Placement of steel in walls is the same as for columns except that the steel is erected in place and not preassembled. Horizontal steel is tied to vertical steel at least three times in any bar length. Steel in place in a wall is shown in figure 7-28. The wood block is removed when the form has been filled up to the level of the block. For high walls, ties in between the top and bottom should be used.

Steel is placed in footings very much as it is placed in floor slabs. Stones, rather than steel supports, may be used to support the steel at the

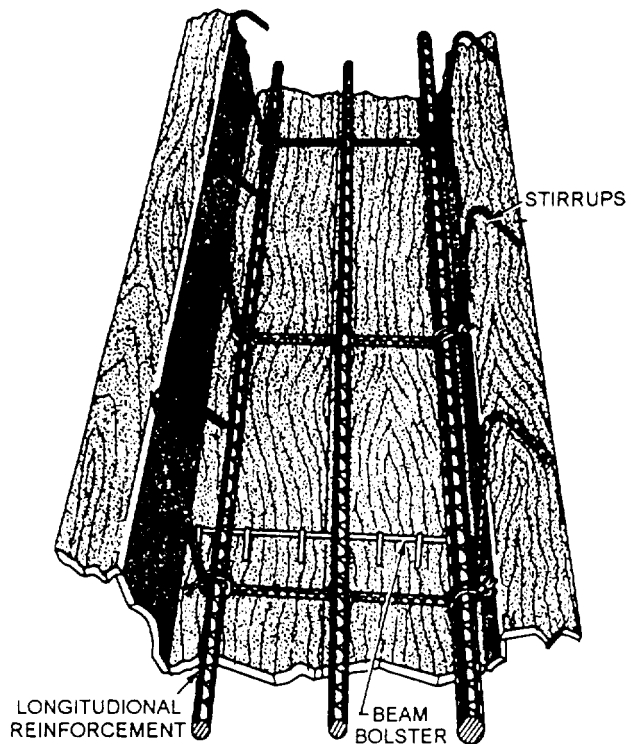

Figure 7-27.-Beam-reinforcing steel supported on beam bolsters.

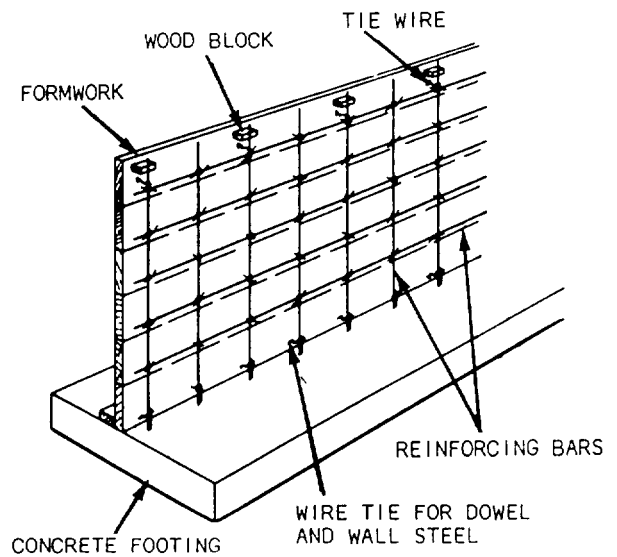

Figure 7-28.-Steel in place in a wall.

proper distance above the subgrade. Steel mats are generally preassembled and placed in small footings after the forms have been set. A typical arrangement is shown in figure 7-29. Steel mats in large footings are generally constructed in place.

Welded wire fabric (figure 7-30) is also used as limited reinforcement for concrete footings, walls, and slabs, but its primary use is to control crack widths due to temperature changes.

Form construction for each job has its peculiarities. However, certain natural conditions prevail in all situations. Wet concrete always develops hydrostatic pressure and strain on forms. Therefore, all stakes,

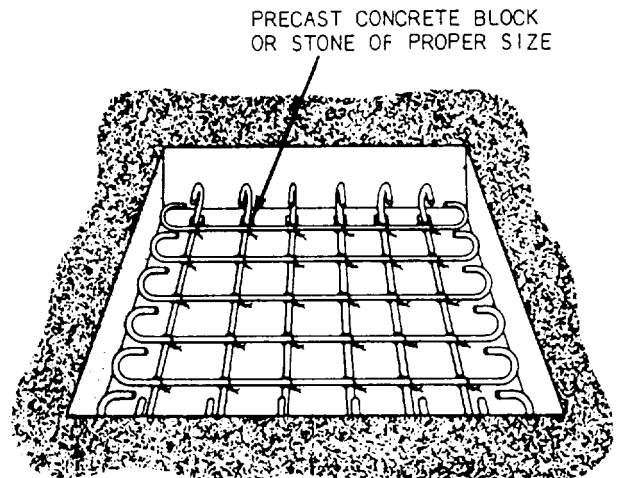

Figure 7-29.-Steel in place in a footing.

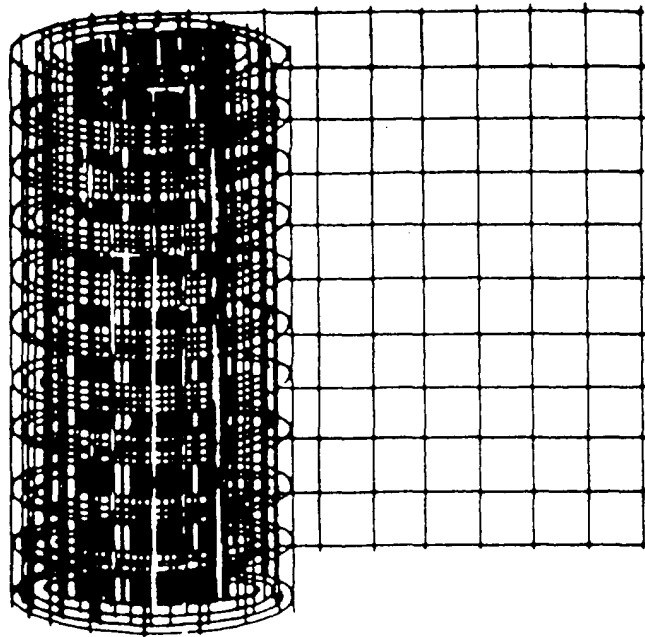

Figure 7-30.-Welded wire mesh fabric.

braces, walers, ties, and shebolts should be properly secured before placing concrete.

### Splicing Reinforcing Bar

Because rebar is available only in certain lengths, it must be spliced together for longer runs. Where splices are not dimensioned on the drawings, the bars should be lapped not less than 30 times the bar diameter, or not less than 12 inches.

The stress in a tension bar can be transmitted through the concrete and into another adjoining bar by a lap splice of proper length. The lap is expressed as the number of bar diameters. If the bar is No. 2, make the lap at least 12 inches. Tie the bars together with a snap tie (figure 7-31).

### CONCRETE CONSTRUCTION JOINTS

*LEARNING OBJECTIVE: Upon completing this section, you should be able to determine the location of construction joints.*

Concrete structures are subjected to a variety of stresses. These stresses are the result of shrinkage and differential movement. Shrinkage occurs during hydration, and differential movement is caused by temperature changes and different loading conditions. These stresses can cause cracking, spalling, and

scaling of concrete surfaces and, in extreme cases, can result in failure of the structure.

### TYPES OF JOINTS

Stresses in concrete can be controlled by the proper placement of joints in the structure. We'll discuss three basic types of joints: isolation joints, control joints, and construction joints.

#### Isolation Joints

Isolation joints are used to separate (isolate) adjacent structural members. An example is the joint that separates the floor slab from a column. An isolation joint allows for differential movement in the vertical plane due to loading conditions or uneven settlement. Isolation joints are sometimes called expansion or contraction joints. In this context, they allow for differential movement as a result of temperature changes (as in two adjacent slabs). All isolation joints (expansion or contraction) extend completely through the member and have no load



Figure 7-31.-Bars spliced by lapping.

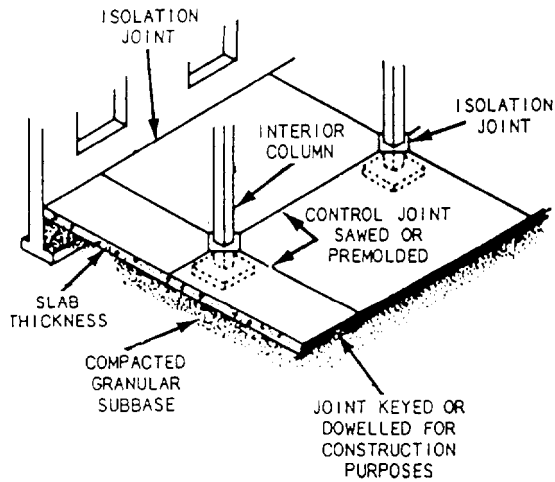

Figure 7-32.-Typical isolation and control joints.

transfer devices built into them. Examples of these are shown in figures 7-32, 7-33, and 7-34.

### Control Joints

Movement in the plane of a concrete slab is caused by drying shrinkage and thermal contraction. Some shrinkage is expected and can be tolerated, depending on the design and exposure of the particular structural elements. In a slab, shrinkage occurs more rapidly at the exposed surfaces and causes upward curling at the edges. If the slab is

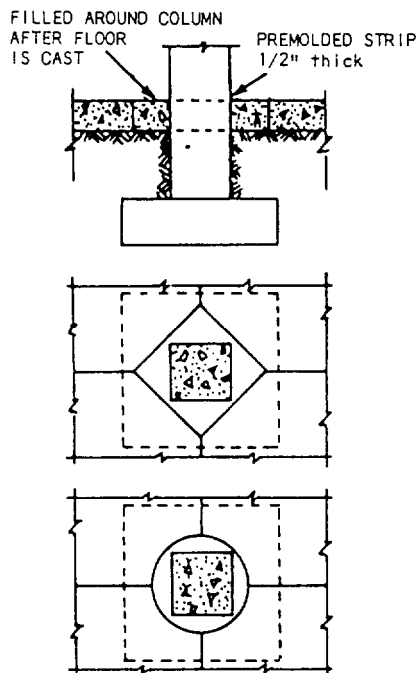

Figure 7-33.-Isolation joints at columns and walls.

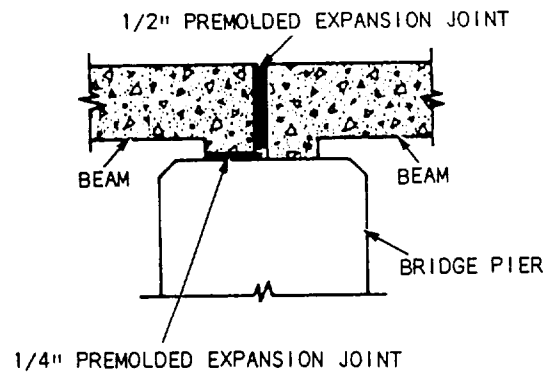

Figure 7-34.-Expansion/contraction joint for a bridge.

restrained from curling, cracking will occur wherever the restraint imposes stress greater than the tensile strength. Control joints (figure 7-35) are cut into the concrete slab to create a plane of weakness, which forces cracking (if it happens) to occur at a designated place rather than randomly. These joints run in both directions at right angles to each other. Control joints in interior slabs are typically cut 1/3 to 1/4 of the slab thickness and then filled with joint filler. See table 7-1 for suggested control joint spacings. Temperature steel (welded wire fabric) can be used to restrict crack width. For sidewalks and driveways, tooled joints spaced at intervals equal to the width of the slab, but not more than 20 feet (6 meters) apart, should be used. The joint should be 3/4 to 1 inch deep. Surface irregularities along the plane of the

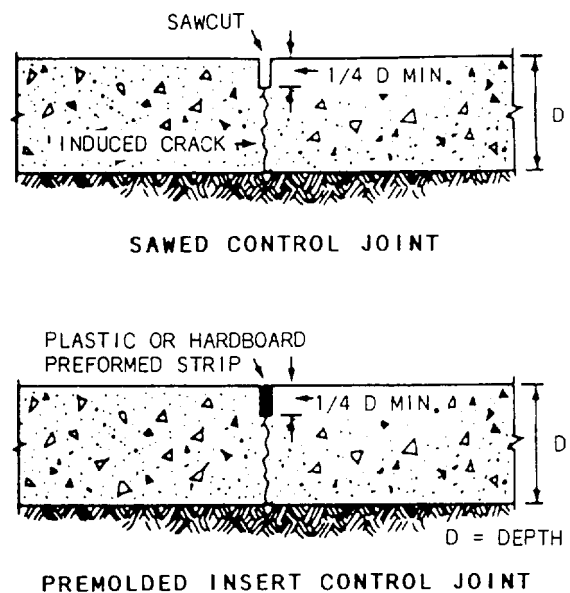

Figure 7-35.-Control joints.

Table 7-1.-Suggested Spacing of Control Joints

SLAB THICKNESS (IN)	LESS THAN 3/4 IN AGGREGATE: SPACING (FT)	LARGER THAN 3/4 IN AGGREGATE: SPACING (FT)	SLUMP LESS THAN 4 IN: SPACING (FT)
5	10*	13	15
6	12	15	18
7	14	18	21
8	16	20	24
9	18	23	27
10	20	25	30

\*Given spacings also apply to the distance from control joints to parallel isolation joints or to parallel construction joints. Refer to text for other factors that may call for different spacing.

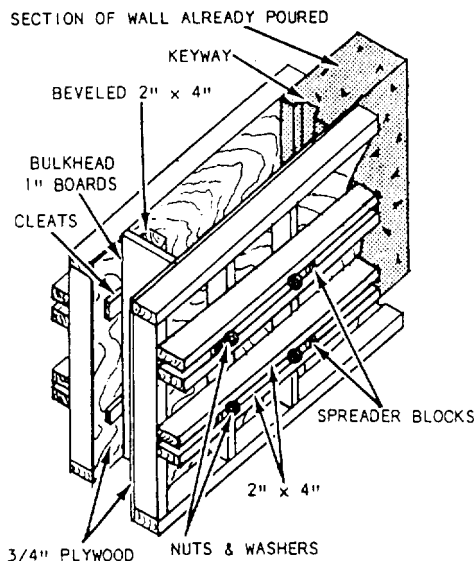

Figure 7-36.-Vertical bulkhead in wall using keyway.

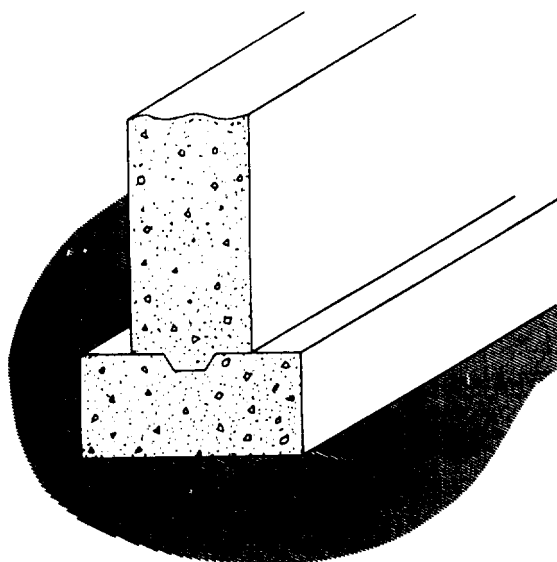

Figure 7-38.-Construction Joint between wall and footing with a keyway.

crack are usually sufficient to transfer loads across the joint in slabs on grade.

**Construction Joints**

Construction joints (figures 7-36,7-37,7-38, and 7-39) are made where the concrete placement

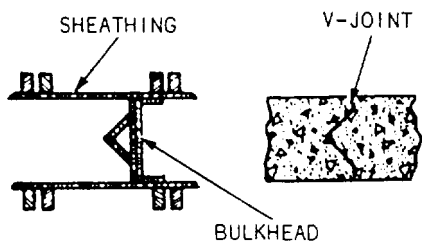

Figure 7-37.-Keyed wall construction joint.

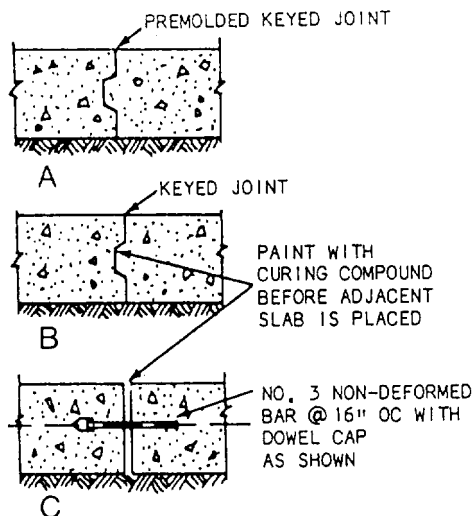

Figure 7-39.-Types of construction Joints.

operations end for the day or where one structural element is cast against previously placed concrete. These joints allow some load to be transferred from one structural element to another through the use of keys or (for some slabs and pavement) dowels. Note that the construction joint extends entirely through the concrete element.

## SAWING CONCRETE

*LEARNING OBJECTIVE: Upon completing this section, you should be able to determine proper occasions for using the concrete saw.*

### THE CONCRETE SAW

The concrete saw is used to cut longitudinal and transverse joints in finished concrete pavements. The saw is small and can be operated by one person (figure 7-40). Once the cut has been started, the machine provides its own tractive power. A water spray is used to flush the saw cuttings from the cutting area and to cool the cutting blade.

Several types of blades are available. The most common blades have either diamond or Carborundum cutting surfaces. The diamond blade is used for cutting hard or old concrete; the Carborundum blade is used for cutting green concrete (under 30 hours old). Let's take a closer look at these two blades.

#### DIAMOND BLADES

Diamond blades have segments made from a sintered mixture of industrial diamonds and metal powders, which are brazed to a steel disk. They are generally used to cut old concrete, asphalt, and green concrete containing the harder aggregates. Diamond blades must always be used wet. Many grades of diamond blades are available to suit the conditions of the job.

Twelve-inch-diameter diamond blades are the most popular size. This size makes a cut about 3 1/4-inches deep. Larger-size blades are used for deeper cuts.

#### CARBORUNDUM BLADES

Low-cost, abrasive blades are now widely used to cut green concrete made with soft aggregates, such as limestone, dolomite, coral, or slag. These blades are made from a mixture of silicon carbide grains and a resin bond. This mixture is pressed and baked. In

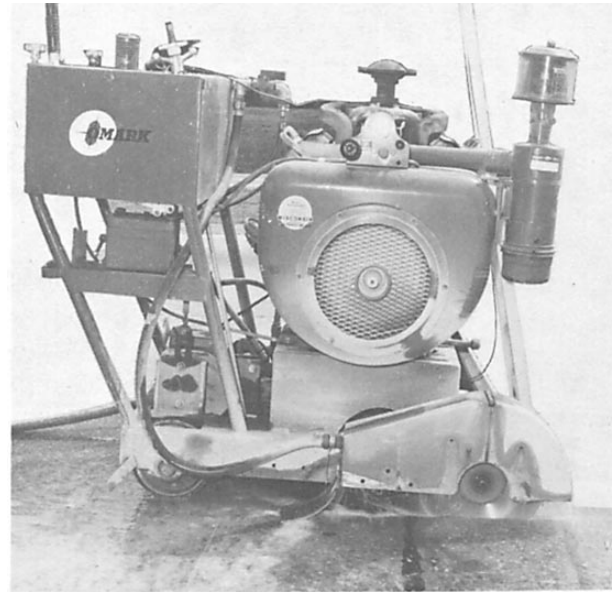

133.18

**Figure 7-40.-Concrete saw.**

and baked. In many cases, some of the medium-hard aggregates can be cut if the step-cutting method is used. This method uses two or more saws to cut the same joint, each cutting only a part of the total depth. This principle is also used on the longitudinal saw, which has two individually adjustable cutting heads. When a total depth of 2 1/2 inches is to be cut, the leading blade cuts the first inch and the trailing blade, which is slightly narrower, cuts the remaining depth.

Abrasive blades come in 14- and 18-inch diameters. They are made in various thicknesses to cut joints from 1/4-inch to 1/2-inch wide.

#### When to Use

When is the best time to saw green concrete? In the case of abrasive blades, there is only one answer—as soon as the concrete can support the equipment and the joint can be cut with a minimum of chipping. In the case of diamond blades, two factors must be considered. In the interest of blade life, sawing should be delayed, but control of random cracking requires sawing at the transverse joints as early as possible. Where transverse joints are closely spaced, every second or third joint can be cut initially and the rest cut later. Sawing longitudinal joints can be delayed for 7 days or longer.

For proper operation and maintenance of the concrete saw, follow the manufacturer's manual.



## PLACING CONCRETE

*LEARNING OBJECTIVE: Upon completing this section, you should be able to describe the proper placing procedures for well-designed concrete.*

You cannot obtain the full value of well-designed concrete without using proper placing procedures. Good concrete placing and compacting techniques produce a tight bond between the paste and aggregate and fill the forms completely. Both of these factors contribute to the full strength and best appearance of concrete. The following are some of the principles of concrete placement:

- **Segregation**— Avoid segregation during all operations, from the mixer to the point of placement, including final consolidation and finishing.
- **Consolidation**— Thoroughly consolidate the concrete, working solidly around all embedded

reinforcement and filling all form angles and corners.

- **Bonding**— When placing fresh concrete against or upon hardened concrete, make sure that a good bond develops.
- **Temperature control**— Take appropriate steps to control the temperature of fresh concrete from mixing through final placement. Protect the concrete from temperature extremes after placement.
- **Maximum drop**— To save time and effort, you may be tempted to simply drop the concrete directly from the delivery chute regardless of form height. However, unless the free fall into the form is less than 4 feet, use vertical pipes, suitable drop chutes, or baffles. Figure 7-41 suggests several ways to control concrete fall. Good control prevents honeycombing and other undesirable results.

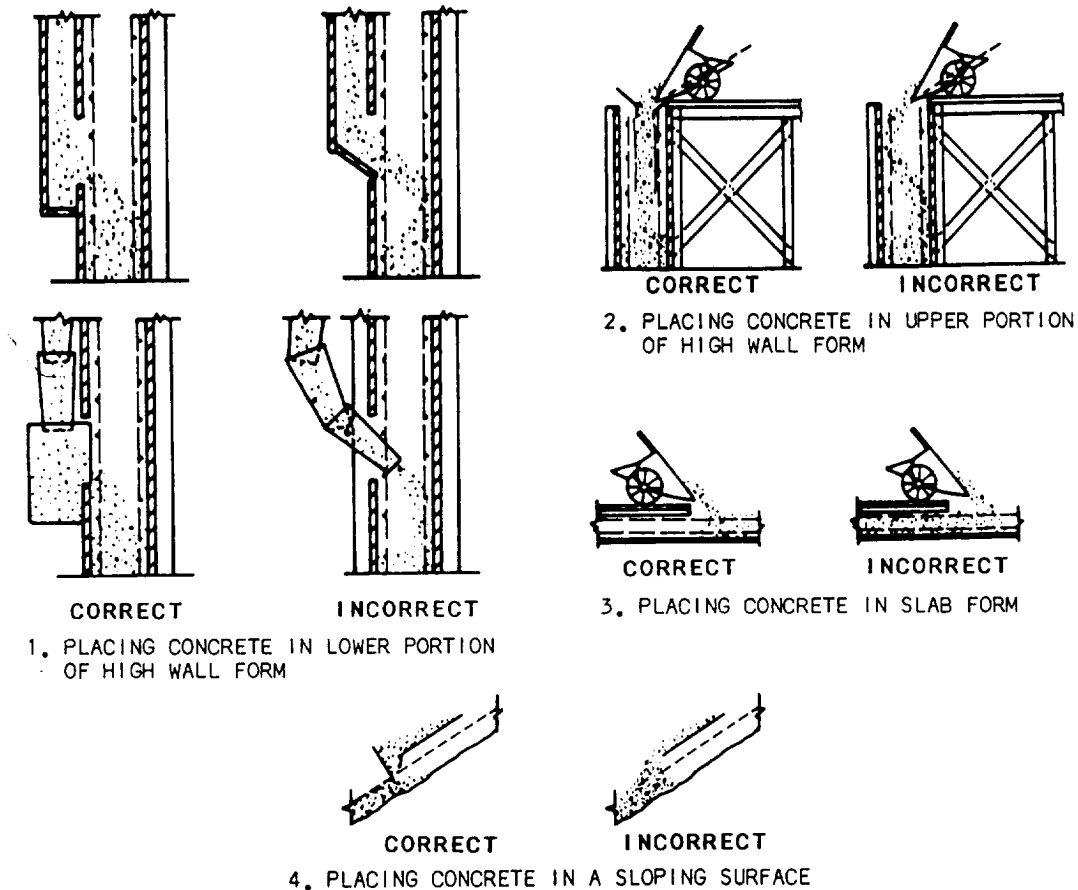

Figure 7-41.-Concrete placing techniques.

- **Layer thickness**— Try to place concrete in even horizontal layers. Do not attempt to puddle or vibrate it into the form. Place each layer in one operation and consolidate it before placing the next layer to prevent honeycombing and voids. This is particularly critical in wall forms containing considerable reinforcement. Use a mechanical vibrator or a hand spading tool for consolidation. Take care not to over vibrate. This can cause segregation and a weak surface. Do not allow the first layer to take its initial set before adding the next layer. Layer thickness depends on the type of construction, the width of the space between forms, and the amount of reinforcement.
- **Compacting**— (Note: This is different from soil compaction.) First, place concrete into its final position as nearly as possible. Then, work the concrete thoroughly around reinforcement and imbedded fixtures, into the corners, and against the sides of the forms. Because paste tends to flow ahead of aggregate, avoid horizontal movements that result in segregation.
- **Placing rate**— To avoid excessive pressure on large project forms, the filling rate should not exceed 4 vertical feet per hour, except for columns. Coordinate the placing and compacting so that the concrete is not deposited faster than it can be compacted properly. To avoid cracking during settlement, allow an interval of at least 4 hours, preferably 24 hours, between placing slabs, beams, or girders, and placing the columns and walls they support.
- **Wall construction**— When constructing walls, beams, or girders, place the first batches of each layer at the ends of the section, then proceed toward the center to prevent water from collecting at the form ends and corners. For walls, stop off the inside form at the construction level. Overfill the form for about 2 inches and remove the excess just before the concrete sets to ensure a rough, clean surface. Before placing the next lift of concrete, deposit a 1/2- to 1-inch-thick layer of sand-cement mortar. Make the mortar with the same water content ratio as the concrete and with a 6-inch slump to prevent stone pockets and help produce a watertight joint. View 1 of figure 7-41 shows the proper way to place concrete in the lower portion of high wall forms. Note the different types of drop chute that can be used to place concrete through port openings and into the lower portion of the wall. Space the port openings at about 10-foot intervals up the wall. The method used to place concrete in the upper portion of the wall is shown in view 2 of figure 7-41. When placing concrete for walls, be sure to remove the spreaders as you fill the forms.
- **Slab construction**— When constructing slabs, place the concrete at the far end of the slab first, and then place subsequent batches against previously placed concrete, as shown in view 3 of figure 7-41. Do not place the concrete in separate piles and then level the piles and work them together. Also, don't deposit the concrete in piles and then move them horizontally to their final position. These practices can result in segregation.
- **Placing concrete on slopes**— View 4 of figure 7-41 shows how to place concrete on slopes. Always deposit the concrete at the bottom of the slope first, then proceed up the slope placing each new batch against the previous one. When consolidated, the weight of the new concrete increases the compacting of the previously placed concrete.

## CONSOLIDATING CONCRETE

*LEARNING OBJECTIVE: Upon completing this section, you should be able to describe the methods available for consolidating concrete.*

Except for concrete placed underwater, you must compact or consolidate all concrete after placement.

## PURPOSE OF CONSOLIDATION

Consolidation eliminates rock pockets and air bubbles and brings enough fine material both to the surface and against the forms to produce the desired finish. You can use such hand tools as spades, puddling sticks, or tampers, but mechanical vibrators are best. Any compacting device must reach the bottom of the form and be small enough to pass between reinforcing bars. The process involves carefully working around all reinforcing steel with the compacting device to assure proper embedding of the reinforcing steel in the concrete. Since the strength of

the concrete member depends on proper reinforcement location, be careful not to displace the reinforcing steel.

## VIBRATION

Vibrators consolidate concrete by pushing the coarse aggregate downward, away from the point of vibration. Vibrators allow placement of mixtures that are too stiff to place any other way, such as those having a 1- or 2-inch slump. Stiff mixtures are more economical because they require less cement and present fewer segregation or bleeding problems. However, do not use a mix so stiff that it requires too much labor to place it.

### Mechanical Vibrators

The best compacting tool is a mechanical vibrator (figure 7-42). The best vibrators available in engineering construction battalions are called internal vibrators because the vibrating element is inserted into the concrete. When using an internal vibrator, insert it at approximately 18-inch intervals into air-entrained concrete for 5 to 10 seconds and into nonair-entrained concrete for 10 to 15 seconds. The exact period of time that you should leave a vibrator in the concrete depends on its slump. Overlap the

vibrated areas somewhat at each insertion. Whenever possible, lower the vibrator into the concrete vertically and allow it to descend by gravity. The vibrator should not only pass through the layer just placed, but penetrate several inches into the layer underneath to ensure a good bond between the layers.

Vibration does not normally damage the lower layers, as long as the concrete disturbed in these lower layers becomes plastic under the vibrating action. You know that you have consolidated the concrete properly when a thin line of mortar appears along the form near the vibrator, the coarse aggregate disappears into the concrete, or the paste begins to appear near the vibrator head. Then, withdraw the vibrator vertically at about the same gravity rate that it descended.

Some hand spading or puddling should accompany all vibration. To avoid the possibility of segregation, do not vibrate mixes that you can consolidate easily by spading. Also, don't vibrate concrete that has a slump of 5 inches or more. Finally, do not use vibrators to move concrete in the form.

### Hand Methods

Manual consolidation methods require spades, puddling sticks, or various types of tampers. To

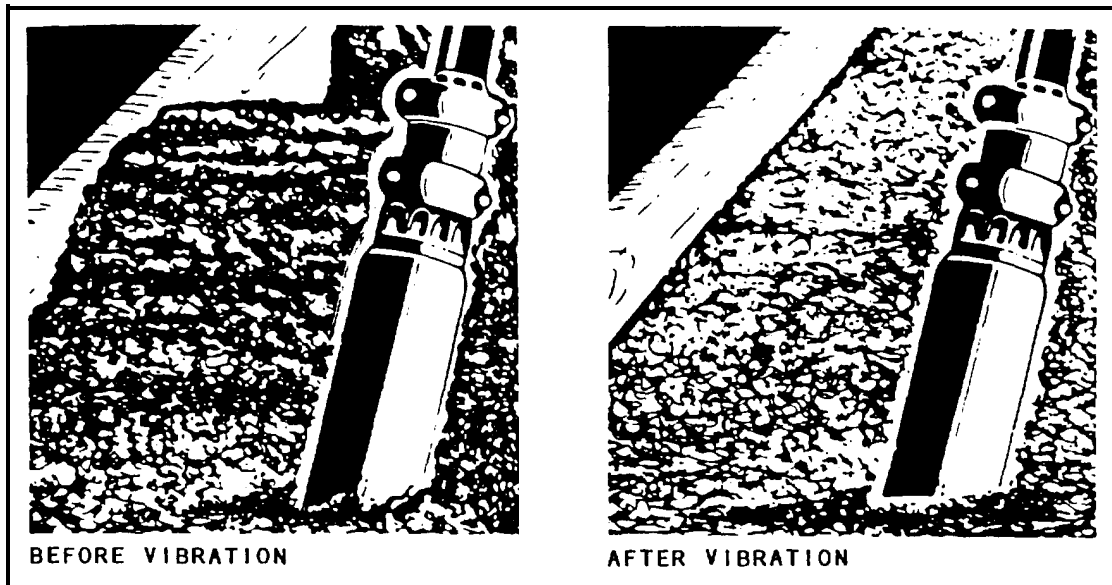

Figure 7-42.-Using a vibrator to consolidate concrete.

consolidate concrete by spading, insert the spade along the inside surface of the forms (figure 7-43), through the layer just placed, and several inches into the layer underneath. Continue spading or puddling until the coarse aggregate disappears into the concrete.

## FINISHING CONCRETE

*LEARNING OBJECTIVE: Upon completing this section, you should be able to describe the finishing process for the final concrete surface.*

The finishing process provides the final concrete surface. There are many ways to finish concrete surfaces, depending on the effect required. Sometimes you only need to correct surface defects, fill bolt holes, or clean the surface. Unformed surfaces may require only screeding to proper contour and elevation, or a broomed, floated, or trowelled finish may be specified.

## SCREEDING

The top surface of a floor slab, sidewalk, or pavement is rarely placed at the exact specified elevation. Screeding brings the surface to the required elevation by striking off the excess concrete. Two types of screeds are used in concrete finishing operations: the hand screed and the mechanical screed.

### Hand Screed

Hand screeding requires a tool called a screed. This is actually a templet (usually a 2-by-4) having a straight lower edge to produce a flat surface (or a curved lower edge to produce a curved surface). Move the screed back and forth across the concrete using a sawing motion, as shown in figure 7-44. With each sawing motion, move the screed forward an inch or so along the forms. This forces the concrete built up against the screed face into the low spots. If the screed tends to tear the surface, as it may on air-entrained concrete due to its sticky nature, either reduce the rate of forward movement or cover the lower edge of the screed with metal. This stops the tearing action in most cases.

You can hand-screed surfaces up to 30-feet wide, but the efficiency of this method diminishes on

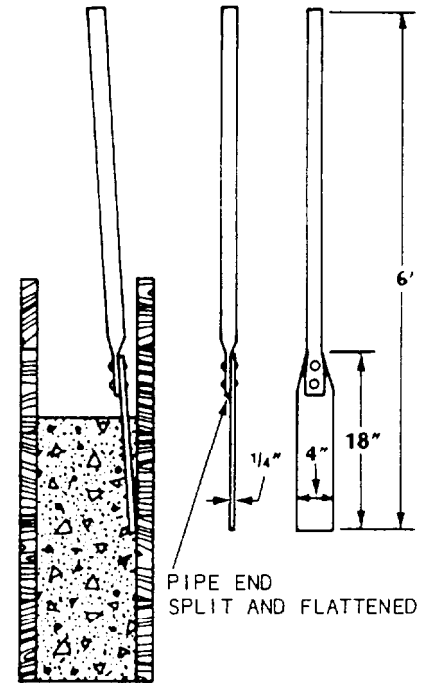

Figure 7-43.-Consolidation by spading and a spading tool.

surfaces more than 10-feet wide. Three workers (excluding a vibrator operator) can screed approximately 200 square feet of concrete per hour. Two of the workers work the screed while the third pulls excess concrete from the front of the screed. You must screed the surface a second time to remove the surge of excess concrete caused by the first screeding.

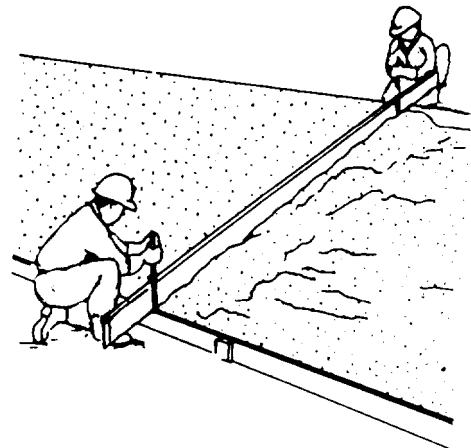

Figure 7-44.-Screeding operation.

## Mechanical Screed

The mechanical screed is being used more and more in construction for striking off concrete slabs on highways, bridge decks, and deck slabs. This screed incorporates the use of vibration and permits the use of stronger, and more economical, low-slump concrete. It can strike off this relatively dry material smoothly and quickly. The advantages of using a vibrating screed are greater density and stronger concrete. Vibrating screeds give a better finish, reduce maintenance, and save considerable time due to the speed at which they operate. Vibrating screeds are also much less fatiguing to operate than hand screeds.

A mechanical screed (figure 7-45) usually consists of a beam (or beams) and a gasoline engine, or an electric motor and a vibrating mechanism mounted in the center of the beam. Most mechanical screeds are quite heavy and usually equipped with wheels to help move them around. You may occasionally encounter lightweight screeds not equipped with wheels. These are easily lifted by two crewmembers and set back for the second pass if required.

The speed at which the screed is pulled is directly related to the slump of the concrete—the less the slump, the slower the speed; the more the slump, the faster the speed. On the finishing pass of the screed, there should be no transverse (crosswise) movement of the beam; the screed is merely drawn directly forward riding on the forms or rails. For a mechanical screed, a method is provided to quickly start or stop the vibration. This is important to prevent over vibration when the screed might be standing still.

Concrete is usually placed 15 to 20 feet ahead of the screed and shoveled as close as possible to its final resting place. The screed is then put into operation and pulled along by two crewmembers, one at each end of the screed. It is important that sufficient concrete is kept in front of the screed. Should the concrete be below the level of the screed beam, voids or bare spots will appear on the concrete surface as the screed passes over the slab. Should this occur, a shovelful or so of concrete is thrown on the bare spot, and the screed is lifted up and earned back past this spot for a second pass. In rare cases, the screed crew will work out the void or bare spot with a hand-operated bull float, rather than make a second pass with the screed.

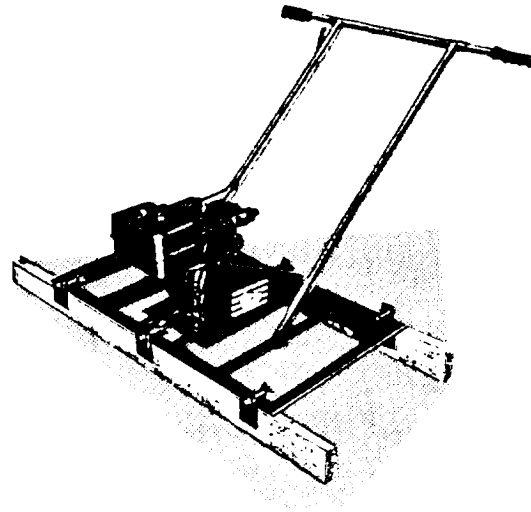

Figure 7-45.-Mechanical screed.

The vibration speed will need to be adjusted for particular mixes and different beam lengths. Generally, the stiffer the mix and the longer the beam, the greater the vibration speed required. The speed at which the screed is moved also affects the resulting finish of the slab. After a few minutes of operation, a satisfactory vibration pulling speed can be established. After the vibrating screed has passed over the slab, the surface is then ready for broom or burlap finishing.

Where possible, it is advisable to lay out or engineer the concrete slab specifically for use of a vibrating screed. Forms should be laid out in lanes of equal widths, so that the same-length screed can be used on all lanes or slabs. It should also be planned, if possible, that any vertical columns will be next to the forms, so that the screed can easily be lifted or maneuvered around the column.

There are four important advantages of using a vibrating finishing screed. First, it allows the use of low-slump concrete, resulting in stronger slabs. Second, it reduces and sometimes eliminates the necessity of hand tamping and bull floating. Third, it increases the density of the concrete, resulting in a superior wearing surface. And fourth, in the case of floor slabs, troweling can begin sooner since drier mixes can be used, which set up more quickly.

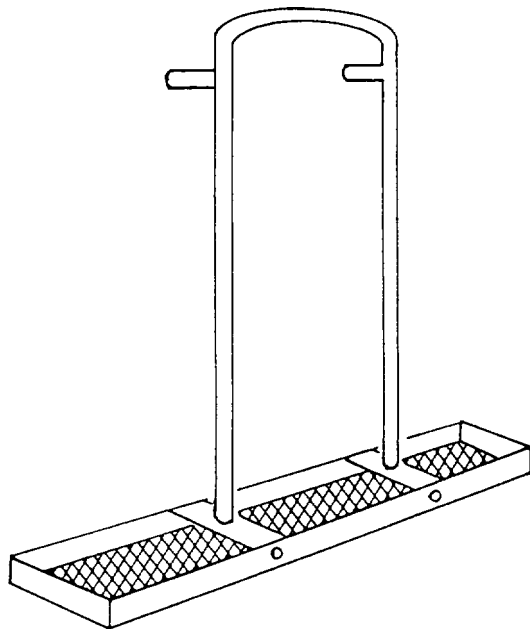

Figure 7-46.-Hand tamp (Jitterbug).

## HAND TAMPING

Hand tamping, or jitterbugging (figure 7-46), is done after the concrete has been screeded. Hand tamping is used to compact the concrete into a dense mass and to force the larger particles of coarse aggregate slightly below the surface. This enables you to put the desired finish on the surface. The tamping tool should be used only with a low-slump concrete, and bring only just enough mortar to the surface for proper finish. After using the jitterbug, you can go directly to using the bull float.

## FLOATING

If a smoother surface is required than the one obtained by screeding, the surface should be worked sparingly with a wood or aluminum magnesium float (figure 7-47, view A) or with a finishing machine. In view B, the wood float is shown in use. A long-handled wood float is used for slab construction (view C). The aluminum float, which is used the same way as the wood float, gives the finished concrete a much smoother surface. To avoid cracking and dusting of the finished concrete, begin aluminum floating when the water sheen disappears from the

freshly placed concrete surface. Do not use cement or water as an aid in finishing the surface.

Floating has three purposes: (1) to embed aggregate particles just beneath the surface; (2) to remove slight imperfections (high and low spots); and, (3) to compact the concrete at the surface in preparation for other finishing operations.

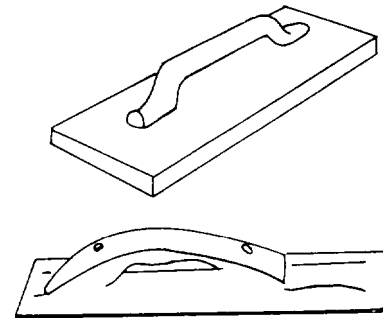

A. WOOD OR MAGNESIUM FLOAT

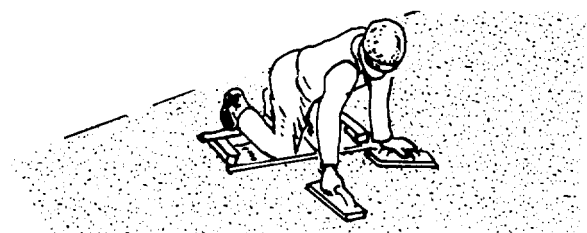

B. FLOATING OPERATION

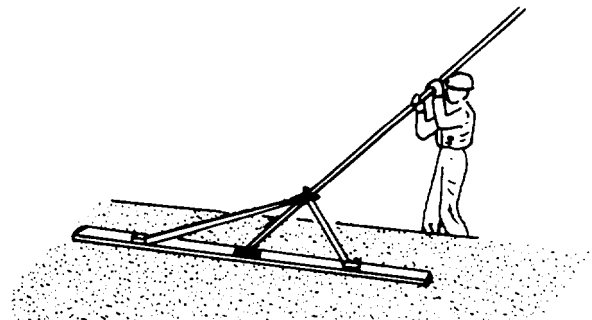

C. LONG-HANDLED WOOD FLOAT AND FLOATING OPERATION

Figure 7-47.-Wood floats and floating operations.

Begin floating immediately after screeding while the concrete is still plastic and workable. However, do not overwork the concrete while it is still plastic because you may bring an excess of water and paste to the surface. This fine material forms a thin, weak layer that will scale or quickly wear off under use. To remove a coarse texture as the final finish, you usually have to float the surface a second time after it partially hardens.

## EDGING

As the sheen of water begins to leave the surface, edging should begin. All edges of a slab that do not abut another structure should be finished with an edger (figure 7-48). An edger dresses corners and rounds or bevels the concrete edges. Edging the slab helps prevent chipping at the corners and helps give the slab a finished appearance.

## TROWELING

If a dense, smooth finish is desired, floating must be followed by steel troweling (figure 7-49). Troweling should begin after the moisture film or sheen disappears from the floated surface and when the concrete has hardened enough to prevent fine material and water from being worked to the surface. This step should be delayed as long as possible. Troweling too early tends to produce crazing and lack of durability. However, too long a delay in troweling results in a surface too hard to finish properly. The usual tendency is to start to trowel too soon. Troweling should leave the surface smooth, even, and free of marks and ripples. Spreading dry cement on a wet surface to take up excess water is not a good practice where a wear-resistant and durable surface is

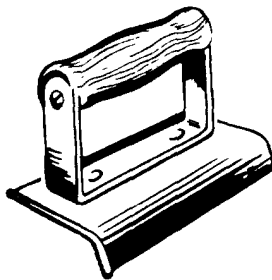

Figure 7-48.-Edger.

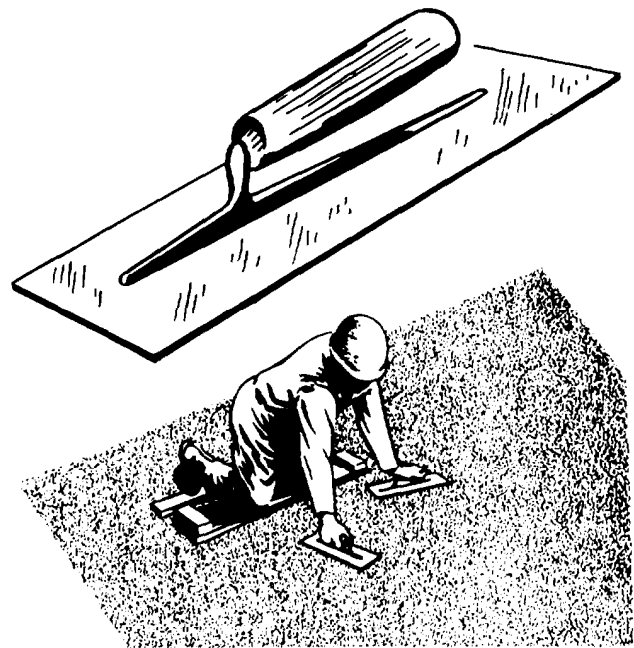

Figure 7-49.-Steel finishing tools and troweling operations.

required. Wet spots must be avoided if possible. When they do occur, however, finishing operations should not be resumed until the water has been absorbed, has evaporated, or has been mopped up.

## Steel Trowel

An unslippery, fine-textured surface can be obtained by troweling lightly over the surface with a circular motion immediately after the first regular troweling. In this process, the trowel is kept flat on the surface of the concrete. Where a hard steel-troweled finish is required, follow the first regular troweling by a second troweling. The second troweling should begin after the concrete has become hard enough so that no mortar adheres to the trowel, and a ringing sound is produced as the trowel passes over the surface. During this final troweling, the trowel should be tilted slightly and heavy pressure exerted to thoroughly compact the surface. Hairline cracks are usually due to a concentration of water and extremely fine aggregates at the surface. This results from overworking the concrete during finishing operations. Such cracking is aggravated by drying and cooling too rapidly. Checks that develop before troweling can usually be closed by pounding the concrete with a hand float.

## Mechanical Troweling Machine

The mechanical troweling machine (figure 7-50) is used to good advantage on flat slabs with a stiff consistency. Mechanical trowels come with a set of float blades that slip over the steel blades. With these blades, you can float a slab with the mechanical trowels. The concrete must be set enough to support the weight of the machine and the operator. Machine finishing is faster than hand finishing. However, it cannot be used with all types of construction. Refer to the manufacturer's manual for operation and maintenance of the machine you are using.

## BROOMING

A nonskid surface can be produced by brooming the concrete before it has thoroughly hardened. Brooming is carried out after the floating operation. For some floors and sidewalks where scoring is not desirable, a similar finish can be produced with a hairbrush after the surface has been troweled once. Where rough scoring is required, a stiff broom made of steel wire or coarse fiber should be used. Brooming should be done so that the direction of the scoring is at right angles to the direction of the traffic.

## GRINDING

When grinding of a concrete floor is specified, it should be started after the surface has hardened sufficiently to prevent dislodgement of aggregate particles and should be continued until the coarse aggregate is exposed. The machines used should be of an approved type with stones that cut freely and rapidly. The floor is kept wet during the grinding process, and the cuttings are removed by squeegeeing and flushing with water.

After the surface is ground, air holes, pits, and other blemishes are filled with a thin grout composed of one part No. 80-grain carborundum grit and one part portland cement. This grout is spread over the floor and worked into the pits with a straightedge. Next, the grout is rubbed into the floor with the grinding machine. When the filings have hardened for 17 days, the floor receives a final grinding to remove the film and to give the finish a polish. All surplus material is then removed by washing thoroughly. When properly constructed of good-quality materials, ground floors are dustless, dense, easily cleaned, and attractive in appearance.

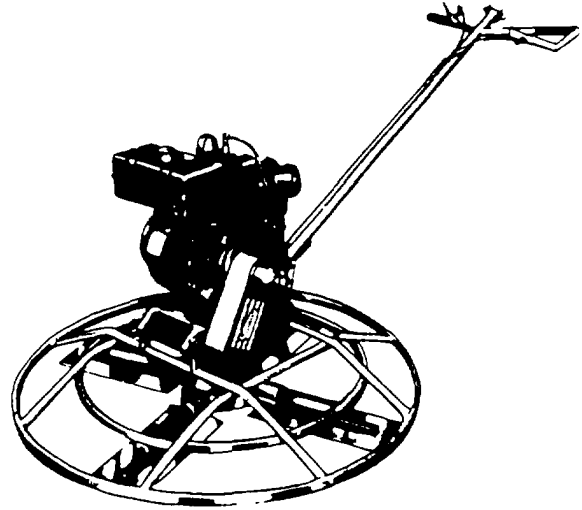

Figure 7-50.-Mechanical troweling machine.

## SACK-RUBBED FINISH

A sack-rubbed finish is sometimes necessary when the appearance of formed concrete falls considerably below expectations. This treatment is performed after all required patching and correction of major imperfections have been completed. The surfaces are thoroughly wetted, and sack rubbing is commenced immediately.

The mortar used consists of one part cement; two parts, by volume, of sand passing a No. 16 screen; and enough water so that the consistency of the mortar will be that of thick cream. It may be necessary to blend the cement with white cement to obtain a color matching that of the surrounding concrete surface. The mortar is rubbed thoroughly over the area with clean burlap or a sponge rubber float, so that it fills all pits. While the mortar in the pits is still plastic, the surface should be rubbed over with a dry mix of the same material. This removes all excess plastic material and places enough dry material in the pits to stiffen and solidify the mortar. The filings will then be flush with the surface. No material should remain on the surface above the pits. Curing of the surface is then continued.

## RUBBED FINISH

A rubbed finish is required when a uniform and attractive surface must be obtained. A surface of satisfactory appearance can be obtained without



rubbing if plywood or lined forms are used. The first rubbing should be done with coarse carborundum stones as soon as the concrete has hardened so that the aggregate is not pulled out. The concrete should then be cured until final rubbing. Finer carborundum stones are used for the final rubbing. The concrete should be kept damp while being rubbed. Any mortar used in this process and left on the surface should be kept damp for 1 to 2 days after it sets to cure properly. The mortar layer should be kept to a minimum thickness as it is likely to scale off and mar the appearance of the surface.

### EXPOSED AGGREGATE FINISH

An exposed aggregate finish provides a nonskid surface. To obtain this, you must allow the concrete to harden sufficiently to support the finisher. The aggregate is exposed by applying a retarder over the surface and then brushing and flushing the concrete surface with water. Since timing is important, test panels should be used to determine the correct time to expose the aggregate.

### CURING CONCRETE

Adding water to Portland cement to form the water-cement paste that holds concrete together starts a chemical reaction that makes the paste into a bonding agent. This reaction, called hydration, produces a stone-like substance—the hardened cement paste. Both the rate and degree of hydration, and the resulting strength of the final concrete, depend on the curing process that follows placing and consolidating the plastic concrete. Hydration continues indefinitely at a decreasing rate as long as the mixture contains water and the temperature conditions are favorable. Once the water is removed, hydration ceases and cannot be restarted.

Curing is the period of time from consolidation to the point where the concrete reaches its design strength. During this period, you must take certain steps to keep the concrete moist and as near 73°F as practical. The properties of concrete, such as freeze and thaw resistance, strength, watertightness, wear resistance, and volume stability, cure or improve with age as long as you maintain the moisture and

temperature conditions favorable to continued hydration.

The length of time that you must protect concrete against moisture loss depends on the type of cement used, mix proportions, required strength, size and shape of the concrete mass, weather, and future exposure conditions. The period can vary from a few days to a month or longer. For most structural use, the curing period for cast-in-place concrete is usually 3 days to 2 weeks. This period depends on such conditions as temperature, cement type, mix proportions, and so forth. Bridge decks and other slabs exposed to weather and chemical attack usually require longer curing periods. Figure 7-51 shows how moist curing affects the compressive strength of concrete.

### Curing Methods

Several curing methods will keep concrete moist and, in some cases, at a favorable hydration temperature. They fall into two categories: those that

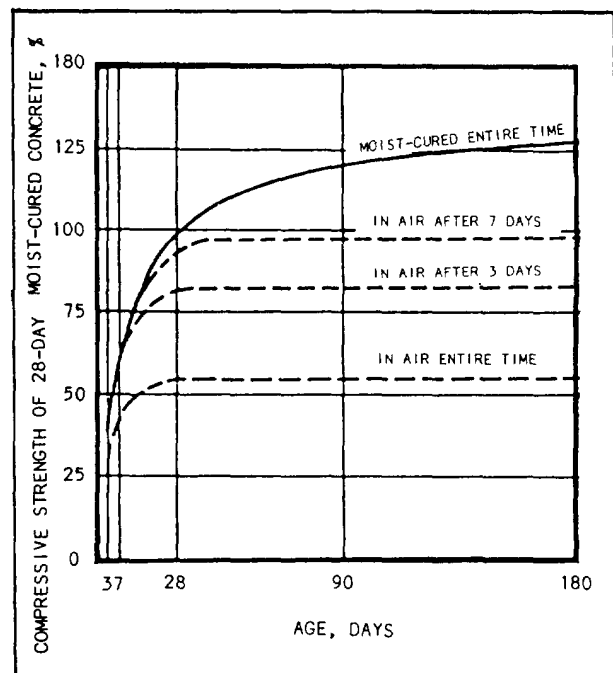

Figure 7-51.-Moist curing effect on compressive strength of concrete.

supply additional moisture and those that prevent moisture loss. Table 7-2 lists several of these methods and their advantages and disadvantages.

**METHODS THAT SUPPLY ADDITIONAL MOISTURE.**— Methods that supply additional moisture include sprinkling and wet covers. Both these methods add moisture to the concrete surface during the early hardening or curing period. They also provide some cooling through evaporation. This is especially important in hot weather.

Sprinkling continually with water is an excellent way to cure concrete. However, if you sprinkle at intervals, do not allow the concrete to dry out between

applications. The disadvantages of this method are the expense involved and volume of water required.

Wet covers, such as straw, earth, burlap, cotton mats, and other moisture-retaining fabrics, are used extensively in curing concrete. Figure 7-52 shows a typical application of wet burlap. Lay the wet coverings as soon as the concrete hardens enough to prevent surface damage. Leave them in place and keep them moist during the entire curing period.

If practical, horizontal placements can be flooded by creating an earthen dam around the edges and submerging the entire concrete structure in water.

Table 7-2.-Curing Methods

METHOD	ADVANTAGE	DISADVANTAGES
<b>Sprinkling with Water or Covering with Burlap</b>	Excellent results if kept constantly wet	Likelihood of drying between sprinklings; difficult on vertical walls
<b>Straw</b>	Insulator in winter	Can dry out, blow away, or burn
<b>Moist Earth</b>	Cheap but messy	Stains concrete; can dry out; removal problem
<b>Pending on Flat Surfaces</b>	Excellent results, maintains uniform temperature	Requires considerable labor; undesirable in freezing weather
<b>Curing Compounds</b>	Easy to apply and inexpensive	Sprayer needed; inadequate coverage allows drying out; film can be broken or tracked off before curing is completed; unless pigmented, can allow concrete to get too hot
<b>Waterproof Paper</b>	Excellent protection, prevents drying	Heavy cost can be excessive; must be kept in rolls; storage and handling problem
<b>Plastic Film</b>	Absolutely watertight, excellent protection. Light and easy to handle	Should be pigmented for heat protection; requires reasonable care and tears must be patched; must be weighed down to prevent blowing away

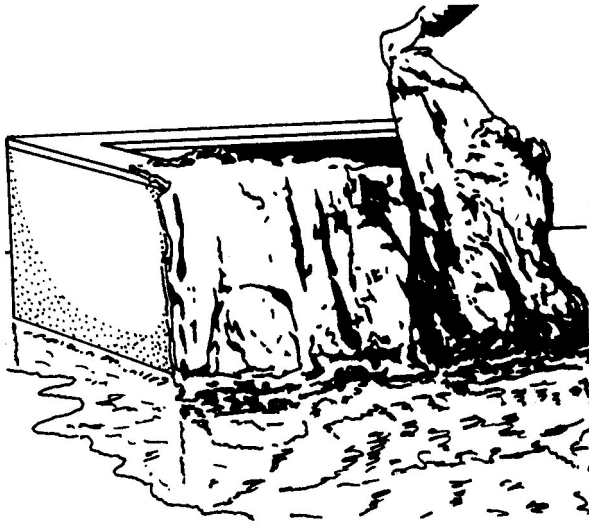

**Figure 7-52.-Curing a wall with wet burlap sacks.**

**METHODS THAT PREVENT MOISTURE LOSS.**— Methods that prevent moisture loss include laying waterproof paper, plastic film, or liquid-membrane-forming compounds, and simply leaving forms in place. All prevent moisture loss by sealing the surface.

Waterproof paper (figure 7-53) can be used to cure horizontal surfaces and structural concrete having relatively simple shapes. The paper should be large enough to cover both the surfaces and the edges of the concrete. Wet the surface with a fine water spray before covering. Lap adjacent sheets 12 inches

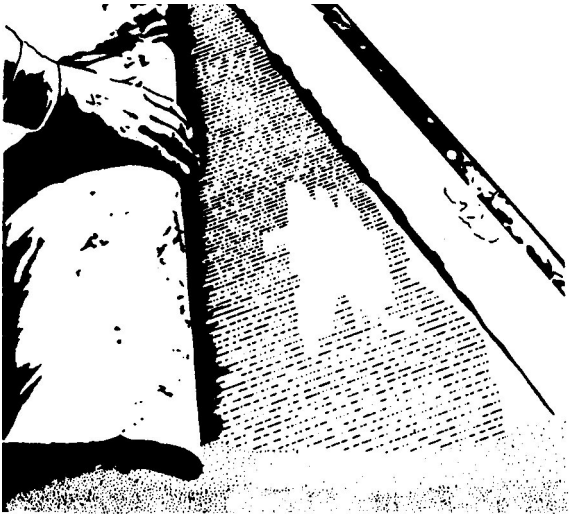

**Figure 7-53.-Waterproof paper used for curing.**

or more and weigh their edges down to form a continuous cover with closed joints. Leave the coverings in place during the entire curing period.

Plastic film materials are sometimes used to cure concrete. They provide lightweight, effective moisture barriers that are easy to apply to either simple or complex shapes. However, some thin plastic sheets may discolor hardened concrete, especially if the surface was steel-troweled to a hard finish. The coverage, overlap, weighing down of edges, and surface wetting requirements of plastic film are similar to those of waterproof paper.

Curing compounds are suitable not only for curing fresh concrete, but to further cure concrete following form removal or initial moist curing. You can apply them with spray equipment, such as hand-operated pressure sprayers, to odd slab widths or shapes of fresh concrete, and to exposed concrete surfaces following form removal. If there is heavy rain within 3 hours of application, you must respray the surface. You can use brushes to apply curing compound to formed surfaces, but do not use brushes on unformed concrete because of the risk of marring the surface, opening the surface to too much compound penetration, and breaking the surface film continuity. These compounds permit curing to continue for long periods while the concrete is in use. Because curing compounds can prevent a bond from forming between hardened and fresh concrete, do not use them if a bond is necessary.

Forms provide adequate protection against moisture loss if you keep the exposed concrete surfaces wet. Keep wood forms moist by sprinkling, especially during hot, dry weather.

### **FORM REMOVAL**

Forms should, whenever possible, be left in place for the entire curing period. Since early form removal is desirable for their reuse, a reliable basis for determining the earliest possible stripping time is necessary. Some of the early signs to look for during stripping are no excessive deflection or distortion and no evidence of cracking or other damage to the concrete due to the removal of the forms or the form supports. In any event, forms must not be stripped until the concrete has hardened enough to hold its own weight and any other weight it may be carrying. The surface must be hard enough to remain undamaged and unmarked when reasonable care is used in stripping the forms.

## Curing Period

Haunch boards (side forms on girders and beams) and wall forms can usually be removed after 1 day. Column forms usually require 3 days before the forms can be removed. Removal of forms for soffits on girders and beams can usually be done after 7 days. Floor slab forms (over 20-foot clear span between supports) usually require 10 days before removing the forms.

## Inspections

After removing the forms, the concrete should be inspected for surface defects. These defects may be rock pockets, inferior quality ridges at form joints, bulges, bolt holes, and form-stripping damage. Experience has proved that no steps can be omitted or carelessly performed without harming the serviceability of the work. If not properly performed, the repaired area may later become loose, crack at the edges, and not be watertight. Repairs are not always necessary, but when they are, they should be done immediately after stripping the forms (within 24 hours).

Defects can be repaired in various ways. Therefore, let's look at some common defects you may encounter when inspecting new concrete and how repairs can be made.

**RIDGES AND BULGES.**— Ridges and bulges can be repaired by careful chipping followed by rubbing with a grinding stone.

**HONEYCOMB.**— Defective areas, such as honeycomb, must be chipped out of the solid concrete. The edges must be cut as straight as possible at right angles to the surface or slightly undercut to provide a key at the edge of the patch. If a shallow layer of mortar is placed on top of the honeycomb concrete, moisture will form in the voids and subsequent weathering will cause the mortar to span off. Shallow patches can be filled with mortar placed in layers not more than 1/2-inch thick. Each layer is given a scratch finish to match the surrounding concrete by floating, rubbing, or tooling or on formed surfaces by pressing the form material against the patch while the mortar is still in place.

Large or deep patches can be filled with concrete held in place by forms. These patches should be reinforced and doweled to the hardened concrete (figure 7-54). Patches usually appear darker than the surrounding concrete. Some white cement should be

used in the mortar or concrete used for patching if appearance is important. A trial mix should be tried to determine the proportion of white and gray cements to use. Before mortar or concrete is placed in patches, the surrounding concrete should be kept wet for several hours. A grout of cement and water mixed to the consistency of paint should then be brushed into the surfaces to which the new material is to be bonded. Curing should be started as soon as possible to avoid early drying. Damp burlap, tarpaulins, and membrane-curing compounds are useful for this purpose.

**BOLT HOLES.**— Bolt holes should be filled with small amounts of grout carefully packed into place. The grout should be mixed as dry as possible, with just enough water so it compacts tightly when forced into place. Tie-rod holes extending through the concrete can be filled with grout with a pressure gun similar to an automatic grease gun.

**ROCK POCKETS.**— Rock pockets should be completely chipped out. The chipped out hole should have sharp edges and be so shaped that the grout patch will be keyed in place (figure 7-55). The surface of all holes that are to be patched should be kept moist for several hours before applying the grout. Grout should be placed in these holes in layers not over 1/4 inch thick and be well compacted. The grout should be allowed to set as long as possible before being used to reduce the amount of shrinkage and to make a better patch. Each layer should be scratched rough to improve the bond with the succeeding layer and the last layer smoothed to match the adjacent surface.

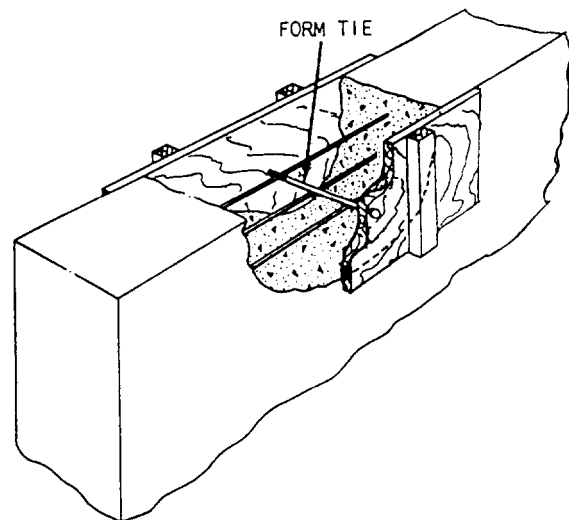

Figure 7-54.-Repair of large volumes of concrete.

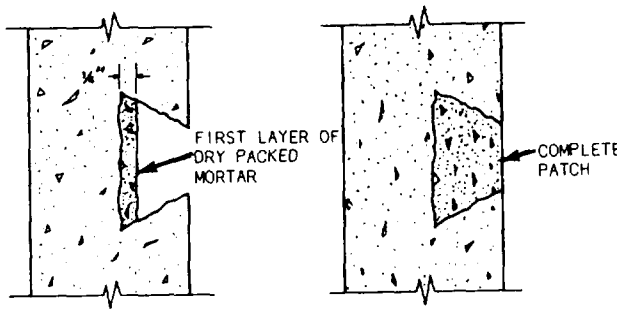

Figure 7-55.-Repairing concrete with dry-packed mortar.

Where absorptive form lining has been used, the patch can be made to match the rest of the surface by pressing a piece of form lining against the fresh patch.

View A of figure 7-56 shows an incorrectly installed patch. Feathered edges around a patch lack sufficient strength and will eventually break down. View B of the figure shows a correctly installed patch. The chipped area should be at least 1-inch deep with the edges at right angles to the surface. The correct method of screeding a patch is shown in view C. The new concrete should project slightly above the surface of the old concrete. It should be allowed to stiffen and then troweled and finished to match the adjoining surfaces.

### RECOMMENDED READING LIST

#### NOTE

Although the following references were current when this TRAMAN was published,

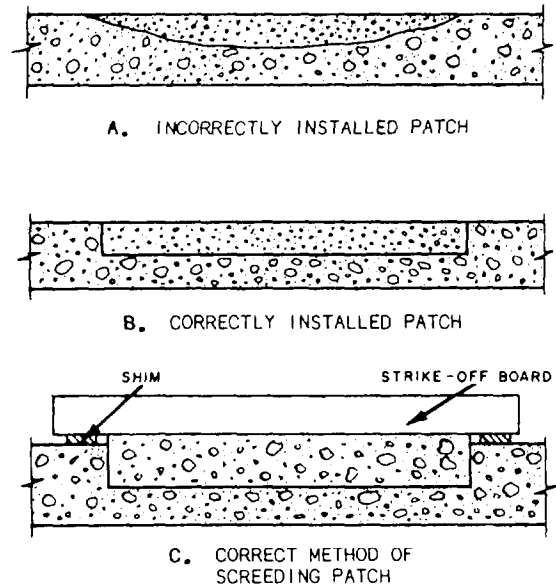

Figure 7-56.-Patching concrete.

their continued currency cannot be assured. You therefore need to ensure that you are studying the latest version.

*Concrete and Masonry*, FM 5-742, Headquarters, Department of the Army, Washington, D.C., 1985.

*Concrete Formwork*, Keel, Leonard, American Technical Publishers, Homewood, Ill., 1988.

*Steelworker 3 & 2*, NAVEDTRA 10653-G, Naval Education and Training Program Management Support Activity, Pensacola, Fla., 1988.



## CHAPTER 8

# MASONRY

Originally, masonry was the art of building a structure from stone. Today, it refers to construction consisting of units held together with mortar, such as concrete block, stone, brick, clay tile products, and, sometimes, glass block. The characteristics of masonry work are determined by the properties of the masonry units and mortar and by the methods of bonding, reinforcing, anchoring, tying, and joining the units into a structure.

### MASONRY TOOLS AND EQUIPMENT

*LEARNING OBJECTIVE: Upon completing this section, you should be able to identify the basic masonry tools and equipment.*

Masonry involves the use of a wide selection of tools and equipment. A set of basic mason's tools, including trowels, a chisel, hammer, and a jointer, is shown in figure 8-1.

### TROWELS

A trowel (figure 8-1) is used to pick up mortar from the board, throw mortar on the unit, spread the

mortar, and tap the unit down into the bed. A common trowel is usually triangular, ranging in size up to about 11 inches long and from 4 to 8 inches wide. Generally, short, wide trowels are best because they do not put too much strain on the wrist. Trowels used to point and strike joints are smaller, ranging from 3 to 6 inches long and 2 to 3 inches wide. We will talk more about pointing and striking joints later in the chapter.

### CHISEL

A chisel (figure 8-1) is used to cut masonry units into parts. A typical chisel is 2 1/2 to 4 1/2 inches wide.

### HAMMER

A mason's hammer (figure 8-1) has a square face on one end and a long chisel on the other. The hammer weighs from 1 1/2 to 3 1/2 pounds. You use it to split and rough-break masonry units.

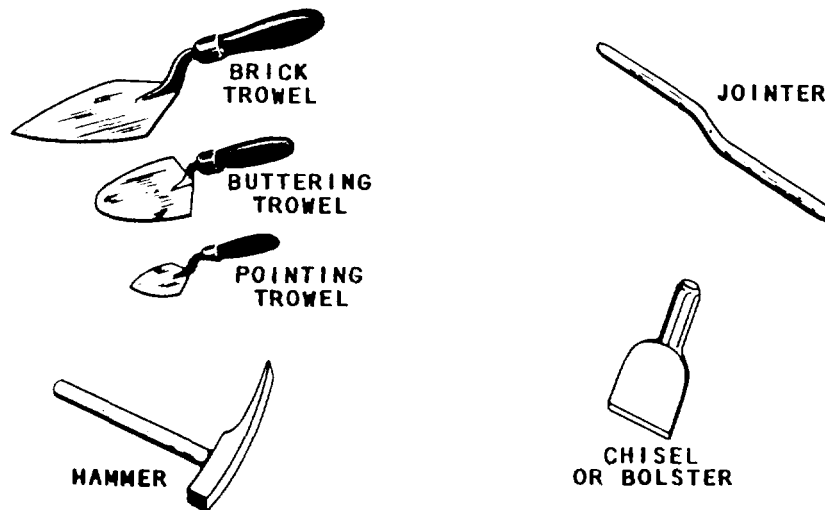

Figure 8-1.-Basic mason's tools.

## JOINTER

As its name implies, you use a jointer (figure 8- 1) to make various mortar joints. There are several different types of jointer—rounded, flat, or pointed—depending on the shape of the mortar joint you want.

## SQUARE

You use the square (figure 8-2, view 1) to measure right angles and to lay out corners. Squares are usually made of metal and come in various sizes.

## MASON'S LEVEL

The mason's level (figure 8-2, view 2) is used to establish "plumb" and "level" lines. A plumb line is absolutely vertical. A level line is absolutely horizontal. The level may be constructed of seasoned hardwood, various metals, or a combination of both. They are made as lightweight as possible without sacrificing strength to withstand fairly rough treatment. Levels may be equipped with single or double vials. Double-vial levels are preferred since they can be used either horizontally or vertically.

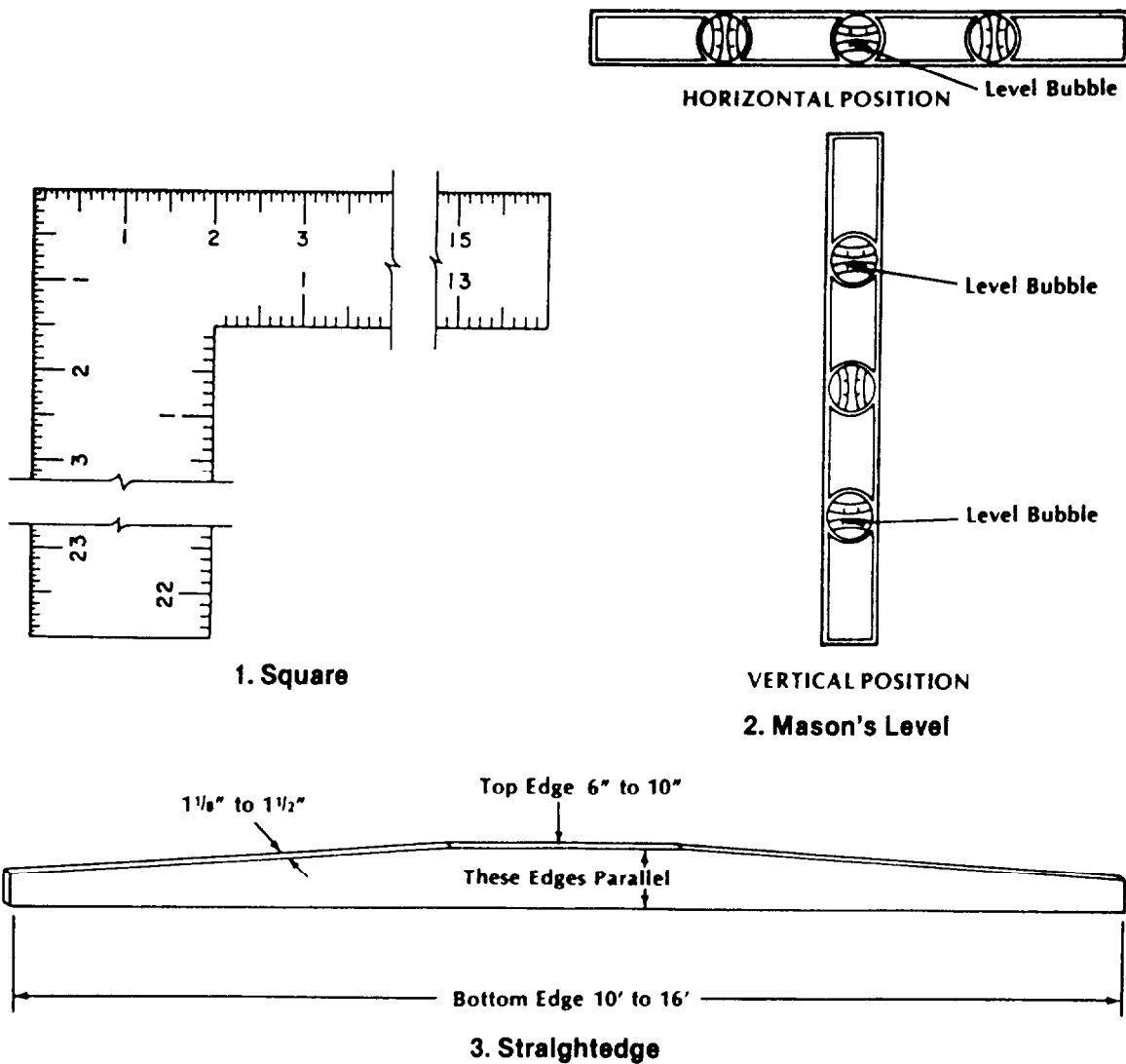

Figure 8-2.-Square, mason's level, and straightedge.



Levels are shaped similar to rulers and have vials enclosed in glass. Inside each vial is a bubble of air suspended in either alcohol or oil. When a bubble is located exactly between the two center marks on the vial, the object is either level or plumb, depending on the position in which the mason is using the level. In a level, alcohol is the more suitable since oil is more affected by heat and cold. The term “spirit level” indicates that alcohol is used in the vials. The vials are usually embedded in plaster or plastic so that they remain secure and true. Shorter levels are made for jobs where a longer level will not fit. The most popular of these are 24 and 18 inches long.

In a level constructed of wood, you should occasionally rub a small amount of linseed oil into the wood with a clean cloth. This treatment also stops mortar from sticking to the level. Do not use motor oil as this eventually rots the wood.

### **STRAIGHTEDGE**

A straightedge (figure 8-2, view 3) can be any length up to 16 feet. Thickness can be from 1 1/8 inches to 1 1/2 inches, and the middle portion of the top edge from 6 to 10 inches wide. The middle portion of the top edge must be parallel to the bottom edge. You use a straightedge to extend a level to plumb or level distances longer than the level length.

### **MISCELLANEOUS ITEMS**

Other mason’s tools and equipment include shovels, mortar hoes, wheelbarrows, chalk lines, plumb bobs, and a 200-foot ball of good-quality mason’s line. Be sure to keep wheelbarrows and mortar tools clean; hardened mortar is difficult to remove. Clean all tools and equipment thoroughly at the end of each day or when the job is finished.

A mortar mixing machine (figure 8-3) is used for mixing large quantities of mortar. The mixer consists primarily of a metal drum containing mixing blades mounted on a chassis equipped with wheels for towing the machine from one job site to another. The mixer is powered by either an electric motor or a gasoline engine. After mixing, the mortar is discharged into a mortar box or wheelbarrow, usually by tilting the mixer drum. As with any machine, refer to the manufacturer’s operator and maintenance

manuals for proper operation. Be sure to follow safety requirements related to mixer operations.

## **CONCRETE MASONRY**

*LEARNING OBJECTIVE: Upon completing this section, you should be able to identify the components and requirements of concrete masonry construction.*

One of the most common masonry units is the concrete block. It consists of hardened cement and may be completely solid or contain single or multiple hollows. It is made from conventional cement mixes and various types of aggregate. These include sand, gravel, crushed stone, air-cooled slag, coal cinders, expanded shale or clay, expanded slag, volcanic cinders (pozzolan), pumice, and “scoria” (refuse obtained from metal ore reduction and smelting). The term “concrete block” was formerly limited to only hollow masonry units made with such aggregates as sand, gravel, and crushed stone. Today, the term covers all types of concrete block—both hollow and solid—made with any kind of aggregate. Concrete blocks are also available with applied glazed surfaces, various pierced designs, and a wide variety of surface textures.

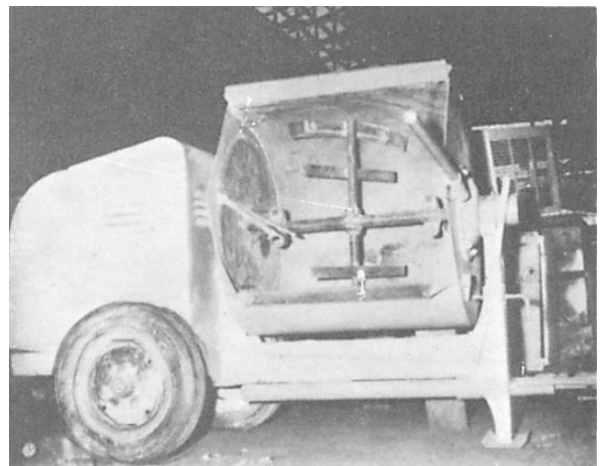

**Figure 8-3.-Mortar mixing machine**

Although concrete block is made in many sizes and shapes (figure 8-4) and in both modular and nonmodular dimensions, its most common unit size is 7 5/8 by 7 5/8 by 15 5/8 inches. This size is known as 8-by-8-by-16-inch block nominal size. All concrete block must meet certain specifications covering size, type, weight, moisture content, compressive strength, and other characteristics. Properly designed and constructed, concrete masonry walls satisfy many building requirements, including fire prevention,

safety, durability, economy, appearance, utility, comfort, and acoustics.

Concrete blocks are used in all types of masonry construction. The following are just a few of many examples:

- Exterior load-bearing walls (both below and above grade);
- Interior load-bearing walls;

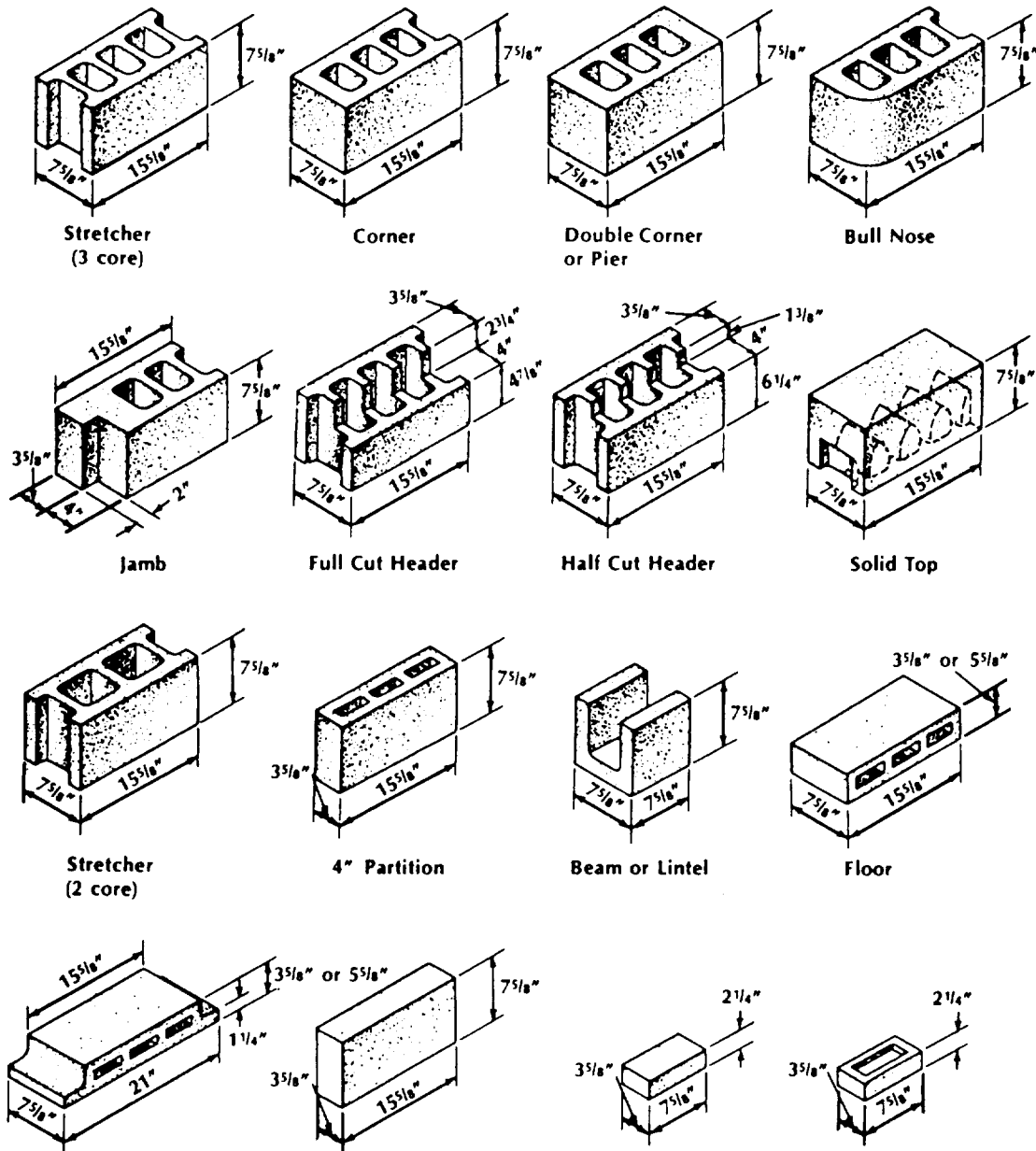

Figure 8-4. Typical unit sizes and shapes of concrete masonry units.

- Fire walls and curtain walls;
- Partitions and panel walls;
- Backing for brick, stone, and other facings;
- Fireproofing over structural members;
- Fire safe walls around stairwells, elevators, and enclosures;
- Piers and columns;
- Retaining walls;
- Chimneys; and
- Concrete floor units.

There are five main types of concrete masonry units:

1. Hollow load-bearing concrete block;
2. Solid load-bearing concrete block;
3. Hollow nonload-bearing concrete block;
4. Concrete building tile; and
5. Concrete brick.

Load-bearing blocks are available in two grades: N and S. Grade N is for general use, such as exterior walls both above and below grade that may or may not be exposed to moisture penetration or weather. Both grades are also used for backup and interior walls. Grade S is for above-grade exterior walls with a weather-protective coating and for interior walls. The grades are further subdivided into two types. Type I consists of moisture-controlled units for use in arid climates. Type II consists of nonmoisture-controlled units.

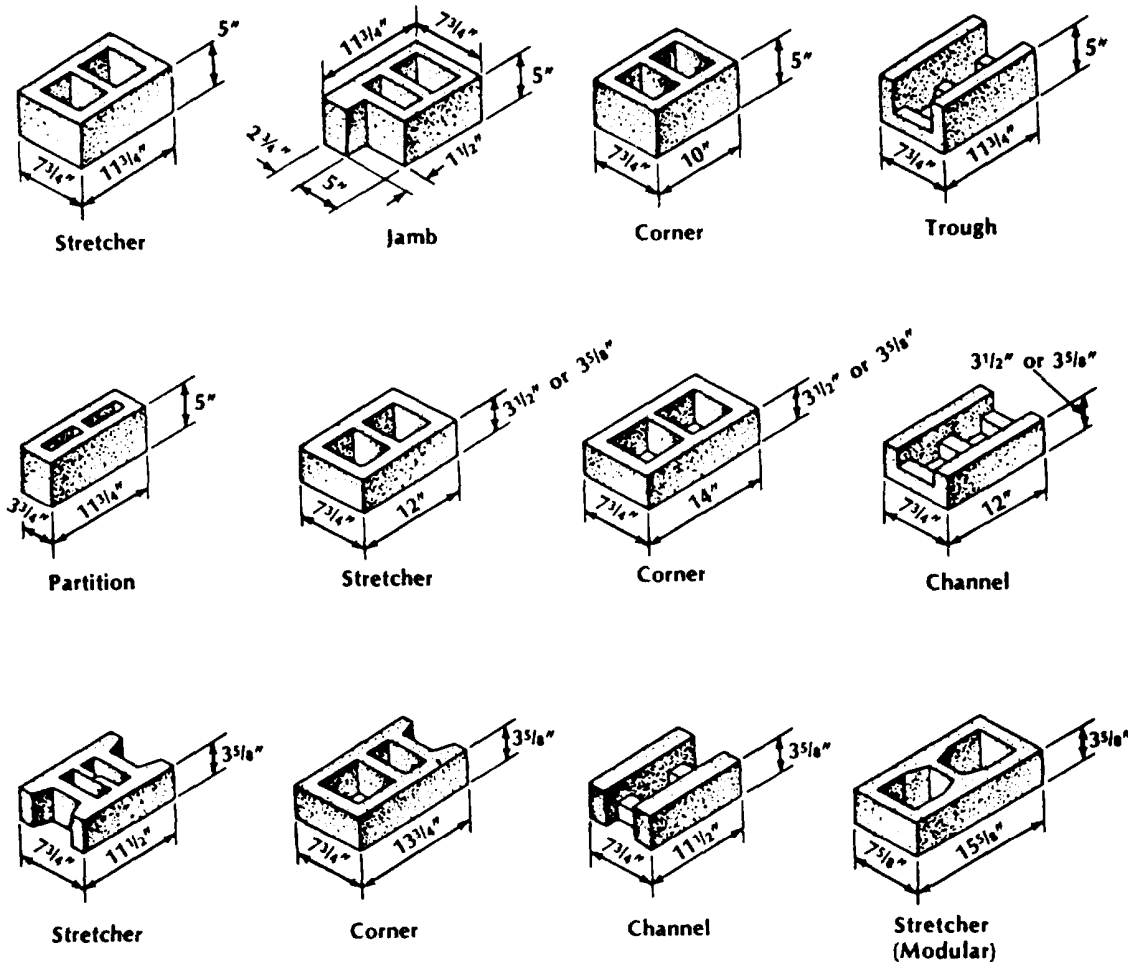

NOTE: Dimensions are actual unit sizes. A  $7\frac{5}{8}'' \times 7\frac{5}{8}'' \times 15\frac{5}{8}''$  unit is an  $8'' \times 8'' \times 16''$  nominal size block.

Figure 8-4. Typical unit sizes and shapes of concrete masonry units—Continued.

## BLOCK SIZES AND SHAPES

Concrete masonry units are available in many sizes and shapes to fit different construction needs. Both full- and half-length sizes are shown in figure 8-4. Because concrete block sizes usually refer to nominal dimensions, a unit actually measuring 7 5/8-by-7 5/8-by-15 5/8-inches is called an 8-by-8-by-16-inch block. When laid with 3/8-inch mortar joints, the unit should occupy a space exactly 8-by-8-by-16 inches.

ASTM (American Society for Testing and Materials) specifications define a solid concrete block as having a core area not more than 25 percent of the gross cross-sectional area. Most concrete bricks are solid and sometimes have a recessed surface like the frogged brick shown in figure 8-4. In contrast, a hollow concrete block has a core area greater than 25 percent of its gross cross-sectional area—generally 40 percent to 50 percent.

Blocks are considered heavyweight or lightweight, depending on the aggregate used in their production. A hollow load-bearing concrete block 8-by-8-by-16-inches nominal size weighs from 40 to 50 pounds when made with heavyweight aggregate, such as sand, gravel, crushed stone, or air-cooled slag. The same size block weighs only 25 to 35 pounds when made with coal cinders, expanded shale, clay, slag, volcanic cinders, or pumice. The choice of blocks depends on both the availability and requirements of the intended structure.

Blocks may be cut with a chisel. However, it is more convenient and accurate to use a power-driven masonry saw (figure 8-5). Be sure to follow the manufacturer's manual for operation and maintenance. As with all electrically powered equipment, follow all safety guidelines.

## BLOCK MORTAR JOINTS

The sides and the recessed ends of a concrete block are called the shell. The material that forms the partitions between the cores is called the web. Each of the long sides of a block is called a face shell. Each of the recessed ends is called an end shell. The vertical ends of the face shells, on either side of the end shells, are called the edges.

Bed joints on first courses and bed joints in column construction are mortared by spreading a 1-inch layer of mortar. This procedure is referred to as "full mortar bedding." For most other bed joints, only the upper edges of the face shells need to be mortared. This is referred to as "face shell mortar bedding."

Head joints may be mortared by buttering both edges of the block being laid or by buttering one edge on the block being laid and the opposite edge on the block already in place.

## MASONRY MORTAR

Properly mixed and applied mortar is necessary for good workmanship and good masonry service because it must bond the masonry units into a strong, well-knit structure. The mortar that bonds concrete block, brick, or clay tile will be the weakest part of the masonry unless you mix and apply it properly. When masonry leaks, it is usually through the joints. Both the strength of masonry and its resistance to rain penetration depend largely on the strength of the bond between the masonry unit and the mortar. Various factors affect bond strength, including the type and quantity of the mortar, its plasticity and workability, its water retentivity, the surface texture of the mortar bed, and the quality of workmanship in laying the units. You can correct irregular brick dimensions and shape with a good mortar joint.

### Workability of Mortar

Mortar must be plastic enough to work with a trowel. You obtain good plasticity and workability by

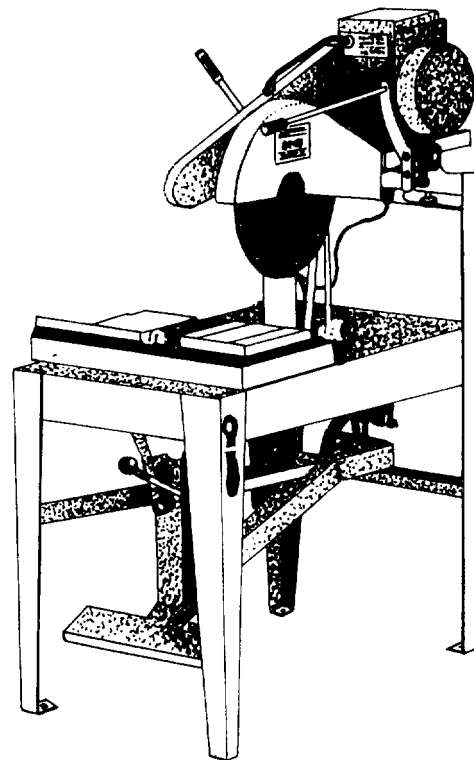

Figure 8-5.-Masonry saw.

using mortar having good water retentivity, using the proper grade of sand, and thorough mixing. You do not obtain good plasticity by using a lot of cementitious materials. Mortar properties depend largely upon the type of sand it contains. Clean, sharp sand produces excellent mortar, but too much sand causes mortar to segregate, drop off the trowel, and weather poorly.

### Water Retentivity

Water retentivity is the mortar property that resists rapid loss of water to highly absorbent masonry units. Mortar must have water to develop the bond. If it does not contain enough water, the mortar will have poor plasticity and workability, and the bond will be weak and spotty. Sometimes, you must wet brick to control water absorption before applying mortar, but never wet concrete masonry units.

### Mortar Strength and Durability

The type of service that the masonry must give determines the strength and durability requirements of mortar. For example, walls subject to severe stress or weathering must be laid with more durable,

stronger mortar than walls for ordinary service. Table 8-1 gives mortar mix proportions that provide adequate mortar strength and durability for the conditions listed.

### Types of Mortar

The following mortar types are proportioned on a volume basis:

- **Type M**— One part portland cement, one-fourth part hydrated lime or lime putty, and three parts sand; or, one part portland cement, one part type II masonry cement, and six parts sand. Type M mortar is suitable for general use, but is recommended specifically for below-grade masonry that contacts earth, such as foundations, retaining walls, and walks.
- **Type S**— One part portland cement, one-half part hydrated lime or lime putty, and four and one-half parts sand; or, one-half part portland cement, one part type II masonry cement, and four and one-half parts sand. Type S mortar is also suitable for general use, but is recommended where high resistance to lateral forces is required.

Table 8-1.-Recommended Mortar Mix Proportions by Unit Volume

TYPE OF SERVICE	CEMENT	HYDRATED LIME	MORTAR SAND IN DAMP, LOOSE CONDITION
ORDINARY	1 unit masonry cement <sup>1</sup>	1/2 to 1 1/4 units	2 1/4 to 3 units
	or 1 unit portland cement		4 1/2 to 6 units
ISOLATED PIERS SUBJECT TO EXTREMELY HEAVY LOADS, VIOLENT WINDS, EARTHQUAKES, OR SEVERE FROST ACTION	1 unit masonry cement <sup>1</sup> plus 1 unit portland cement	0 to 1/4 unit	4 1/2 to 6 units
	or 1 unit portland cement		2 1/4 to 3 units

<sup>1</sup>ASTM Specification C91 Type II

- **Type N**— One part portland cement, one part hydrated lime or lime putty, and six parts sand; or, one part type II masonry cement and three parts sand. Type N mortar is suitable for general use in above-grade exposed masonry where high compressive or lateral strength is not required.
- **Type O**— One part portland cement, two parts hydrated lime or lime putty, and nine parts sand; or, one part type I or type II masonry cement and three parts sand. Type O mortar is recommended for load-bearing, solid-unit walls when the compressive stresses do not exceed 100 pounds per square inch (psi) and the masonry is not subject to freezing and thawing in the presence of a lot of moisture.

## MIXING MORTAR

The manner in which mortar is mixed has a lot to do with the quality of the final product. In addition to machine and hand mixing, you need to know the requirements for introducing various additives, including water, to the mix in order to achieve optimum results.

### Machine Mixing

Machine mixing refers to mixing large quantities of mortar in a drum-type mixer. Place all dry ingredients in the mixer first and mix them for 1 minute before adding the water. When adding water, you should always add it slowly. Minimum mixing time is 3 minutes. The mortar should be mixed until a completely uniform mixture is obtained.

### Hand Mixing

Hand mixing involves mixing small amounts of mortar by hand in a mortar box or wheelbarrow. Take care to mix all ingredients thoroughly to obtain a uniform mixture. As in machine mixing, mix all dry materials together first before adding water. Keep a steel drum of water close at hand to use as the water supply. You should also keep all your masonry tools free of hardened mortar mix and dirt by immersing them in water when not in use.

### Requirements

You occasionally need to mix lime putty with mortar. When machine mixing, use a pail to measure the lime putty. Place the putty on top of the sand. When hand mixing, add the sand to the lime putty.

Wet pails before filling them with mortar and clean them immediately after emptying.

Mixing water for mortar must meet the same quality requirements as mixing water for concrete. Do not use water containing large amounts of dissolved salts. Salts weaken the mortars.

You can restore the workability of any mortar that stiffens on the mortar board due to evaporation by remixing it thoroughly. Add water as necessary, but discard any mortar stiffened by initial setting. Because it is difficult to determine the cause of stiffening, a practical guide is to use mortar within 2 1/2 hours after the original mixing. Discard any mortar you do not use within this time.

Do not use an antifreeze admixture to lower the freezing point of mortars during winter construction. The quantity necessary to lower the freezing point to any appreciable degree is so large it will seriously impair the strength and other desirable properties of the mortar.

Do not add more than 2-percent calcium chloride (an accelerator) by weight of cement to mortar to accelerate its hardening rate and increase its early strength. Do not add more than 1-percent calcium chloride to masonry cements. Make a trial mix to find the percentage of calcium chloride that gives the desired hardening rate. Calcium chloride should not be used for steel-reinforced masonry. You can also obtain high early strength in mortars with high-early-strength portland cement.

## MODULAR PLANNING

Concrete masonry walls should be laid out to make maximum use of full- and half-length units. This minimizes cutting and fitting of units on the job. Length and height of walls, width and height of openings, and wall areas between doors, windows, and corners should be planned to use full-size and half-size units, which are usually available (figure 8-6). This procedure assumes that window and door frames are of modular dimensions which fit modular full- and half-size units. Then, all horizontal dimensions should be in multiples of nominal full-length masonry units.

Both horizontal and vertical dimensions should be designed to be in multiples of 8 inches. Table 8-2 lists nominal length of concrete masonry walls by stretchers. Table 8-3 lists nominal height of concrete masonry walls by courses. When 8-by-4-by-16 units are used, the horizontal dimensions should be planned in multiples of 8 inches (half-length units) and the vertical dimensions in multiples of 4 inches. If the thickness of the wall is greater or less than the length of a half unit, a special-length unit is required at each

corner in each course. Table 8-4 lists the average number of concrete masonry units by size and approximate number of cubic feet of mortar required for every 100 square feet of concrete masonry wall. Table 8-5 lists the number of 16-inch blocks per course for any wall.

You should always use outside measurements when calculating the number of blocks required per course. For example, a basement 22 feet by 32 feet should require 79 blocks for one complete course. Multiply 79 by the number of courses needed. Thus, a one-course basement requires a total of 790 blocks for a solid wall, from which deductions should be made for windows and doors. If any dimension is an odd number, use the nearest smaller size listed in the table. For example, for a 22-foot by 31-foot enclosure, use 22 feet by 30 feet and add one-half block per row.

As a Builder, you might find yourself in the field without the tables handy, so here is another method. Use  $\frac{3}{4}$  times the length and  $\frac{3}{2}$  times the height for figuring how many 8-by-8-by-16-inch blocks you need for a wall. Let's take an example:

Given: A wall 20 ft long x 8 ft high

$$\frac{3}{4} \times 20 = 60 + 4 = 15 \text{ (8" } \times \text{ 8" } \times \text{ 16" block per course)}$$

$$\frac{3}{2} \times 8 = 24 + 2 = 12 \text{ courses high}$$

$$15 \times 12 = 180 \text{ total blocks}$$

## ESTIMATING MORTAR

You can use "rule 38" for calculating the raw material needed to mix 1 yard of mortar without a great deal of paperwork. This rule does not, however, accurately calculate the required raw materials for large masonry construction jobs. For larger jobs, use the absolute volume or weight formula. In most cases, though, and particularly in advanced base construction, you can use rule 38 to quickly estimate the quantities of the required raw materials.

Builders have found that it takes about 38 cubic feet of raw materials to make 1 cubic yard of mortar. In using rule 38 for calculating mortar, take the rule number and divide it by the sum of the quantity figures specified in the mix. For example, let's assume that the building specifications call for a 1:3 mix for mortar,  $1 + 3 = 4$ . Since  $38 \div 4 = 9 \frac{1}{2}$ , you'll need  $9 \frac{1}{2}$  sacks, or  $9 \frac{1}{2}$  cubic feet, of cement. To calculate the amount of fine aggregate (sand), you multiply  $9 \frac{1}{2}$  by 3. The product ( $28 \frac{1}{2}$  cubic feet) is the amount of sand you need to mix 1 cubic yard of mortar using a 1:3 mix. The sum of the two required quantities should always equal 38. This is how you can check whether you are using the correct amounts. In the above example,  $9 \frac{1}{2}$  sacks of cement plus  $28 \frac{1}{2}$  cubic feet of sand equal 38.

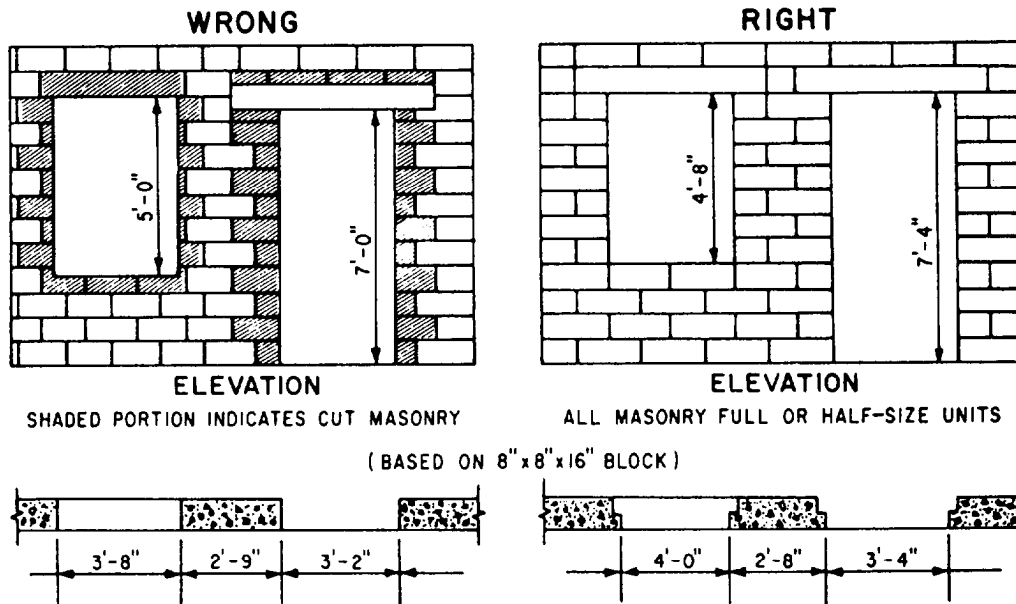

Figure 8-6.-Planning concrete masonry wall openings.

Table 8-2.-Nominal Lengths of Concrete Masonry Walls in Stretchers

NUMBER OF STRETCHERS	NOMINAL LENGTH OF CONCRETE MASONRY WALLS	
	Units 15 5/8" long and half units 7 5/8" long with 3/8" thick head joints	Units 11 5/8" long and half units 5 5/8" long with 3/8" thick head joints
1	1'4"	1'0"
1 1/2	2'0"	1'6"
2	2'	2'0"
2 1/2	3'4"	2'6"
3	4'0"	3'0"
3 1/2	4'8"	3'6"
4	5'4"	4'0"
4 1/2	6'0"	4'6"
5	6'8"	5'0"
5 1/2	7'4"	5'6"
6	8'0"	6'0"
6 1/2	8'8"	6'6"
7	9'4"	7'0"
7 1/2	10'0"	7'6"
8	10'8"	8'0"
8 1/2	11'4"	8'6"
9	12'0"	9'0"
9 1/2	12'8"	9'6"
10	13'4"	10'0"
10 1/2	14'0"	10'6"
11	14'8"	11'0"
11 1/2	15'4"	11'6"
12	16'0"	12'0"
12 1/2	16'8"	12'6"
13	17'4"	13'0"
13 1/2	18'0"	13'6"
14	19'4"	14'0"
14 1/2	20'0"	14'6"
15	20'0"	15'0"
20	26'8"	20'0"

**NOTE:** Actual wall length is measured from outside edge to outside edge of units, and equals the nominal length minus 3/8" (one mortar joint).



Table 8-3.-Nominal Heights of Modular Concrete Masonry Walls in Courses

NUMBER OF COURSES	NOMINAL HEIGHT OF CONCRETE MASONRY WALLS	
	Units 7 5/8" high and 3/8" thick bed joints	Units 3 5/8" high and 3/8" thick bed joints
1	0'8"	0'4"
2	1'4"	0'8"
3	2'0"	1'0"
4	2'8"	1'4"
5	3'4"	1'8"
6	4'0"	2'0"
7	4'8"	2'4"
8	5'4"	2'8"
9	6'0"	3'0"
10	6'8"	3'4"
15	10'0"	5'0"
20	13'4"	6'8"
25	16'8"	8'4"
30	20'0"	10'0"
35	23'4"	11'8"
40	26'8"	13'4"
45	30'0"	15'0"
50	33'4"	16'8"

**NOTE:** For concrete masonry units 7 5/8" and 3 5/8" in height laid with 3/8" mortar joints. Height is measured from center to center of mortar joints.

Table 8-4.-Average Concrete Masonry Units and Mortar per 100 sq. ft. of Wall

DESCRIPTION, SIZE OF BLOCK (IN.)	THICKNESS WALL (IN.)	NUMBER OF UNITS PER 100 SQ. FT. OF WALL AREA	MORTAR (CU. FT.)
8 × 8 × 16	8	110	3.25
8 × 8 × 12	8	146	3.5
8 × 12 × 16	12	110	3.25
8 × 3 × 16	3	110	2.75
9 × 3 × 18	3	87	2.5
12 × 3 × 12	3	100	2.5
8 × 3 × 12	3	146	3.5
8 × 4 × 16	4	110	3.25
9 × 4 × 18	4	87	3.25
12 × 4 × 12	4	100	3.25
8 × 4 × 12	4	146	4
8 × 6 × 16	6	110	3.25

Table 8-5.-Number of 16-Inch Blocks per Course

LENGTH IN FEET	WIDTH IN FEET																	
	6	8	10	12	14	16	18	20	22	24	26	28	30	32	34	36	38	40
8	19	22	25	28	31	34	37	40	43	46	49	52	55	58	61	64	67	70
10	22	25	28	31	34	37	40	43	46	49	52	55	58	61	64	67	70	73
12	25	28	31	34	37	40	43	46	49	52	55	58	61	64	67	70	73	76
14	28	31	34	37	40	43	46	49	52	55	58	61	64	67	70	73	76	79
16	31	34	37	40	43	46	49	52	55	58	61	64	67	70	73	76	79	82
18	34	37	40	43	46	49	52	55	58	61	64	67	70	73	76	79	82	85
20	37	40	43	46	49	52	55	58	61	64	67	70	73	76	79	82	85	88
22	40	43	46	49	52	55	58	61	64	67	70	73	76	79	82	85	88	91
24	43	46	49	52	55	58	61	64	67	70	73	76	79	82	85	88	91	94
26	46	49	52	55	58	61	64	67	70	73	76	79	82	85	88	91	94	97
28	49	52	55	58	61	64	67	70	73	76	79	82	85	88	91	94	97	100
30	52	55	58	61	64	67	70	73	76	79	82	85	88	91	94	97	100	103
32	55	58	61	64	67	70	73	76	79	82	85	88	91	94	97	100	103	106
34	58	61	64	67	70	73	76	79	82	85	88	91	94	97	100	103	106	109
36	61	64	67	70	73	76	79	82	85	88	91	94	97	100	103	106	109	112
38	64	67	70	73	76	79	82	85	88	91	94	97	100	103	106	109	112	115
40	67	70	73	76	79	82	85	88	91	94	97	100	103	106	109	112	115	118
42	70	73	76	79	82	85	88	91	94	97	100	103	106	109	112	115	118	121
44	73	76	79	82	85	88	91	94	97	100	103	106	109	112	115	118	121	124
46	76	79	82	85	88	91	94	97	100	103	106	109	112	115	118	121	124	127
48	79	82	85	88	91	94	97	100	103	106	109	112	115	118	121	124	127	130
50	82	85	88	91	94	97	100	103	106	109	112	115	118	121	124	127	130	133
52	85	88	91	94	97	100	103	106	109	112	115	118	121	124	127	130	133	136
54	88	91	94	97	100	103	106	109	112	115	118	121	124	127	130	133	136	139
56	91	94	97	100	103	106	109	112	115	118	121	124	127	130	133	136	139	142
58	94	97	100	103	106	109	112	115	118	121	124	127	130	133	136	139	142	145
60	97	100	103	106	109	112	115	118	121	124	127	130	133	136	139	142	145	148

**SAFE HANDLING OF MATERIAL**

When you handle cement or lime bags, wear goggles and snug-fitting neckbands and wristbands. Always practice good personal cleanliness and never wear clothing that has become stiff with cement. Cement-impregnated clothing irritates the skin and may cause serious infection. Any susceptibility of the skin to cement and lime burns should be reported. Personnel who are allergic to cement or lime should be transferred to other jobs.

Bags of cement or lime should not be piled more than 10 bags high on a pallet. The only exception is when storage is in bins or enclosures built for such storage. The bags around the outside of the pallet should be placed with the mouths of the bags facing the center. The first five tiers of bags each way from any corner must be cross piled. A setback starting with the sixth tier should be made to prevent piled bags from falling outward. If you have to pile bags above 10 tiers, another setback must be made. The back tier, when not resting against an interior wall of

sufficient strength to withstand the pressure, should be set back one bag every five tiers, the same as the end tiers. During unpling, the entire top of the pile should be kept level and the necessary setbacks maintained.

Lime and cement must be stored in a dry place. This helps prevent lime from crumbling and the cement from hydrating before it is used.

**CONCRETE MASONRY  
CONSTRUCTION**

*LEARNING OBJECTIVE: Upon completing this section, you should be able to explain the elements of concrete masonry*

Good workmanship is a very important factor in building masonry walls. You should make every effort to lay each masonry unit plumb and true. In the following paragraphs, we will discuss the basic steps in laying up masonry walls.

## STEPS IN CONSTRUCTION

The first step in building a concrete masonry wall is to locate the corners of the structure. In locating the corners, you should also make sure the footing or slab formation is level so that each Builder starts each section wall on a common plane. This also helps ensure that the bed joints are straight when the

sections are connected. If the foundation is badly out of level, the entire first course should be laid before Builders begin working on other courses. If this is not possible, a level plane should be established with a transit or engineer's level.

The second step is to chase out bond, or lay out, by placing the first course of blocks without mortar (figure 8-7, view 1). Snap a chalk line to mark the

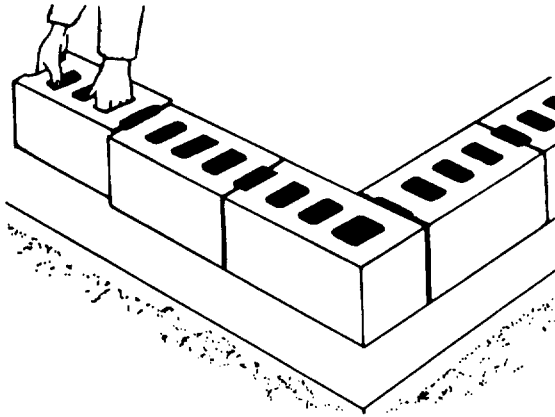

1. PLACING BLOCKS WITHOUT MORTAR  
(CHASING THE BOND)

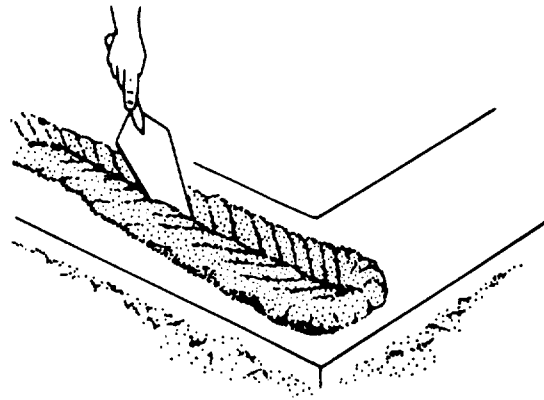

2. SPREADING AND FURROWING MORTAR BED

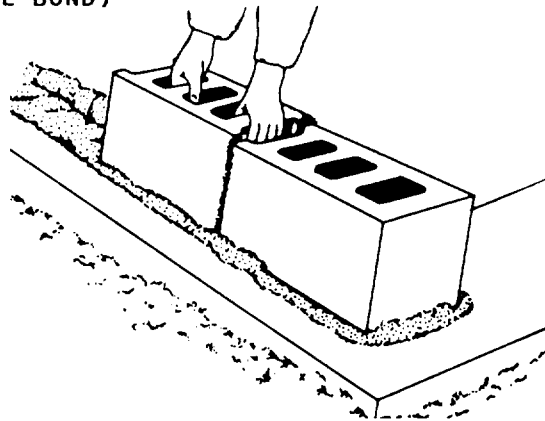

3. POSITIONING AND ALIGNING CORNER BLOCK

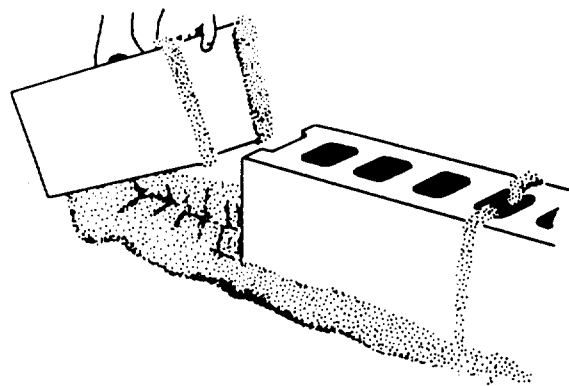
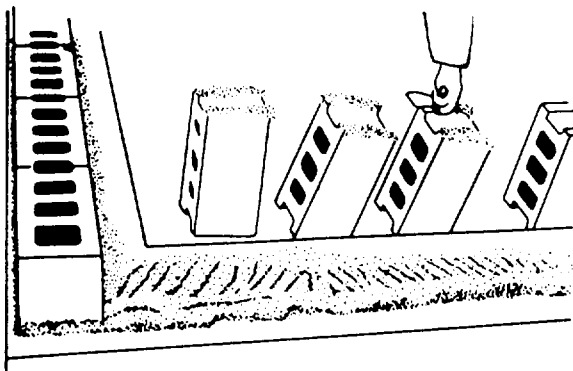
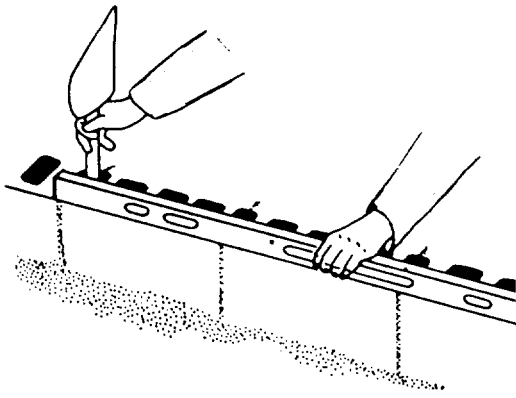
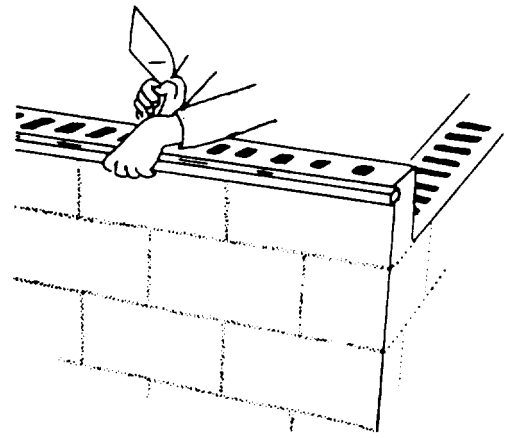

Figure 8-7.-Laying first course of blocks for a wall.



**1. Leveling Block**



**1. Aligning**

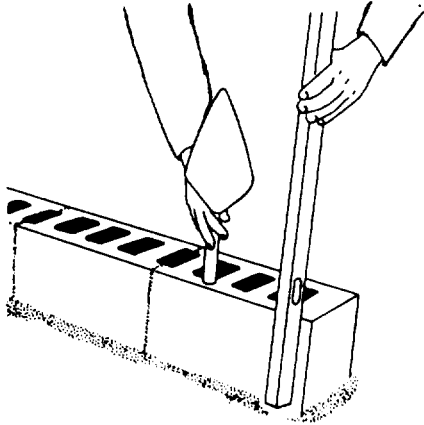

**2. Plumbing Block**

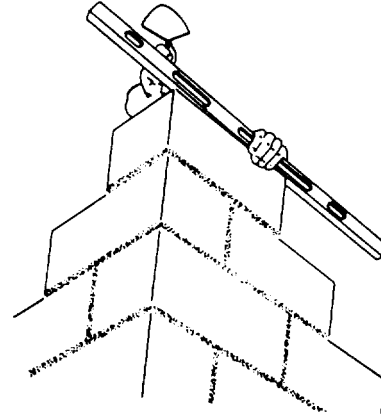

**2. Leveling**

**Figure 8-8.-Leveling and plumbing first course of blocks for a wall.**

footing and align the blocks accurately. Then, use a piece of material  $\frac{3}{8}$  inch thick to properly space the blocks. This helps you get an accurate measurement.

The third step is to replace the loose blocks with a full mortar bed, spreading and furrowing it with a

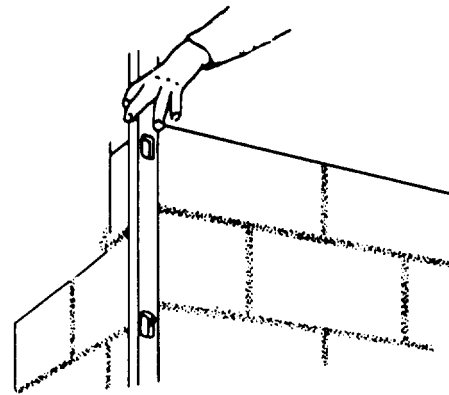

**3. Plumbing**

**Figure 8-10.-Checking each course at the corner.**

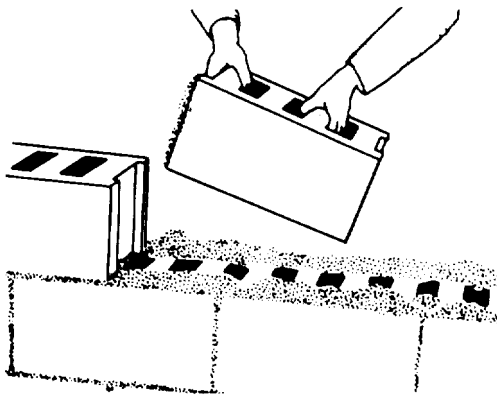

**Figure 8-9.-Vertical joints.**

trowel to ensure plenty of mortar under the bottom edges of the first course (figure 8-7, view 2). Carefully position and align the corner block first (view 3 of figure 8-7). Lay the remaining first-course blocks with the thicker end up to provide a larger mortar-bedding area. For the vertical joints, apply mortar only to the block ends by placing several blocks on end and buttering them all in one operation

(view 4). Make the joints  $\frac{3}{8}$  inch thick. Then, place each block in its final position, and push the block down vertically into the mortar bed and against the previously laid block. This ensures a well-tilled vertical mortar joint (view 5). After laying three or four blocks, use a mason's level as a straightedge to check correct block alignment (figure 8-8, view 1). Then, use the level to bring the blocks to proper grade and plumb by tapping with a trowel handle as shown in view 2. Always lay out the first course of concrete masonry carefully and make sure that you properly align, level, and plumb it. This assures that succeeding courses and the final wall are both straight and true.

The fourth step is to build up the corners of the wall, usually four or five courses high. This is also called laying up a lead. Step back each course one-half block. For the horizontal joints, apply mortar only to the tops of the blocks already laid. For the vertical joints, you can apply mortar either to the ends of the new block or the end of the block previously laid, or both, to ensure well-filled joints (figure 8-9). As you lay each course at the corner, check the course with a level for alignment (figure 8-10, view 1), for level (view 2), and for

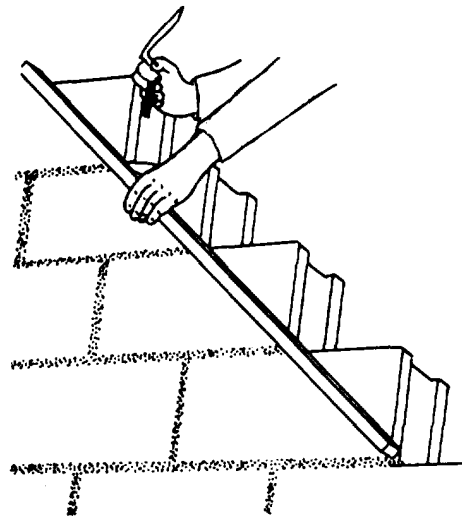

Figure 8-12.-Checking horizontal block spacing.

plumb (view 3). Carefully check each block with a level or straightedge to make sure that all the block faces are in the same plane. This ensures true, straight walls. A story or course pole, which is a board with markings 8 inches apart (figure 8-11), helps accurately place each masonry course. Also check the horizontal block spacing by placing a level diagonally across the corners of the blocks (figure 8-12).

When filling in the wall between the corners, first stretch a mason's line along the extensor block edges from corner to corner for each course. Then lay the top outside edge of each new block to this line (figure 8-13). How you grip a block before laying is

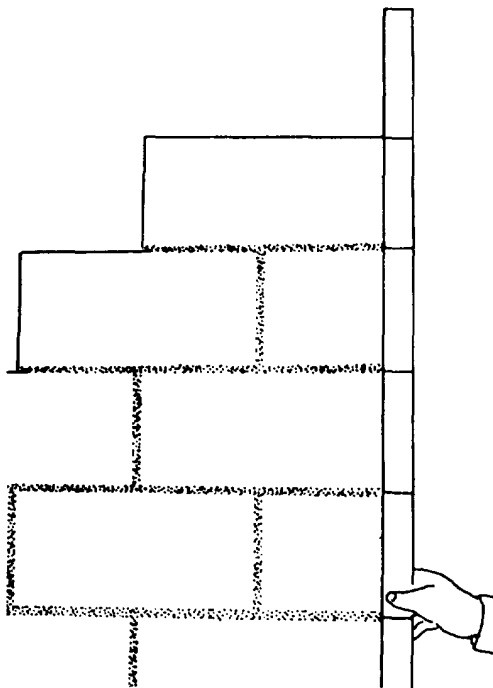

Figure 8-11.-Using a story or course pole.

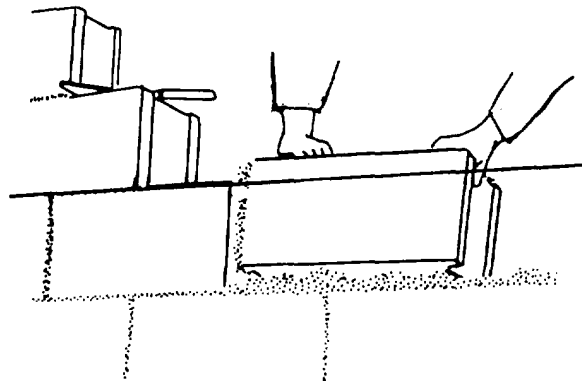

Figure 8-13.-Filling in the wall between corners.

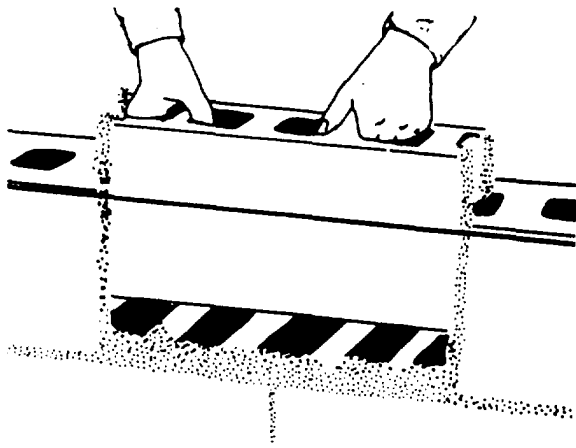

Figure 8-14.-Installing a closure block.

important. First, tip it slightly toward you so that you can see the edge of the course below. Then place the lower edge of the new block directly on the edges of the block below (figure 8-13). Make all position adjustments while the mortar is soft and plastic. Any adjustments you make after the mortar stiffens will break the mortar bond and allow water to penetrate. Level each block and align it to the mason's line by tapping it lightly with a trowel handle.

Fifth and last, before installing the closure block, butter both edges of the opening and all four vertical edges of the closure block with mortar. Then, lower the closure block carefully into place (figure 8-14). If

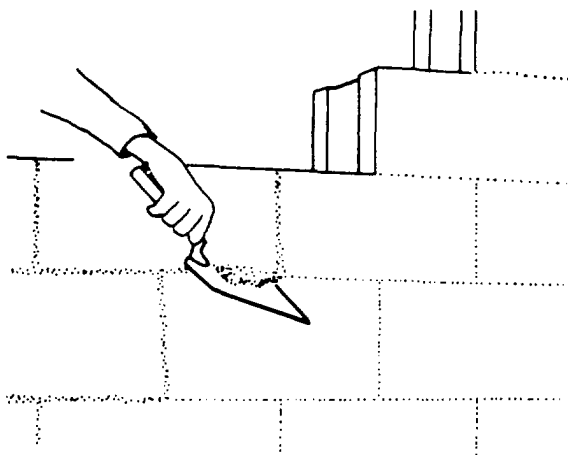

Figure 8-15.-Cutting off excess mortar from the joints.

any mortar falls out, leaving an open joint, remove the block and repeat the procedure.

To assure a good bond, do not spread mortar too far ahead when actually laying blocks. If you do, the mortar will stiffen and lose its plasticity. The recommended width of mortar joints for concrete masonry units is 3/8 inch. When properly made, these joints produce a weathertight, neat, and durable concrete masonry wall. As you lay each block, cut off excess mortar from the joints using a trowel (figure 8-15) and throw it back on the mortar board to rework into the fresh mortar. Do not, however, rework any mortar dropped on the scaffold or floor.

Weathertight joints and the neat appearance of concrete masonry walls depend on proper striking (tooling). After laying a section of the wall, tool the mortar joint when the mortar becomes "thumb print" hard. Tooling compacts the mortar and forces it tightly against the masonry on each side of the joint. Use either concave or V-shaped tooling on all joints (figure 8-16). Tool horizontal joints (figure 8-17, view 1) with a long jointer first, followed by tooling the vertical joints (view 2). Trim off mortar burrs from the tooling flush with the wall face using a trowel, soft bristle brush, or by rubbing with a burlap bag.

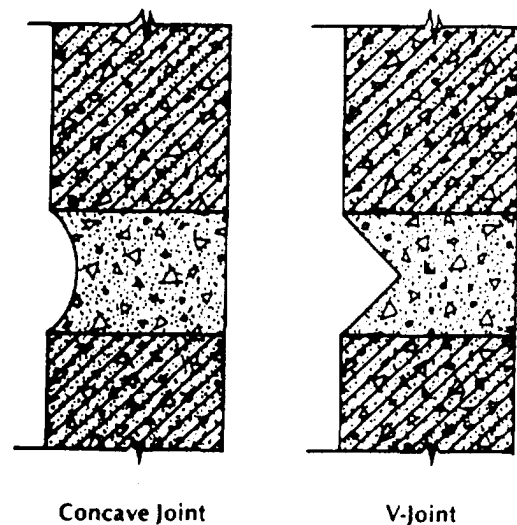
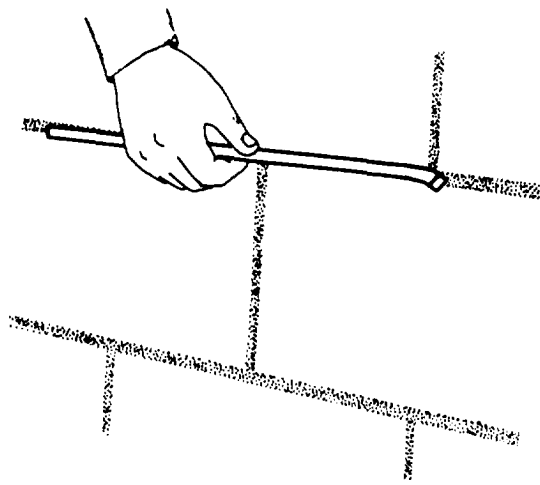
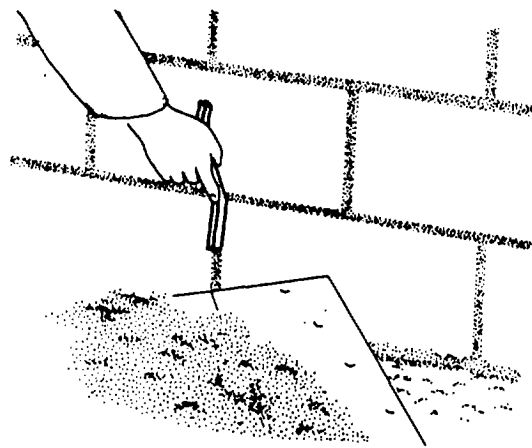

Figure 8-16.-Tooled mortar joints for weathertight exterior walls.



**1. Striking Horizontal Joints**



**2. Striking Vertical Joints**

Figure 8-17.-Tooling mortar joints.

A procedure known as pointing may be required after jointing. Pointing is the process of inserting mortar into horizontal and vertical joints after the unit has been laid. Basically, pointing is done to restore or replace deteriorated surface mortar in old work. Pointing of this nature is called tuck pointing. However, even in freshly laid masonry, pointing may be necessary for filling holes or correcting defective joints.

You must prepare in advance for installing wood plates with anchor bolts on top of hollow concrete masonry walls. To do this, place pieces of metal lath

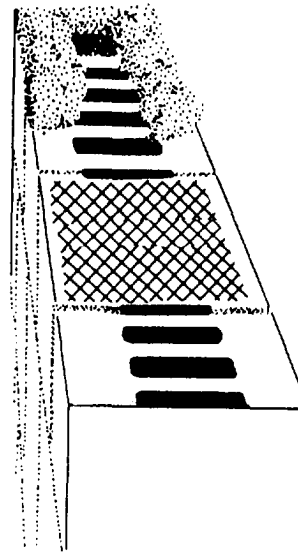

**1. Placing Metal Lath under Cores**

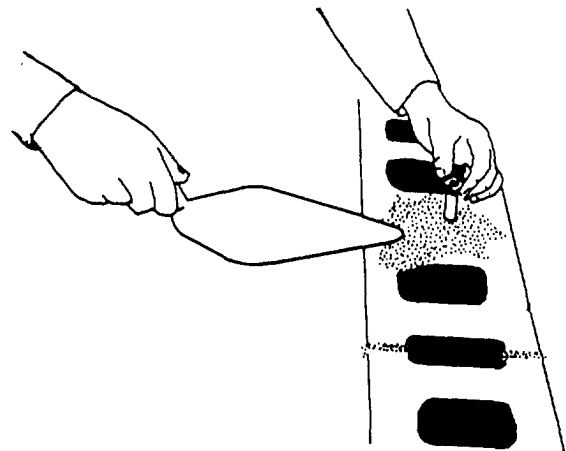

**2. Threaded Bolt End Extends above Wall Top**

Figure 8-18.-Installing anchor bolts for wood plates.

in the second horizontal mortar joint from the top of the wall under the cores that will contain the bolts (figure 8-18, view 1). Use anchor bolts 1/2 inch in diameter and 18 inches long. Space them not more than 4 feet apart. Then, when you complete the top course, insert the bolts into the cores of the top two courses and till the cores with concrete or mortar. The metal lath underneath holds the concrete or mortar filling in place. The threaded end of the bolt should extend above the top of the wall (view 2).

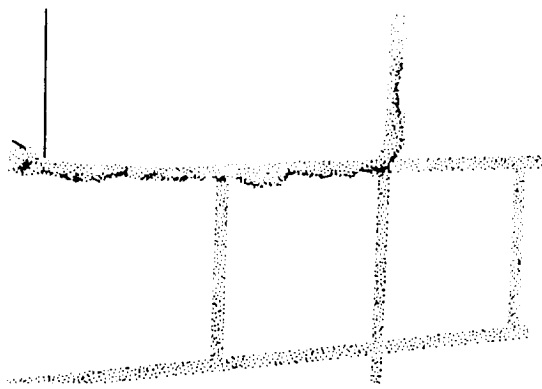

**Full- and Half-Length Blocks  
Make Up Joint**

**Figure 8-19.-Control joints.**

### CONTROL JOINTS

Control joints (figure 8-19) are continuous vertical joints that permit a masonry wall to move slightly under unusual stress without cracking. There are a number of types of control joints built into a concrete masonry wall.

The most preferred control joint is the Michigan type made with roofing felt. A strip of felt is curled into the end core, covering the end of the block on one side of the joint (figure 8-20, view 1). As the other side of the joint is laid, the core is filled with mortar. The filling bonds to one block, but the paper prevents bond to the block on the other side of the control joint.

View 2 of figure 8-20 shows the tongue-and-groove type of control joint. The special units are manufactured in sets consisting of full and half blocks. The tongue of one unit fits into the groove of another unit or into the open end of a regular flanged stretcher. The units are laid in mortar exactly the same as any other masonry units, including mortar in the head joint. Part of the mortar is allowed to remain in the vertical joint to form a backing against which the caulking can be packed.

View 3 shows a control joint that may be built with regular full- and half-length stretcher blocks with a Z-shaped bar across the joint or a 10- or 12-inch pencil rod (1/4-inch smooth bar) across each face shell. If a pencil rod is used, it must be greased on one side of the joint to prevent bond. These rods should be placed every other course. Lay up control joints in mortar just as any other joint. However, if

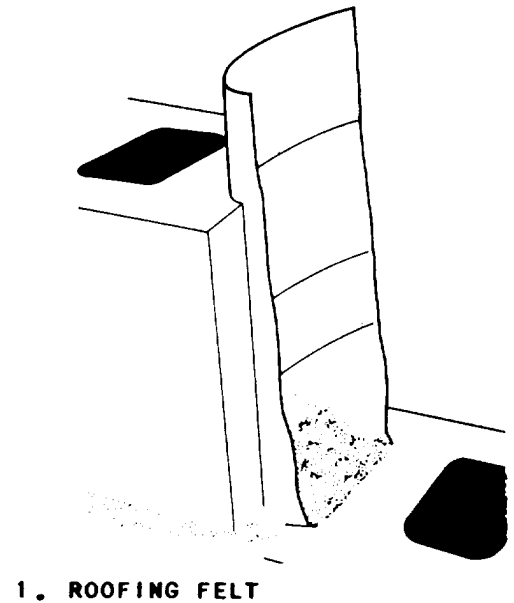

**1. ROOFING FELT**

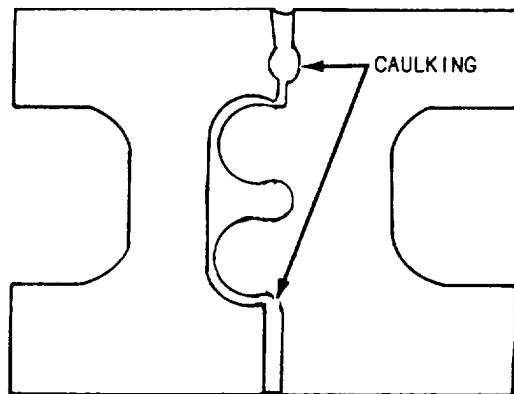

**2. CONTROL JOINT BLOCKS (TOP VIEW)**

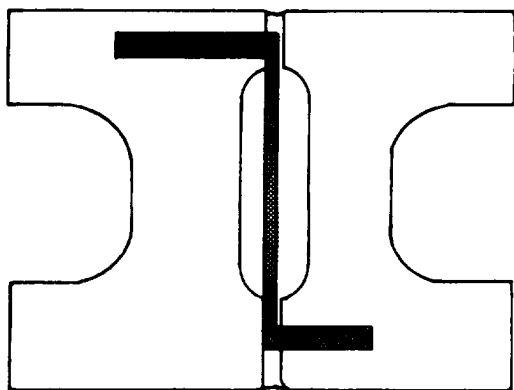

**3. Z BAR JOINT (TOP VIEW)**

**Figure 8-20.-Making control joints.**



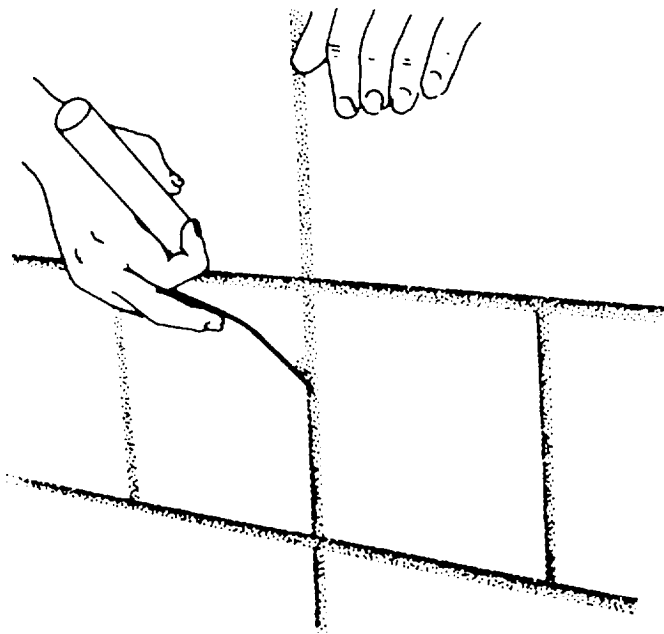

**Raking Joint to Prepare for Caulking**

**Figure 8-21.-Making a control joint.**

they are exposed to either the weather or to view, caulk them as well. After the mortar is stiff, rake it out to a depth of about 3/4-inch to make a recess for the caulking compound. Use a thin, flat caulking trowel to force the compound into the joint (figure 8-21).

The location of control joints is established by the architectural engineer and should be noted in the plans and specifications.

## WALLS

Walls are differentiated into two types: load bearing and nonload bearing. Load-bearing walls not only separate spaces, but also provide structural support for whatever is above them. Nonload bearing walls function solely as partitions between spaces.

### Load-bearing Walls

Do not join intersecting concrete block load-bearing walls with a masonry bond, except at the corners. Instead, terminate one wall at the face of the second wall with a control joint. Then, tie the intersecting walls together with Z-shaped metal tie bars 1/4-by-1/4-by-28 inches in size, having 2-inch right-angle bends on each end (figure 8-22, view 1).

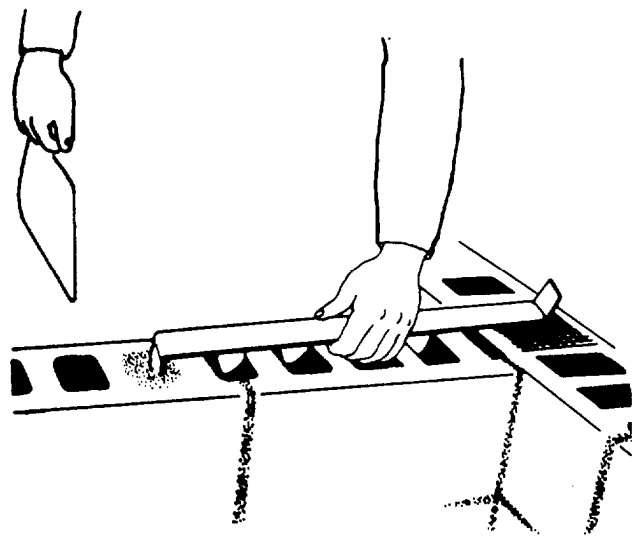

**1. Z-Shaped Tie Bar Has Right Angle Bends at Each End**

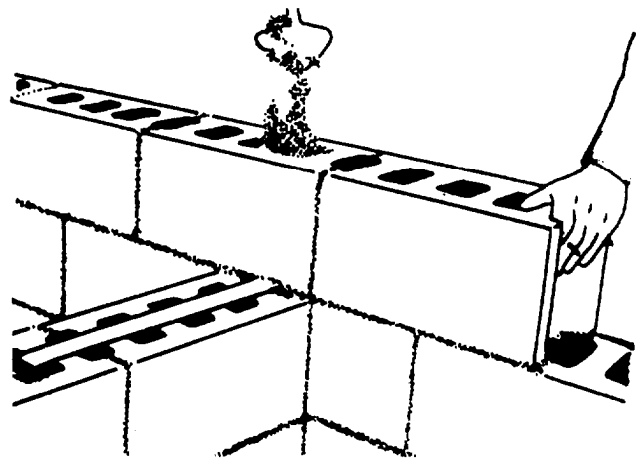

**2. Filling Core With Mortar or Concrete**

**Figure 8-22.-Tying intersecting bearing walls.**

Space the tie bars no more than 4 feet apart vertically and place pieces of metal lath under the block cores that will contain the tie bars ends (figure 8-18, view 1). Embed the right-angle bends in the cores by filling them with mortar or concrete (figure 8-22, view 2).

### Nonload-bearing Walls

To join intersecting nonload-bearing block walls, terminate one wall at the face of the second with a control joint. Then, place strips of metal lath of

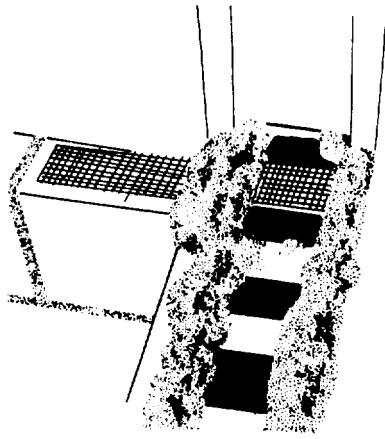

1. Metal Lath Spans the Joint between the Walls

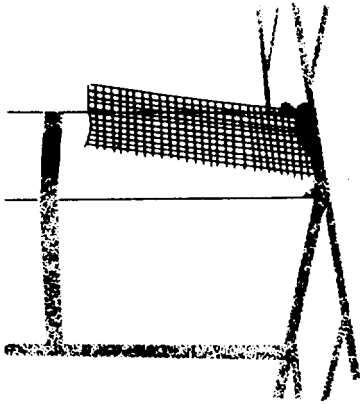

2. Set Lath in the Mortar Joint as You Construct the Second Wall

1/4-inch mesh galvanized hardware cloth across the joint between the two walls (figure 8-23, view 1) in alternate courses. Insert one-half of the metal stops into one wall as you build it, and then tie the other halves into the mortar joints as you lay the second wall (view 2).

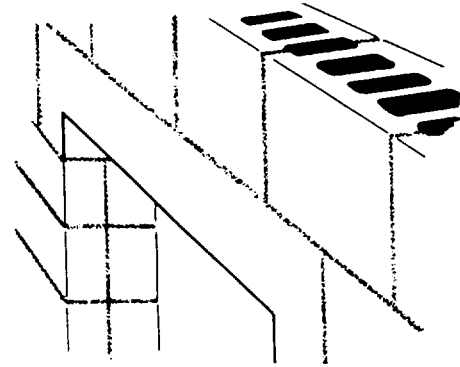

1. Precast Concrete Lintel

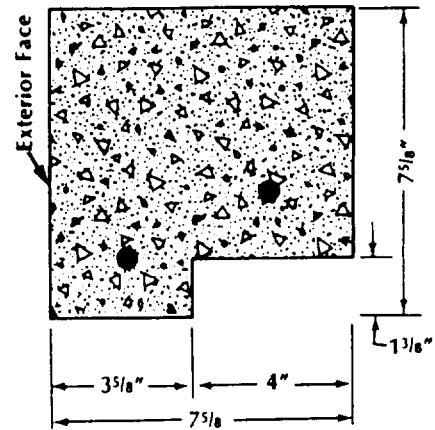

2. Precast Concrete Offset on Lintel Underside

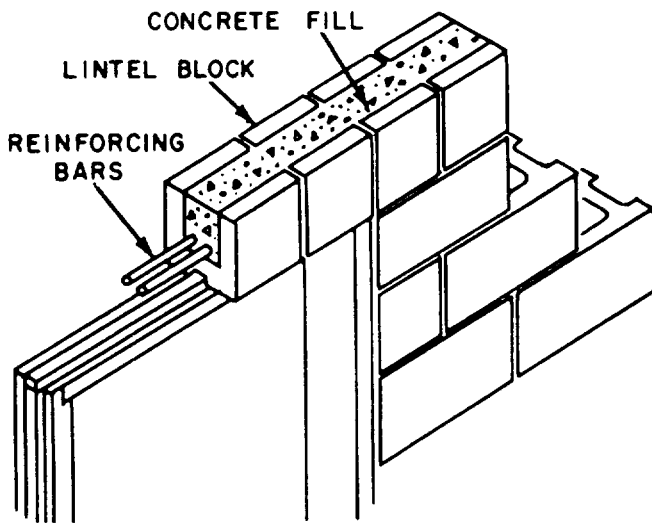
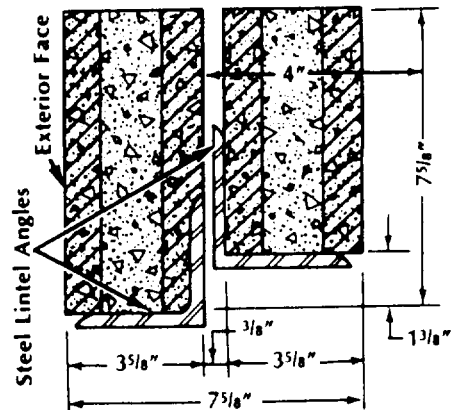

Figure 8-24.-Lintel made from blocks.



3. Steel Angles Offset on Lintel Underside

Figure 8-25.-Installing precast concrete lintels without end with steel angles.

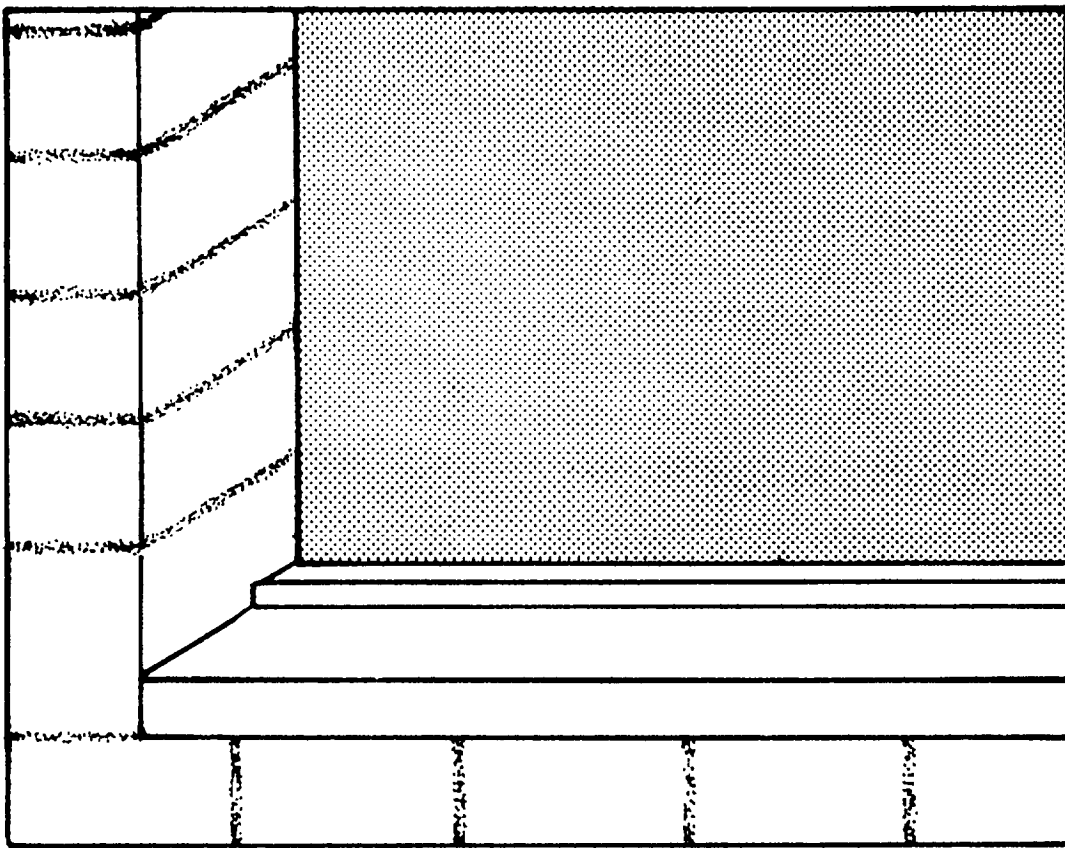

Figure 8-26.-Installed precast concrete sills.

## BOND BEAMS, LINTELS, AND SILLS

Bond beams are reinforced courses of block that bond and integrate a concrete masonry wall into a stronger unit. They increase the bending strength of the wall and are particularly needed to resist the high winds of hurricanes and earthquake forces. In addition, they exert restraint against wall movement, reducing the formation of cracks.

Bond beams are constructed with special-shape masonry units (beam and lintel block) filled with concrete or grout and reinforced with embedded steel bars. These beams are usually located at the top of walls to stiffen them. Since bond beams have appreciable structural strength, they can be located to serve as lintels over doors and windows. Figure 8-24 shows the use of lintel blocks to place a lintel over a metal door, using the door case for support. Lintels should have a minimum bearing of 6 inches at each end. A rule of thumb is to provide 1 inch of bearing for every foot of clear space. When bond beams are located just above the floor, they act to distribute the wall weight (making the wall a deep beam) and thus

help avoid wall cracks if the floor sags. Bond beams may also be located below a window sill.

Modular door and window openings usually require lintels to support the blocks over the openings. You can use precast concrete lintels (figure 8-25, view 1) that contain an offset on the underside (view 2) to fit the modular openings. You can also use steel lintel angles that you install with an offset on the underside (view 3) to fit modular openings. In either case, place a noncorroding metal plate under the lintel ends at the control joints to allow the lintel to slip and the control joints to function properly. Apply a full bed of mortar over the metal plate to uniformly distribute the lintel load.

You usually install precast concrete sills (figure 8-26) following wall construction. Fill the joints tightly at the ends of the sills with mortar or a caulking compound.

## PIERS AND PILASTERS

Piers are isolated columns of masonry, whereas pilasters are columns or thickened wall sections built contiguous to and forming part of a masonry wall.

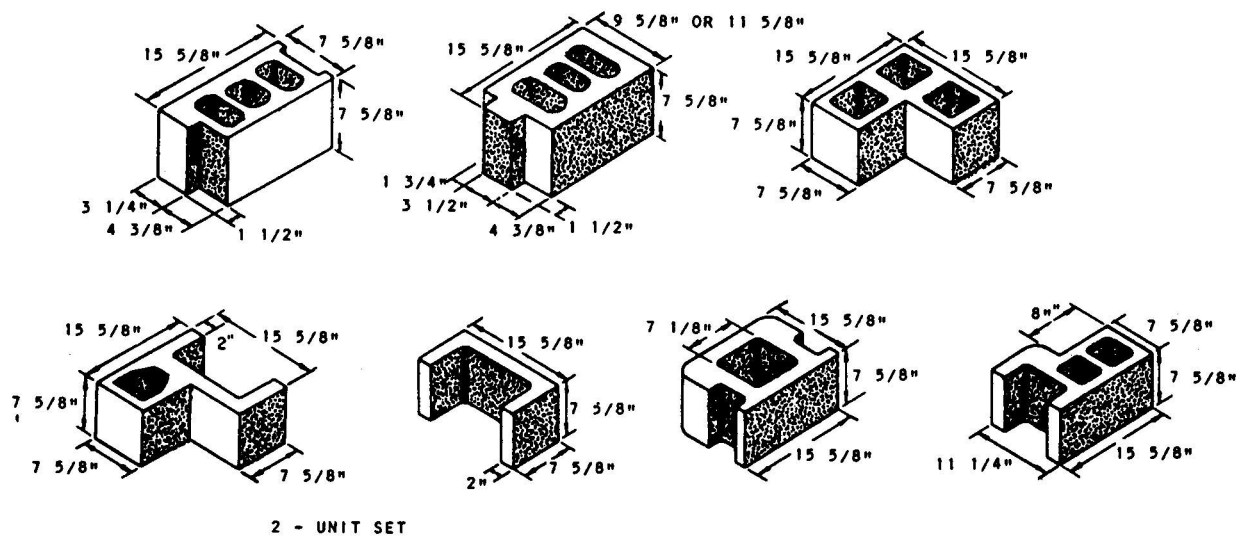

**A. UNITS FOR SPECIAL CONDITIONS**

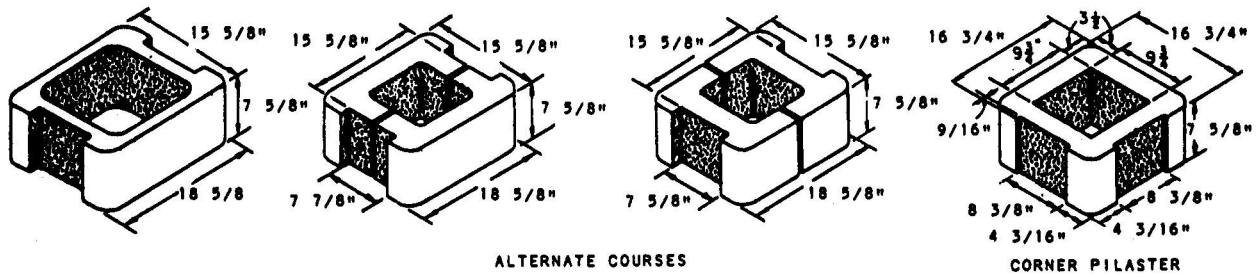

**B. UNITS FOR 8-IN. WALLS**

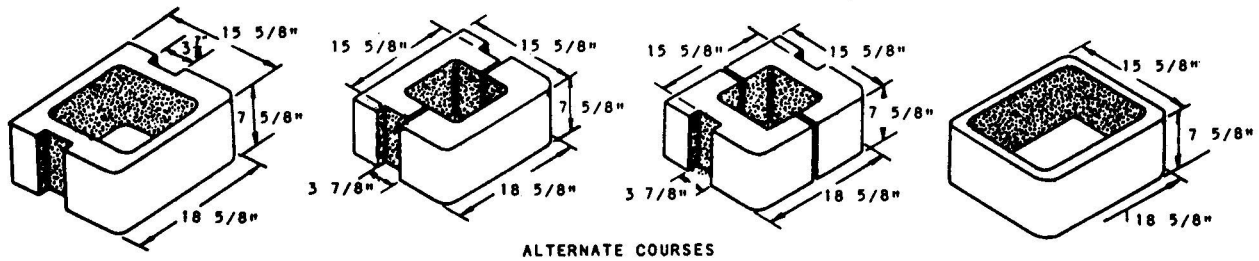

**C. UNITS FOR KEY OR WOOD JAMB BLOCK**

**D. DOUBLE BULLNOSE PIER BLOCK**

Figure 8-27.—Pilaster masonry units.

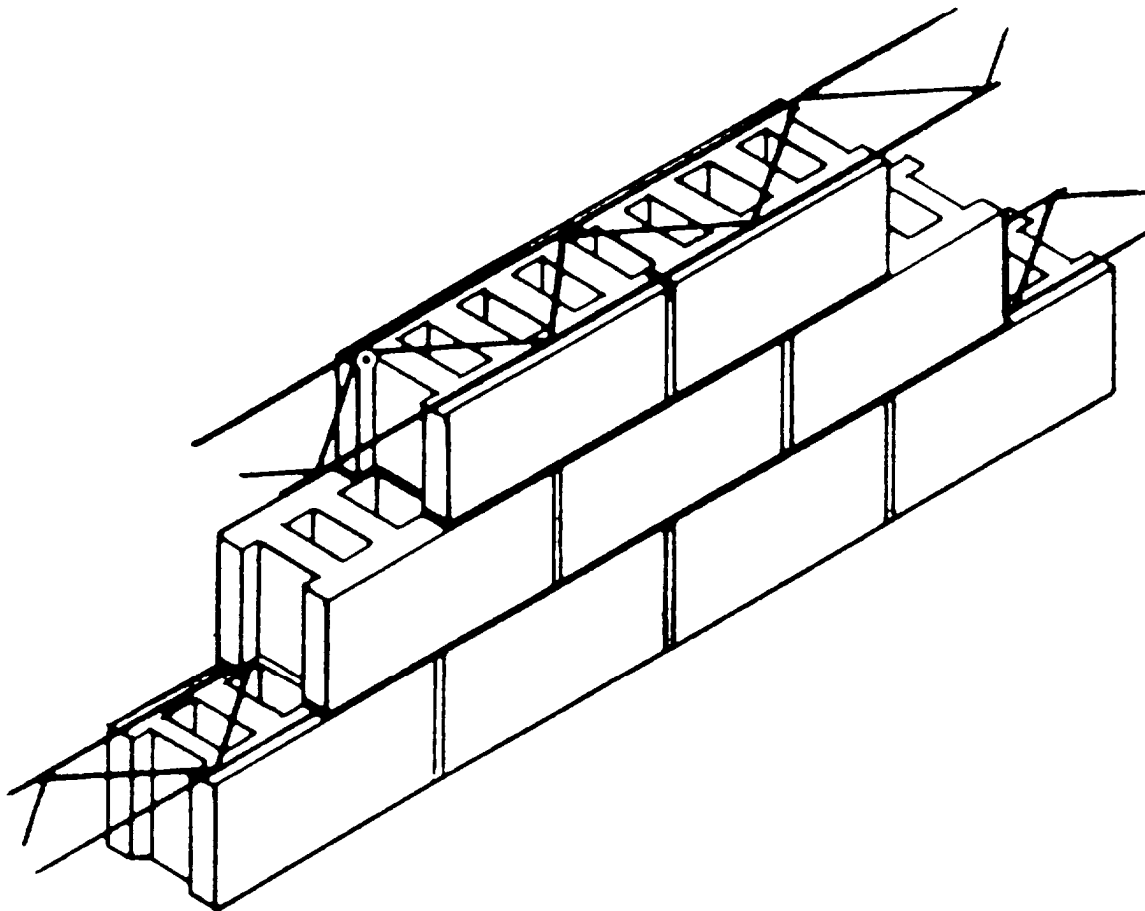

Figure 8-28.-Masonry wall horizontal joint reinforcement.

Both piers and pilasters are used to support heavy, concentrated vertical roof or floor loads. They also provide lateral support to the walls. Piers and pilasters offer an economic advantage by permitting construction of higher and thinner walls. They may be constructed of special concrete masonry units (figure 8-27) or standard units.

### REINFORCED BLOCKWALLS

Block walls may be reinforced vertically or horizontally. To reinforce vertically, place reinforcing rods (called rebar) into the cores at the specified spacing and fill the cores with a relatively high-slump concrete. Rebar should be placed at each corner and at both sides of each opening. Vertical rebar should be spaced a maximum of 32 inches on center in walls. Where splices are required, the bars should be lapped 40 times the bar diameter. The concrete should be placed in one continuous pour from foundation to plate line. A cleanout block may be placed in the first course at every rebar stud for cleaning out excess

mortar and to ensure proper alignment and laps of rebars.

Practical experience indicates that control of cracking and wall flexibility can be achieved with the use of horizontal joint reinforcing. The amount of joint reinforcement depends largely upon the type of construction. Horizontal joint reinforcing, where required, should consist of not less than two deformed longitudinal No. 9 or heavier cold-drawn steel wires. Truss-type cross wires should be 1/8-inch diameter (or heavier) of the same quality. Figure 8-28 shows joint reinforcement on 16-inch vertical spacing. The location and details of bond beams, control joints, and joint reinforcing should all be shown on the drawings.

### PATCHING AND CLEANING BLOCK WALLS

Always fill holes made by nails or line pins with fresh mortar and patch mortar joints. When laying concrete masonry walls, **be careful not to smear mortar on the block surfaces.** Once they harden, these smears cannot be removed, even with an acid

wash, nor will paint cover them. Allow droppings to dry and harden. You can then chip off most of the mortar with a small piece of broken concrete block (figure 8-29, view 1) or with a trowel (view 2). A final brushing of the spot removes practically all the mortar (view 3).

## RETAINING WALLS

The purpose of a retaining wall is to hold back a mass of soil or other material. As a result, concrete masonry retaining walls must have the structural strength to resist imposed vertical and lateral loads. The footing of a retaining wall should be large enough to support the wall and the load of the material that the wall is to retain. The reinforcing must be properly located as specified in the plans. Provisions to prevent the accumulation of water behind retaining

walls should be made. This includes the installation of drain tiles or weep holes, or both.

## PAINTING CONCRETE MASONRY

Several finishes are possible with concrete masonry construction. The finish to use in any specific situation should be governed by the type of structure in which the walls will be used and the climatic conditions to which they will be exposed.

Paints now commonly used on concrete masonry walls include portland cement paint, latex paint, oil-based paint, and rubber-based paint. For proper application and preparation of the different types of paint, refer to the plans, specifications, or manufacturer's instructions.

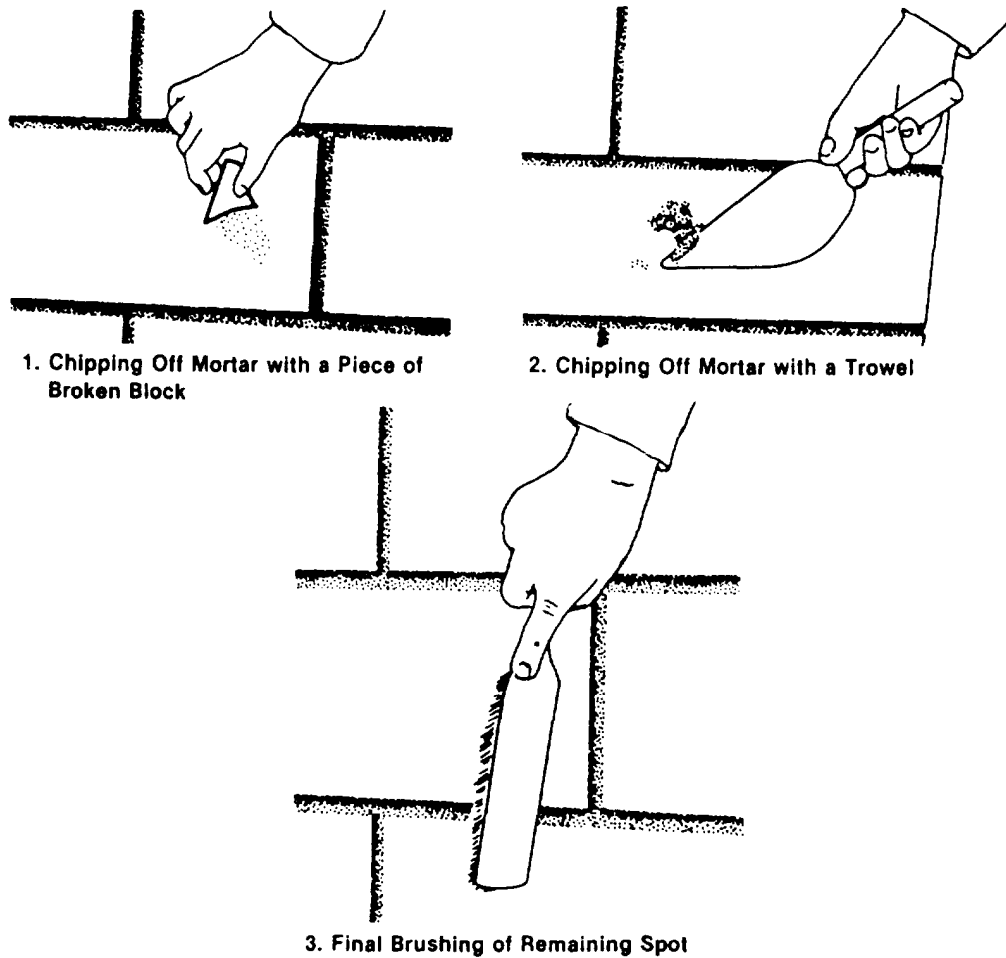

Figure 8-29.-Cleaning mortar droppings from a concrete block wall.

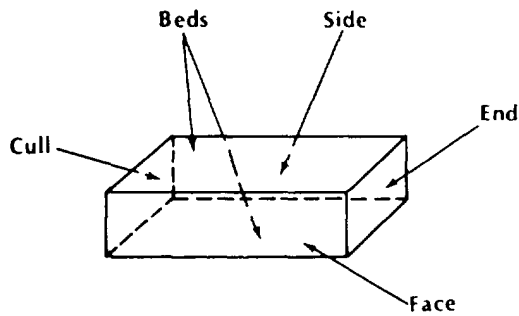

Figure 8-30.-Names of brick surfaces.

## BRICK MASONRY

*LEARNING OBJECTIVE: Upon completing this section, you should be able to explain the elements of brick masonry.*

Brick masonry is construction in which uniform units ("bricks"), small enough to be placed with one hand, are laid in courses with mortar joints to form walls. Bricks are kiln baked from various clay and shale mixtures. The chemical and physical characteristics of the ingredients vary considerably. These characteristics and the kiln temperatures combine to produce brick in a variety of colors and harnesses. In some regions, individual pits yield clay or shale which, when ground and moistened, can be formed and baked into durable brick. In other regions, clay or shale from several pits must be mixed.

## BRICK TERMINOLOGY

Standard U.S. bricks are 2 1/4-by-3 3/4-by-8 inches nominal size. They may have three core holes or ten core holes. Modular U.S. bricks are 2 1/4-by-3 5/8-by-7 5/8 inches nominal size. They usually have three core holes. English bricks are 3-by-4 1/2-by-9 inches; Roman bricks are 1 1/2-by-4-by-12 inches; and Norman bricks are 2 3/4-by-4-by-12 inches nominal size. Actual brick dimensions are smaller, usually by an amount equal to a mortar joint width. Bricks weigh from 100 to 150 pounds per cubic foot, depending on the ingredients and duration of firing. Fired brick is heavier than under-burned brick. The six surfaces of a brick are called cull, beds, side, end, and face, as shown in figure 8-30.

Occasionally you will have to cut brick into various shapes to fill in spaces at corners and other locations where a full brick does not fit. Figure 8-31 shows the more common cut shapes: half or bat,

three-quarter closure, quarter closure, king closure, queen closure, and split.

## TYPES OF BRICKS

Brick masonry units may be solid, hollow, or architectural terra cotta. All types can serve a structural function, a decorative function, or a combination of both. The various types differ in their formation and composition.

Building brick, also called common, hard, or kiln-run brick, is made from ordinary clay or shale and is fired in kilns. These bricks have no special shoring, markings, surface texture, or color. Because building bricks are generally used as the backing courses in either solid or cavity brick walls, the harder and more durable types are preferred.

Face brick is better quality and has better durability and appearance than building brick. Because of this, face bricks are used in exposed wall faces. The most common face brick colors are various shades of brown, red, gray, yellow, and white.

Clinker brick is over burned in the kiln. Clinker bricks are usually rough, hard, durable, and sometimes irregular in shape.

Pressed brick is made by a dry-press process rather than by kiln firing. Pressed bricks have regular smooth faces, sharp edges, and perfectly square corners. Ordinarily, they are used like face brick.

Glazed brick has one surface coated with a white or colored ceramic glazing. The glazing forms when mineral ingredients fuse together in a glass like coating during burning. Glazed bricks are particularly

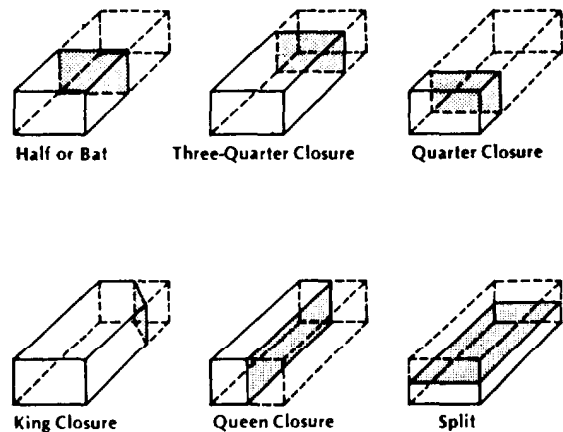

Figure 8-31.-Common cut brick shapes.

suitable to walls or partitions in hospitals, dairies, laboratories, and other structures requiring sanitary conditions and ease of cleaning.

Fire brick is made from a special type of clay. This clay is very pure and uniform and is able to withstand the high temperatures of fireplaces, boilers, and similar constructions. Fire bricks are generally larger than other structural bricks and are often hand molded.

Cored bricks have ten holes—two rows of five holes each—extending through their beds to reduce weight. Walls built from cored brick are not much different in strength than walls built from solid brick. Also, both have about the same resistance to moisture penetration. Whether cored or solid, use the more available brick that meets building requirements.

European brick has strength and durability about equal to U.S. clay brick. This is particularly true of the English and Dutch types.

Sand-lime brick is made from a lean mixture of slaked lime and fine sand. Sand-lime bricks are molded under mechanical pressure and are hardened under steam pressure. These bricks are used extensively in Germany.

## **STRENGTH OF BRICK MASONRY**

The main factors governing the strength of a brick structure include brick strength, mortar strength and elasticity, bricklayer workmanship, brick uniformity, and the method used to lay brick. In this section, we'll cover strength and elasticity. Workmanship is covered separately in the next section.

The strength of a single brick masonry unit varies widely, depending on its ingredients and manufacturing method. Brick can have an ultimate compressive strength as low as 1,600 psi. On the other hand, some well-burned brick has compressive strength exceeding 15,000 psi.

Because portland-cement-lime mortar is normally stronger than the brick, brick masonry laid with this mortar is stronger than an individual brick unit. The load-carrying capacity of a wall or column made with plain lime mortar is less than half that made with portland-cement-lime mortar. The compressive working strength of a brick wall or column laid with plain lime mortar normally ranges from 500 to 600 psi.

For mortar to bond to brick properly, sufficient water must be present to completely hydrate the

portland cement in the mortar. Bricks sometimes have high absorption rates, and, if not properly treated, can "suck" the water out of the mortar, preventing complete hydration. Here is a quick field test to determine brick absorptive qualities. Using a medicine dropper, place 20 drops of water in a 1-inch circle (about the size of a quarter) on a brick. A brick that absorbs all the water in less than 1 1/2 minutes will suck the water out of the mortar when laid. To correct this condition, thoroughly wet the bricks and allow time for the surfaces to air-dry before placing.

## **BRICKLAYING METHODS**

Good bricklaying procedure depends on good workmanship and efficiency. Efficiency involves doing the work with the fewest possible motions. Each motion should have a purpose and should accomplish a definite result. After learning the fundamentals, every Builder should develop methods for achieving maximum efficiency. The work must be arranged in such a way that the Builder is continually supplied with brick and mortar. The scaffolding required must be planned before the work begins. It must be built in such a way as to cause the least interference with other crewmembers.

Bricks should always be stacked on planks; they should never be piled directly on uneven or soft ground. Do not store bricks on scaffolds or runways. This does not, however, prohibit placing normal supplies on scaffolding during actual bricklaying operations. Except where stacked in sheds, brick piles should never be more than 7 feet high. When a pile of brick reaches a height of 4 feet, it must be tapered back 1 inch in every foot of height above the 4-foot level. The tops of brick piles must be kept level, and the taper must be maintained during unloading operations.

## **MASONRY TERMS**

To efficiently and effectively lay bricks, you must be familiar with the terms that identify the position of masonry units and mortar joints in a wall. The following list, which is referenced to figure 8-32, provides some of the basic terms you will encounter.

- **Course**— One of several continuous, horizontal layers (or rows) of masonry units bonded together.



- **Wythe**— Each continuous, vertical section of a wall, one masonry unit thick. Sometimes called a tier.
- **Stretcher**— A masonry unit laid flat on its bed along the length of a wall with its face parallel to the face of the wall.
- **Header**— A masonry unit laid flat on its bed across the width of a wall with its face perpendicular to the face of the wall. Generally used to bond two wythes.
- **Row lock**— A header laid on its face or edge across the width of a wall.
- **Bull header**— A rowlock brick laid with its bed perpendicular to the face of the wall.

- **Bull stretcher**— A rowlock brick laid with its bed parallel to the face of the wall.
- **Soldier**— A brick laid on its end with its face perpendicular to the face of the wall.

## BONDS

The term “bond” as used in masonry has three different meanings: structural bond, mortar bond, or pattern bond.

Structural bond refers to how the individual masonry units interlock or tie together into a single structural unit. You can achieve structural bonding of brick and tile walls in one of three ways:

- Overlapping (interlocking) the masonry units;
- Embedding metal ties in connecting joints; and

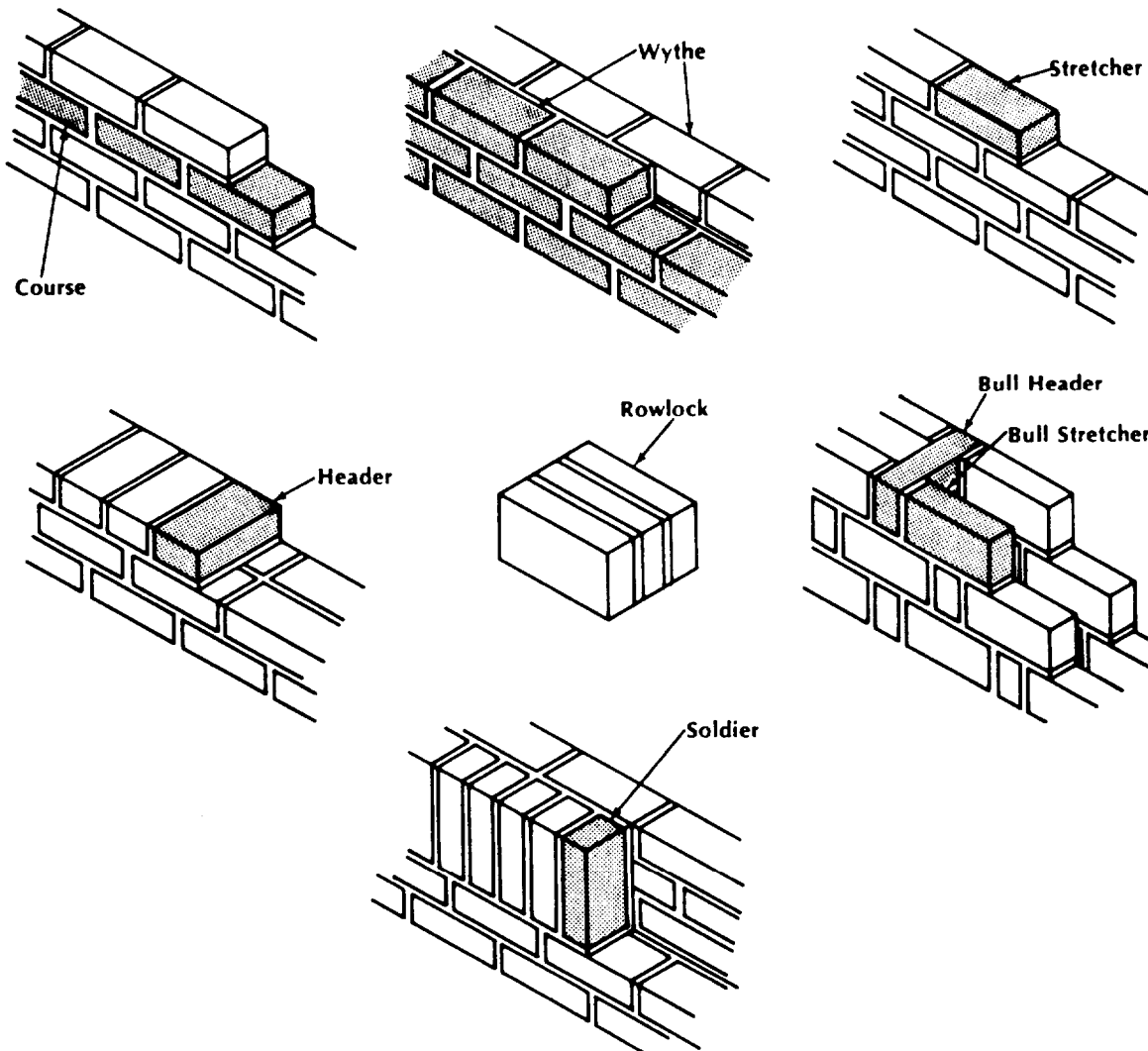

Figure 8-32.-Masonry units and mortar joints.

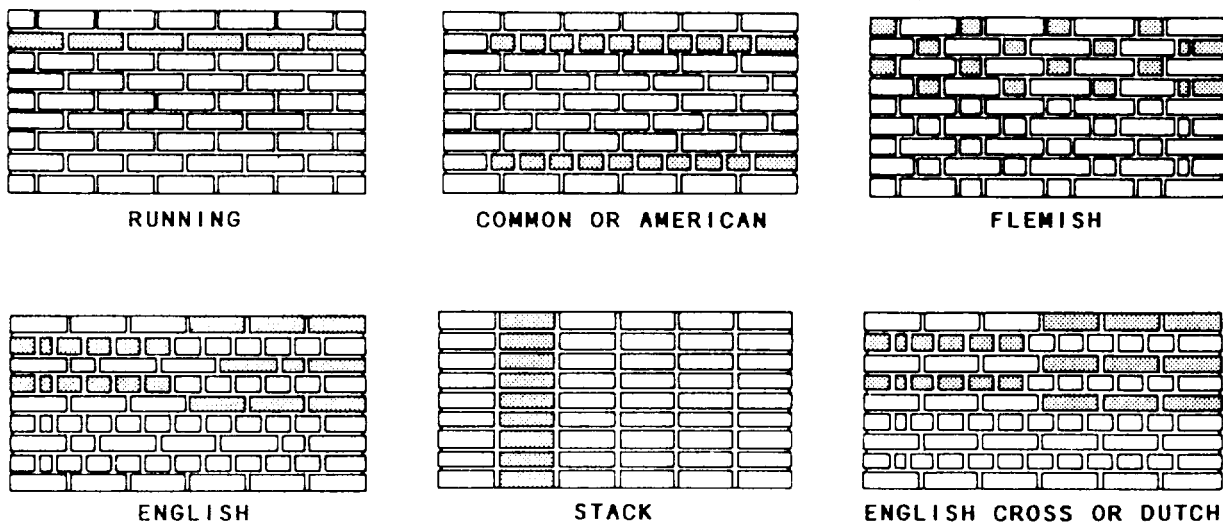

Figure 8-33.-Types of masonry bonds.

- Using grout to adhere adjacent wythes of masonry.

Mortar bond refers to the adhesion of the joint mortar to the masonry units or to the reinforcing steel.

Pattern bond refers to the pattern formed by the masonry units and mortar joints on the face of a wall. The pattern may result from the structural bond, or may be purely decorative and unrelated to the structural bond. Figure 8-33 shows the six basic pattern bonds in common use today: running, common or American, Flemish, English, stack, and English cross or Dutch bond.

The running bond is the simplest of the six patterns, consisting of all stretchers. Because the bond has no headers, metal ties usually form the structural bond. The running bond is used largely in cavity wall construction, brick veneer walls, and facing tile walls made with extra wide stretcher tile.

The common, or American, bond is a variation of the running bond, having a course of full-length headers at regular intervals that provide the structural bond as well as the pattern. Header courses usually appear at every fifth, sixth, or seventh course, depending on the structural bonding requirements. You can vary the common bond with a Flemish header course. In laying out any bond pattern, be sure to start the corners correctly. In a common bond, use a three-quarter closure at the corner of each header course.

In the Flemish bond, each course consists of alternating headers and stretchers. The headers in every other course center over and under the stretchers in the courses in between. The joints

between stretchers in all stretcher courses align vertically. When headers are not required for structural bonding, you can use bricks called blind headers. You can start the corners in two different ways. In the Dutch corner, a three-quarter closure starts each course. In the English corner, a 2-inch or quarter closure starts the course.

The English bond consists of alternating courses of headers and stretchers. The headers center over and under the stretchers. However, the joints between stretchers in all stretcher courses do not align vertically. You can use blind headers in courses that are not structural bonding courses.

The stack bond is purely a pattern bond, with no overlapping units and all vertical joints aligning. You must use dimensionally accurate or carefully rematched units to achieve good vertical joint alignment. You can vary the pattern with combinations and modifications of the basic patterns shown in figure 8-33. This pattern usually bonds to the backing with rigid steel ties or 8-inch-thick stretcher units when available. In large wall areas or load-bearing construction, insert steel pencil rods into the horizontal mortar joints as reinforcement.

The English cross or Dutch bond is a variation of the English bond. It differs only in that the joints between the stretchers in the stretcher courses align vertically. These joints center on the headers in the courses above and below.

When a wall bond has no header courses, use metal ties to bond the exterior wall brick to the backing courses. Figure 8-34 shows three typical metal ties.

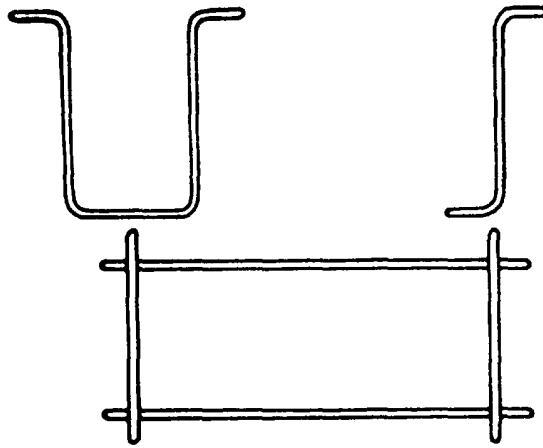

Figure 8-34.-Metal ties.

Install flashing at any spot where moisture is likely to enter a brick masonry structure. Flashing diverts the moisture back outside. Always install flashing under horizontal masonry surfaces, such as sills and copings; at intersections between masonry walls and horizontal surfaces, such as a roof and parapet or a roof and chimney; above openings (doors and windows, for example); and frequently at floor lines, depending on the type of construction. The flashing should extend through the exterior wall face and then turn downward against the wall face to form a drop.

You should provide weep holes at intervals of 18 to 24 inches to drain water to the outside that might accumulate on the flashing. Weep holes are even more important when appearance requires the flashing to stop behind the wall face instead of extending through the wall. This type of concealed flashing, when combined with tooled mortar joints, often retains water in the wall for long periods and, by concentrating the moisture at one spot, does more harm than good.

### MORTAR JOINTS AND POINTING

There is no set rule governing the thickness of a brick masonry mortar joint. Irregularly shaped bricks may require mortar joints up to 1/2 inch thick to compensate for the irregularities. However, mortar joints 1/4 inch thick are the strongest. Use this thickness when the bricks are regular enough in shape to permit it.

A slushed joint is made simply by depositing the mortar on top of the head joints and allowing it to run down between the bricks to form a joint. You cannot make solid joints this way. Even if you fill the space between the bricks completely, there is no way you can compact the mortar against the brick faces; consequently a poor bond results. The only effective way to build a good joint is to trowel it.

The secret of mortar joint construction and pointing is in how you hold the trowel for spreading mortar. Figure 8-35 shows the correct way to hold a trowel. Hold it firmly in the grip shown, with your

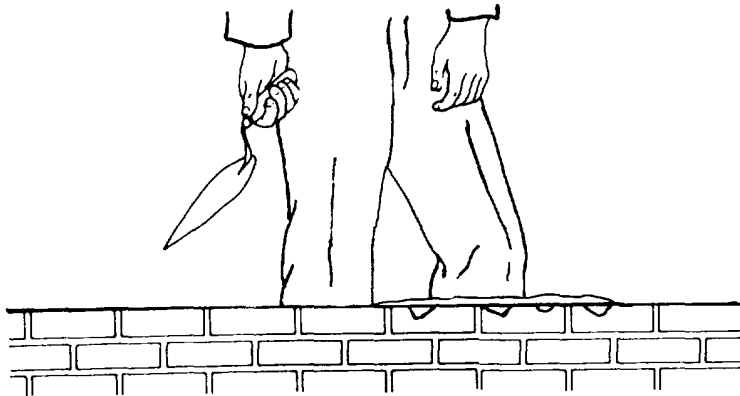
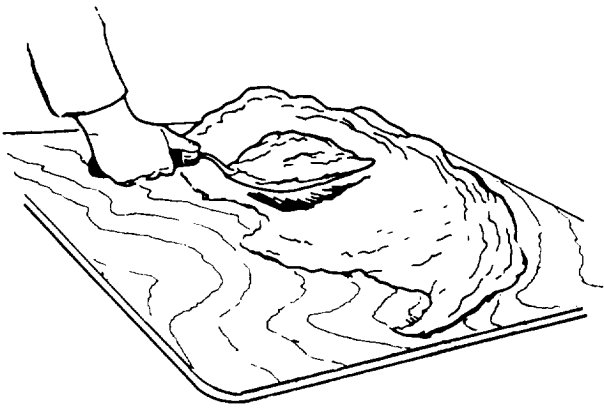
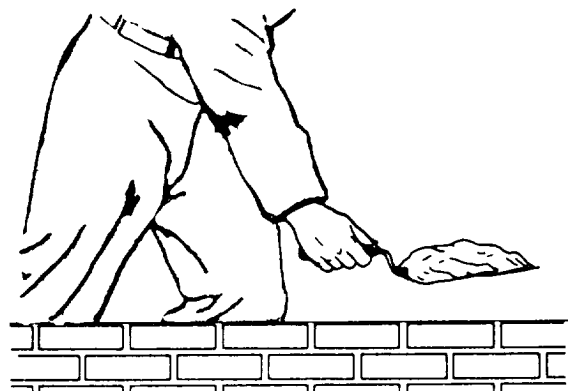

Figure 8-35.-Correct way to hold a trowel.



**1. Proper Way to Pick Up Mortar Right-Handed**



**2. Fully-Loaded Trowel for Five Bricks**

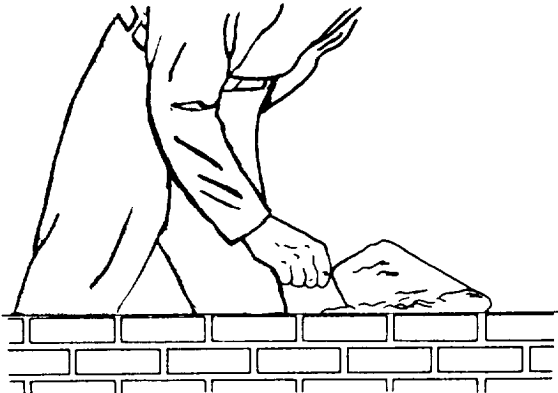

**3. Working from Left to Right**

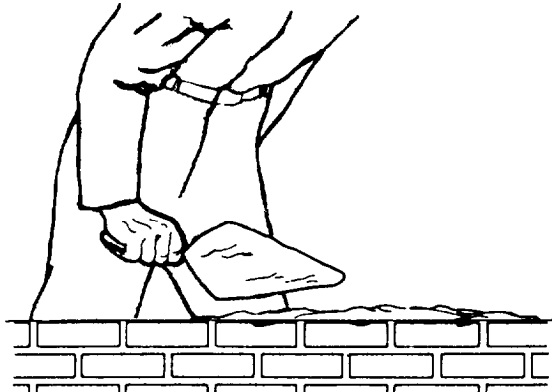

**4. Spreading Mortar on Three to Five Bricks at a Time**

**Figure 8-36.-Picking up and spreading mortar.**

thumb resting on top of the handle, not encircling it. If you are right-handed, pick up mortar from the outside of the mortar board pile with the left edge of your trowel (figure 8-36, view 1). You can pick up enough to spread one to five bricks, depending on the wall space and your skill. A pickup for one brick forms only a small pile along the left edge of the trowel. A pickup for five bricks is a full load for a large trowel (view 2).

If you are right-handed, work from left to right along the wall. Holding the left edge of the trowel directly over the center line of the previous course, tilt the trowel slightly and move it to the right (view 3), spreading an equal amount of mortar on each brick until you either complete the course or the trowel is empty (view 4). Return any mortar left over to the mortar board.

Do not spread the mortar for a bed joint too far ahead of laying—four or five brick lengths is best. Mortar spread out too far ahead dries out before the

bricks become bedded and causes a poor bond (figure 8-37). The mortar must be soft and plastic so that the brick will bed in it easily. Spread the mortar about 1 inch thick and then make a shallow furrow in

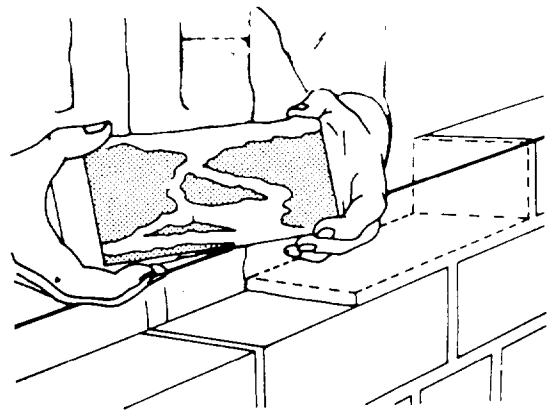

**Figure 8-37.-A poorly bonded brick.**

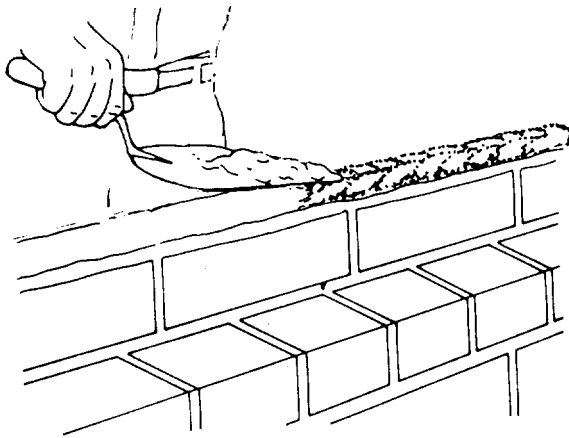

1. Making a Furrow

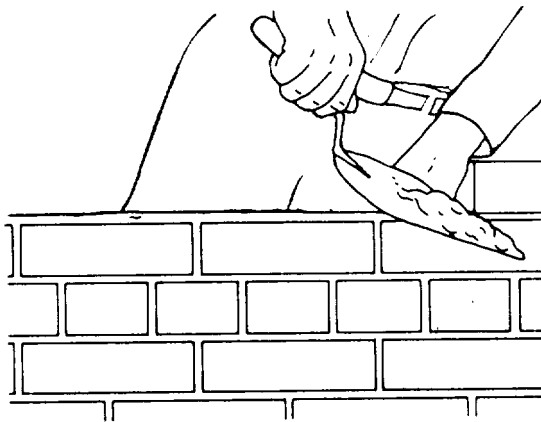

2. Cutting Off Excess Mortar

Figure 8-38.-Making a bed joint in a stretcher course.

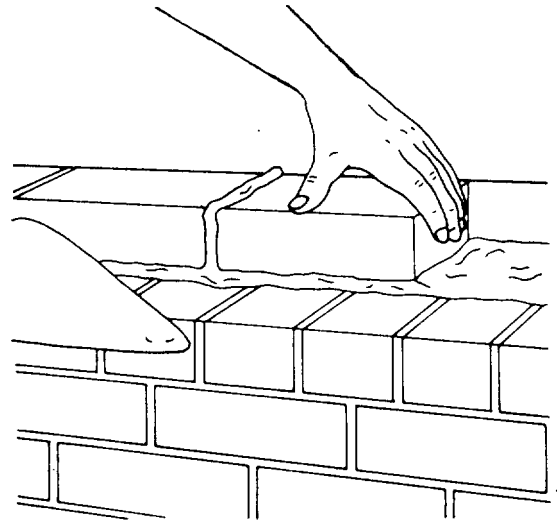

Figure 8-40.-Making a head joint in a stretcher course.

it (figure 8-38, view 1). A furrow that is too deep leaves a gap between the mortar and the bedded brick. This reduces the resistance of the wall to water penetration.

Using a smooth, even stroke, cut off any mortar projecting beyond the wall line with the edge of the trowel (figure 8-38, view 2). Retain enough mortar on the trowel to butter the left end of the first brick you will lay in the fresh mortar. Throw the rest back on the mortar board.

Pick up the first brick to be laid with your thumb on one side of the brick and your fingers on the other (figure 8-39). Apply as much mortar as will stick to the end of the brick and then push it into place. Squeeze out the excess mortar at the head joint and at the sides (figure 8-40). Make sure the mortar

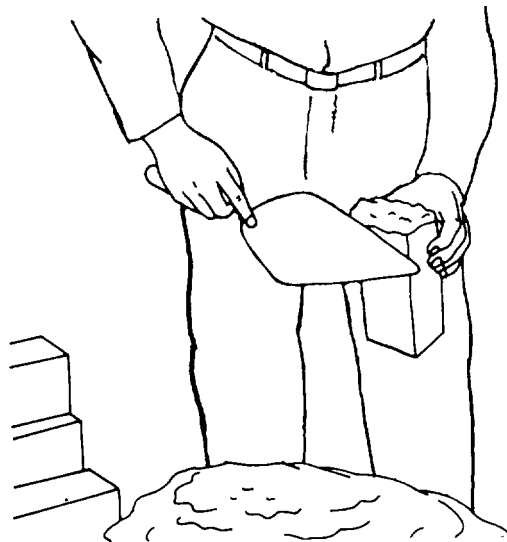
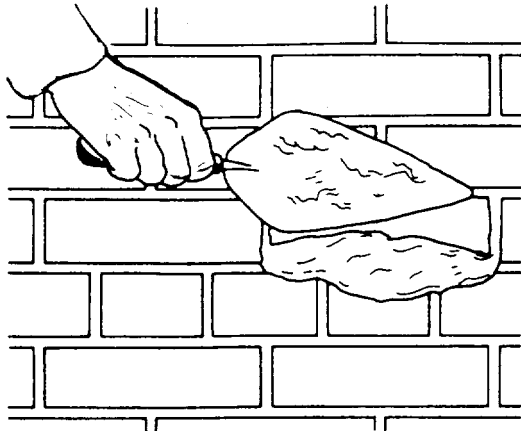

Figure 8-39.-Proper way to hold a brick when buttering the end.

completely fills the head joint. After bedding the brick, cut off the excess mortar and use it to start the next end joint. Throw any surplus mortar back on the mortar board where it can be restored to workability.

Figure 8-41 shows how to insert a brick into a space left in a wall. First, spread a thick bed of mortar (view 1), and then shove the brick into the wall space



**1. Spreading a Thick Bed of Mortar**

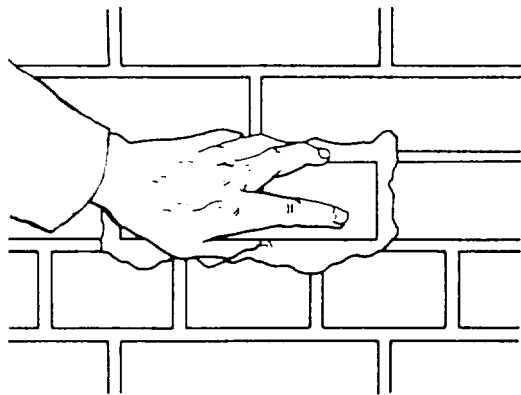

**2. Shoving the Brick into Place**

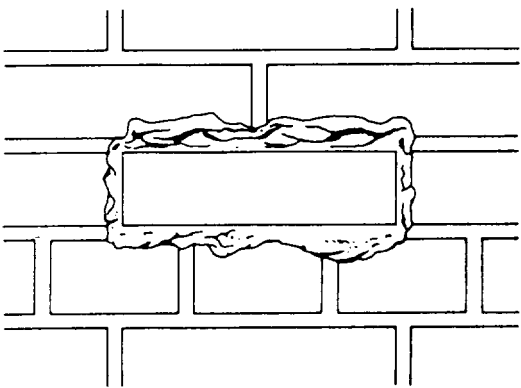

**3. Mortar Squeezes Out All Four Joints**

Figure 8-41.-Inserting a brick in a wall space.

(view 2) until mortar squeezes out of all four joints (view 3). This way, you know that the joints are full of mortar at every point.

To make a cross joint in a header course, spread the bed joint mortar several brick widths in advance. Then, spread mortar over the face of the header brick before placing it in the wall (figure 8-42, view 1). Next, shove the brick into place, squeezing out mortar at the top of the joint. Finally, cut off the excess mortar as shown in view 2.

Figure 8-43 shows how to lay a closure brick in a header course. First, spread about 1 inch of mortar on the sides of the brick already in place (view 1), as well

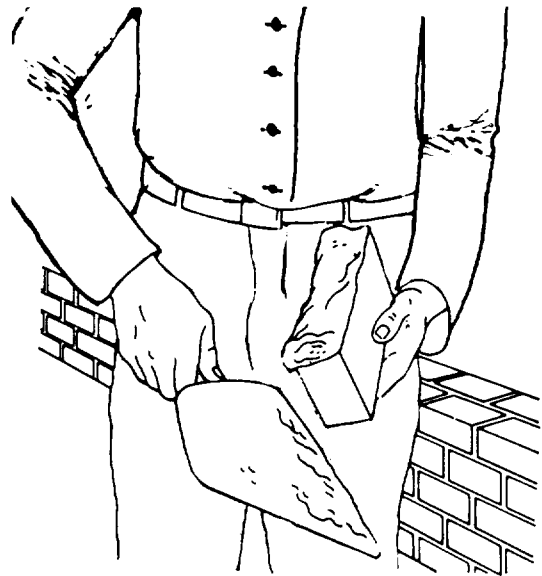

**1. Spreading Mortar over Brick Face**

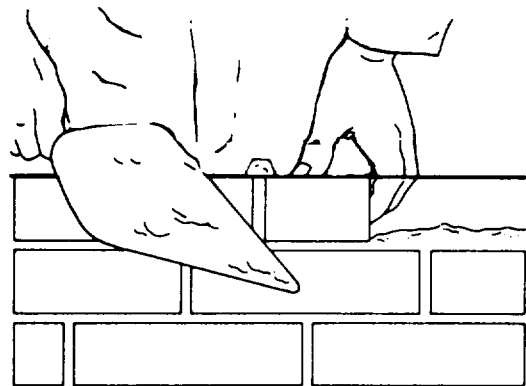

**2. Cutting Off Excess Mortar**

Figure 8-42.-Making a cross joint in a header course.

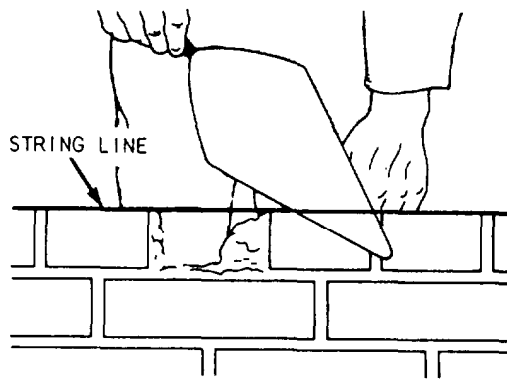

**1. Spreading Mortar on Sides of Brick Already Laid**

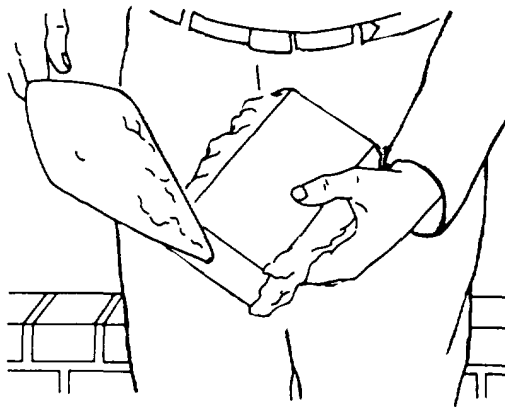

**2. Spreading Mortar on Both Sides of Closure Brick**

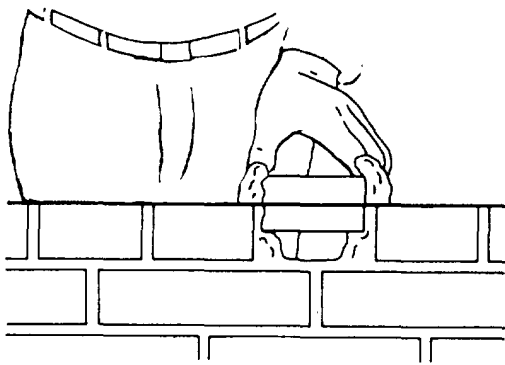

**3. Laying the Brick into Position**

Figure 8-43.-Making a closure joint in a header course.

as on both sides of the closure brick (view 2). Then, lay the closure brick carefully into position without disturbing the brick already laid (view 3). If you do disturb any adjacent brick, cracks will form between the brick and mortar, allowing moisture to penetrate the wall. You should place a closure brick for a

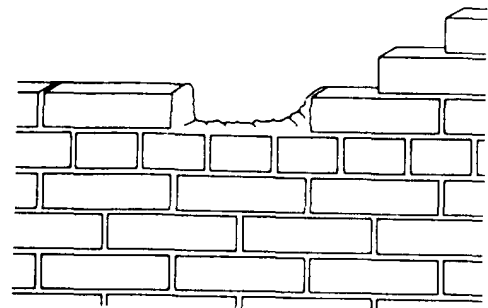

**1. Spreading Mortar on Ends of Brick Already Laid**

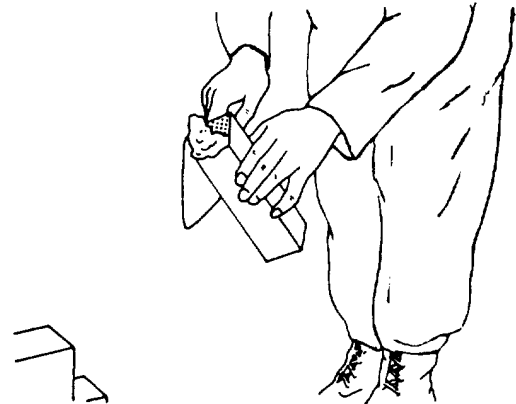

**2. Spreading Mortar on Both Ends of Closure Brick**

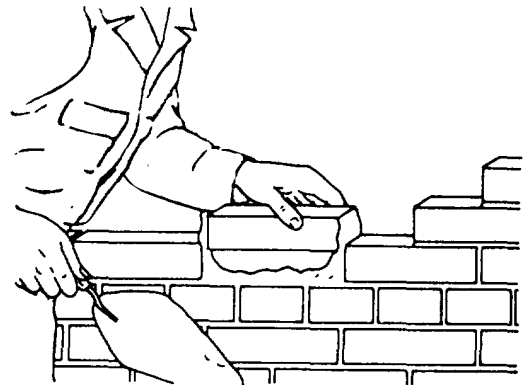

**3. Laying the Brick into Position**

Figure 8-44.-Making a closure joint in a stretcher course.

stretcher course (figure 8-44) using the same techniques as for a header course.

As we mentioned earlier, filling exposed joints with mortar immediately after laying a wall is called pointing. You can also fill holes and correct defective mortar joints by pointing, using a pointing trowel.

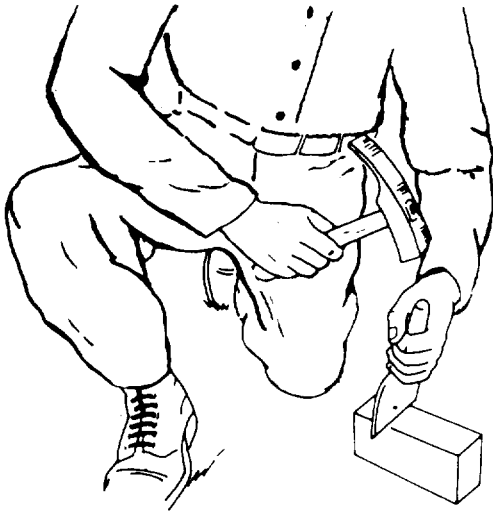

Figure 8-45.-Cutting brick with a chisel.

## CUTTING BRICK

To cut a brick to an exact line, you should use a chisel (figure 8-45), or brick set. The straight side of the tool's cutting edge should face both the part of the brick to be saved and the bricklayer. One mason's hammer blow should break the brick. For extremely hard brick, first roughly cut it using the brick hammer head, but leave enough brick to cut accurately with the brick set.

Use a brick hammer for normal cutting work, such as making the closure bricks and bats around wall openings or completing corners. Hold the brick firmly while cutting it. First, cut a line all the way around the brick using light hammer head blows. Then, a sharp blow to one side of the cutting line should split the brick at the cutting line (figure 8-46, view 1). Trim rough spots using the hammer blade, as shown in view 2.

## FINISHING JOINTS

The exterior surfaces of mortar joints are finished to make brick masonry waterproof and give it a better appearance. If joints are simply cut to the face of the brick and not finished, shallow cracks will develop immediately between the brick and the mortar. Always finish a mortar joint before the mortar hardens too much. Figure 8-47 shows several types of joint finishes, the more important of which are concave, flush, and weather.

Of all joints, the concave is the most weather tight. After removing the excess mortar with a trowel,

make this joint using a jointer that is slightly larger than the joint. Use force against the tool to press the mortar tight against the brick on both sides of the mortar joint.

The flush joint is made by holding the trowel almost parallel to the face of the wall while drawing its point along the joint.

A weather joint sheds water from a wall surface more easily. To make it, simply push downward on the mortar with the top edge of the trowel.

## ARCHES

A well-constructed brick arch can support a heavy load, mainly due to the way weight is distributed over its curved shape. Figure 8-48 shows two common arch shapes: elliptical and circular. Brick arches require full mortar joints. The joint width is narrower

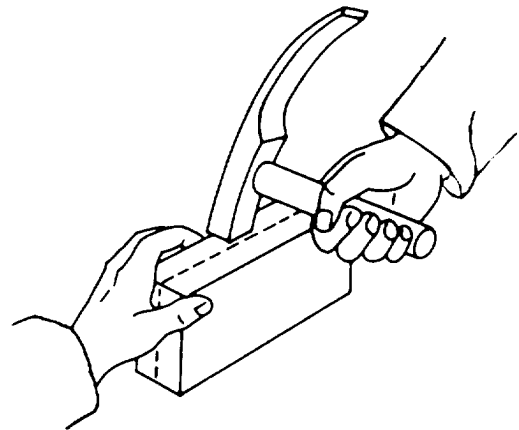

1. Striking Brick to One Side of Cutting Line

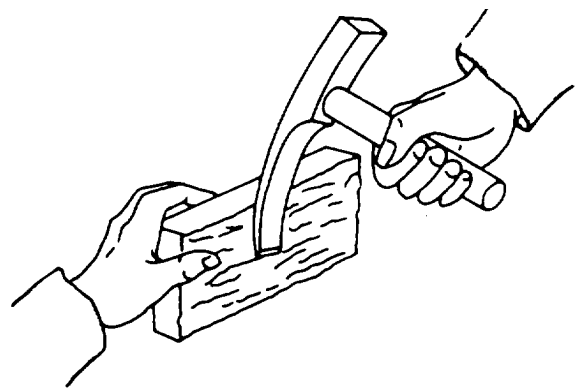

2. Trimming Rough Spots

Figure 8-46.-Cutting brick with a hammer.



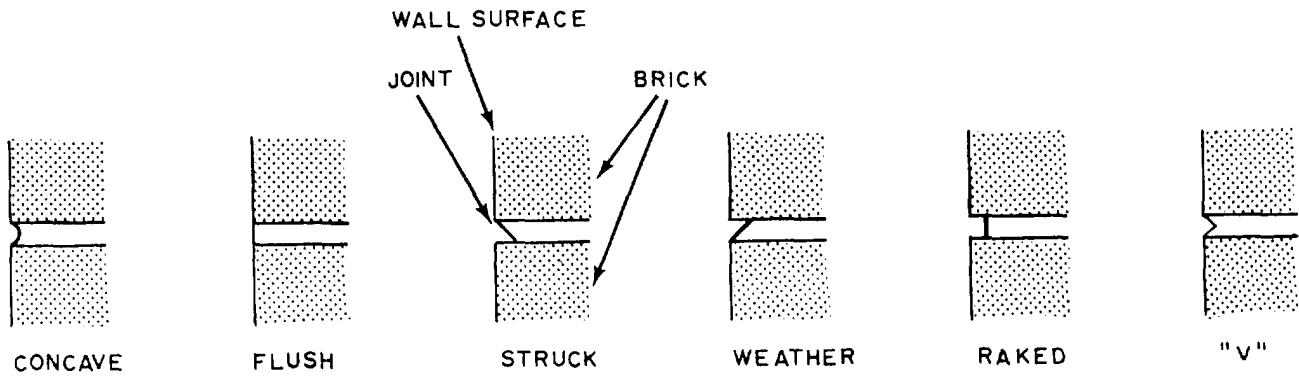

Figure 8-47.-Joint finishes.

at the bottom of the arch than at its top, but it should not narrow to less than 1/4 inch at any point. As laying progresses, make sure the arch does not bulge out of position.

**Templet**

It is obviously impossible to construct an arch without support from underneath. These temporary wooden supports must not only be able to support the masonry during construction but also provide the geometry necessary for the proper construction and appearance of the arch. Such supports are called templets.

**DIMENSIONS.**— Construct a brick arch over the templet (figure 8-49) that remains in place until the

mortar sets. You can obtain the templet dimensions from the construction drawings. For arches spanning up to 6 feet, use 3/4-inch plywood to make the templet. Cut two pieces to the proper curvature, and nail them to 2-by-4 spacers that provide a surface wide enough to support the brick.

**POSITIONING.**— Use wedges to hold the templet in position until the mortar hardens enough to make the arch self-supporting. Then drive out the wedges.

**Layout**

Lay out the arch carefully so that you don't have to cut any bricks. Use an odd number of bricks so that the key, or middle, brick falls into place at the exact arch center, or crown. The key, or middle, brick is the last one laid. To determine how many bricks an arch requires, lay the templet on its side on level ground and set a trial number of bricks around the curve. Adjust the number of bricks and the joint spacing (not less than 1/4-inch) until the key brick is at the exact center of the curve. Then, mark the positions of the bricks on the templet and use them as a guide when laying the brick.

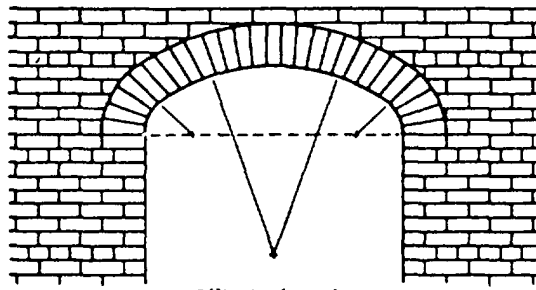

Elliptical Arch

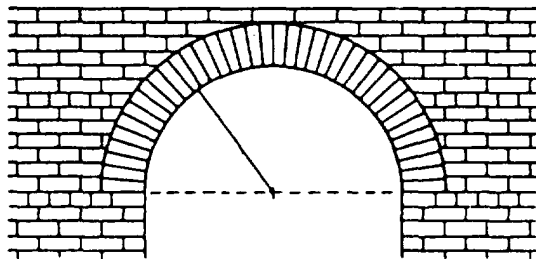

Circular Arch

Figure 8-48.-Common arch shapes.

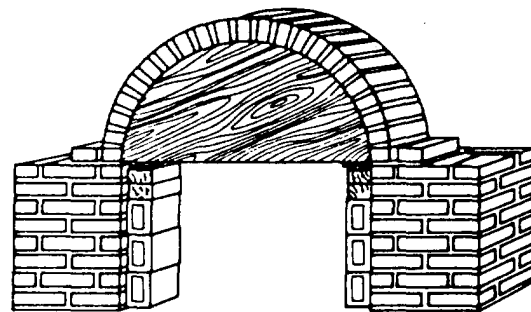

Figure 8-49.-Using a template to construct an arch.

## RECOMMENDED READING LIST

Although the following reference was current when this TRAMAN was published, its continued currency cannot be assured.

You therefore need to ensure that you are studying the latest revision.

*Concrete and Masonry*, FM 5-742, Headquarters, Department of the Army, Washington, D.C., 1985.

## CHAPTER 9

# PLANNING, ESTIMATING, AND SCHEDULING

Good construction planning and estimating procedures are essential for the Naval Construction Forces (NCFs) to provide quality construction response to the fleet's operational requirements. This chapter gives you helpful information for planning, estimating, and scheduling construction projects normally undertaken by Seabees. The material is designed to help you understand the concepts and principles involved; it is not intended to be a reference or to establish procedures. The techniques described are suggested methods that have been proved with use and can result in effective planning and estimating. It is your responsibility to decide how and when to apply these techniques.

Later in the chapter, you will encounter helpful tables to aid you in effective planning and estimating. Keep in mind that these tables are not intended to establish production standards. They should be used with sound judgment and in accordance with established regulations and project specifications. Man-hour tables are based upon direct labor and do not include allowances for indirect or overhead labor.

We provide helpful references at the end of the chapter. You are encouraged to study these, as required, for additional information on the topics discussed.

### DEFINITIONS

*LEARNING OBJECTIVE: Upon completing This section, you should be able to identify basic planning, estimating, and scheduling terms.*

In planning any project, you must be familiar with the vocabulary commonly associated with planning, estimating, and scheduling. Here, we'll define a number of terms you need to know as a Builder.

### PLANNING

Planning is the process of determining requirements, and devising and developing methods and action for constructing a project. Good construction planning is a combination of many elements: the

activity, material, equipment, and manpower estimates; project layout; project location; material delivery and storage; work schedules; quality control; special tools required; environmental protection; safety; and progress control. All of these elements depend upon each other. They must all be considered in any well-planned project.

### ESTIMATING

Estimating is the process of determining the amount and type of work to be performed and the quantities of material, equipment, and labor required. Lists of these quantities and types of work are called estimates.

### PRELIMINARY ESTIMATES

Preliminary estimates are made from limited information, such as the general description of projects or preliminary plans and specifications having little or no detail. Preliminary estimates are prepared to establish costs for the budget and to program general manpower requirements.

### DETAILED ESTIMATES

Detailed estimates are precise statements of quantities of material, equipment, and manpower required to construct a given project. Underestimating quantities can cause serious delays in construction and even result in unfinished projects. A detailed estimate must be accurate to the smallest detail to correctly quantify requirements.

### ACTIVITY ESTIMATES

An activity estimate is a listing of all the steps required to construct a given project, including specific descriptions as to the limits of each clearly definable quantity of work (activity). Activity quantities provide the basis for preparing the material, equipment, and manpower estimates. They are used to provide the basis for scheduling material deliveries, equipment, and manpower. Because activity estimates are used to prepare other estimates and

schedules, errors in these estimates can multiply many times. Be careful in their preparation!

## **MATERIAL ESTIMATES**

A material estimate consists of a listing and description of the various materials and the quantities required to construct a given project. Information for preparing material estimates is obtained from the activity estimates, drawings, and specifications. A material estimate is sometimes referred to as “a Bill of Material (BM)” or “a Material Takeoff (MTO) Sheet.” (We will discuss the BM and the MTO a little later in the chapter.)

## **EQUIPMENT ESTIMATES**

Equipment estimates are listings of the various types of equipment, the amount of time, and the number of pieces of equipment required to construct a given project. Information, such as that obtained from activity estimates, drawings, specifications, and an inspection of the site, provides the basis for preparing the equipment estimates.

## **MANPOWER ESTIMATES**

The manpower estimate consists of a listing of the number of direct labor man-days required to complete the various activities of a specific project. These estimates may show only the man-days for each activity, or they may be in sufficient detail to list the number of man-days for each rating in each activity—Builder (BU), Construction Electrician (CE), Equipment Operator (EO), Steelworker (SW), and Utilitiesman (UT). Man-day estimates are used in determining the number of personnel and the ratings required on a deployment. They also provide the basis for scheduling manpower in relation to construction progress.

When the *Seabee Planner's and Estimator's Handbook*, NAVFAC P-405, is used, a man-day is a unit of work performed by one person in one 8-hour day or its equivalent. One man-day is equivalent to a 10-hour day when the *Facilities Planning Guide*, NAVFAC P-437, is used.

Battalions set their own schedules, as needed, to complete their assigned tasks. In general, the work schedule of the battalion is based on an average of 55 hours per man per week. The duration of the workday is 10 hours per day, which starts and ends at the

jobsite. This includes 9 hours for direct labor and 1 hour for lunch.

Direct labor includes all labor expended directly on assigned construction tasks, either in the field or in the shop, that contributes directly to the completion of the end product. Direct labor must be reported separately for each assigned construction item. In addition to direct labor, the estimator must also consider overhead labor and indirect labor. Overhead labor is considered productive labor that does not contribute directly or indirectly to the product. It includes all labor that must be performed regardless of the assigned mission. Indirect labor includes labor required to support construction operations but does not, in itself, produce an end product.

## **ESTIMATOR**

An estimator is a person who evaluates the requirements of a task. A construction estimator must be able to mentally picture the separate operations of the job as the work progresses through the various stages of construction and be able to read and obtain accurate measurements from drawings. The estimator must have an understanding of math, previous construction experience, and a working knowledge of all branches of construction. The estimator must use good judgment when determining what effect numerous factors and conditions have on construction of the project and what allowances should be made for each of them. The estimator must be able to do careful and accurate work. A Seabee estimator must have ready access to information about the material, equipment, and labor required to perform various types of work under conditions encountered in Seabee deployments. The collection of such information on construction performance is part of estimating. Since this kind of reference information may change from time to time, information should be frequently reviewed.

## **SCHEDULING**

Scheduling is the process of determining when an action must be taken and when material, equipment, and manpower are required. There are four basic types of schedules: progress, material, equipment, and manpower.

Progress schedules coordinate all the projects of a Seabee deployment or all the activities of a single project. They show the sequence, the starting time, the performance time required, and the time required

for completion. Material schedules show when the material is needed on the job. They may also show the sequence in which materials should be delivered. Equipment schedules coordinate all the equipment to be used on a project. They also show when it is to be used and the amount of time each piece of equipment is required to perform the work. Manpower schedules coordinate the manpower requirements of a project and show the number of personnel required for each activity. In addition, the number of personnel of each rating (Builder, Construction Electrician, Equipment Operator, Steelworker, and Utilitiesman) required for each activity for each period of time may be shown. The time unit shown in a schedule should be some convenient interval, such as a day, a week, or a month.

### NETWORK ANALYSIS

Network analysis is a method of planning and controlling projects by recording their interdependence in diagram form. This enables you to undertake each problem separately. The diagram form, known as a network diagram, is drawn so that each job is represented by an activity on the diagram, as shown in figure 9-1. The direction in which the activities are linked indicates the dependencies of the jobs on each other.

### PROGRESS CONTROL

Progress control is the comparing of actual progress with scheduled progress and the steps necessary to correct deficiencies or to balance activities to meet overall objectives.

### PLANNING DOCUMENTATION

*LEARNING OBJECTIVE: Upon completing this section, you should be able to give the documentation requirements necessary in planning a construction project.*

There are two basic ground rules in analyzing a project. First, planning and scheduling are separate operations. Second, planning must always precede scheduling. If you don't plan sequentially, you will end up with steps out of sequence and may substantially delay the project. Everyone concerned should know precisely the following aspects of a project:

- What it is;
- Its start and finish points;
- Its external factors, such as the schedule dates and requirements of other trade groups;

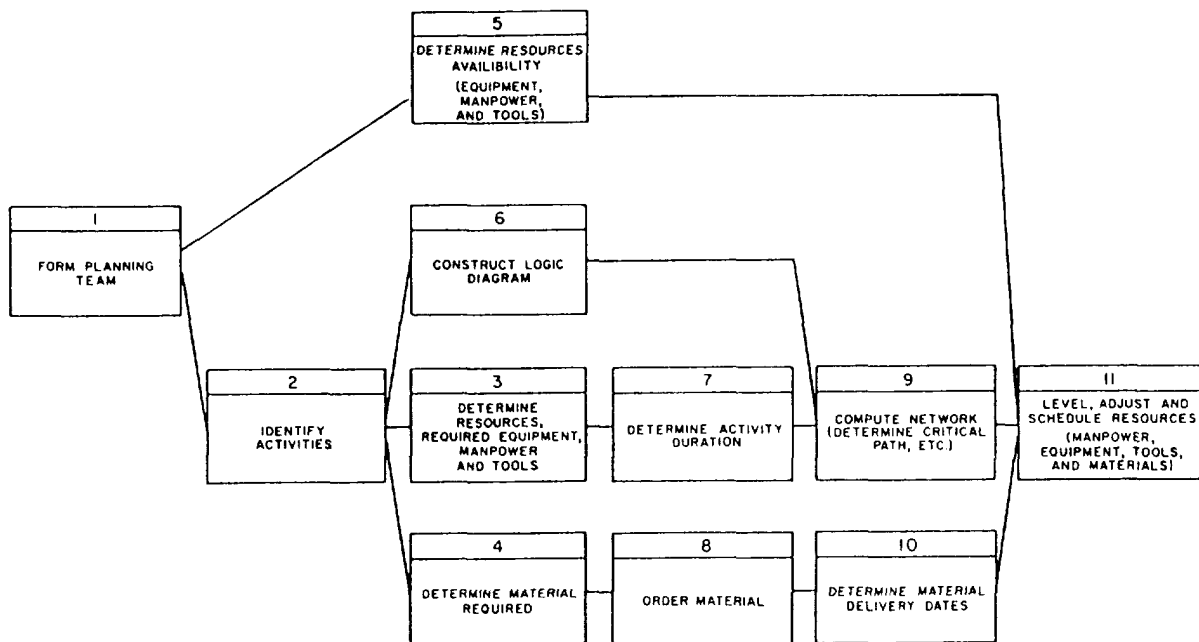

Figure 9-1.—Planning and estimating a precedence diagram.

- The availability of resources, such as manpower and equipment; and
- What you need to make up the project planning files.

## **PROJECT FOLDER**

The project folder, or package, consists of nine individual project files. These files not only represent the project in a paper format, but also give you, as the project crew leader, supervisor, or crewmember, exposure to the fundamentals of construction management.

### **File No. 1—General Information File**

File No. 1 is the General Information File and contains the following information:

**LEFT SIDE**— The left side of the General Information File basically contains information authorizing the project. The file should have the following items:

- Project scope sheet;
- Tasking letter;
- Project planning check list; and
- Project package sign-off sheet.

**RIGHT SIDE**— The right side of the General Information File contains basic information relating to coordinating the project. The file should have the following items:

- Project organization;
- Deployment calendar;
- Preconstruction conference notes; and
- Predeployment visit summary.

### **File No. 2—Correspondence File**

File No. 2 is the Correspondence File and consists of the following items:

**LEFT SIDE**— The left side contains outgoing messages and correspondence.

**RIGHT SIDE**— The right side of the file contains incoming messages and correspondence.

### **File No. 3—Activity File**

File No. 3, the Activity File, contains the following information:

**LEFT SIDE**— The left side contains the Construction Activity Summary Sheets of completed activities.

**RIGHT SIDE**— The right side of the file contains the following form sheets:

- Master activity sheets;
- Level II;
- Level II precedence diagram;
- Master activity summary sheets; and
- Construction activity summary sheets.

### **File No. 4—Network File**

File No. 4 is the Network File. It contains the following information:

**LEFT SIDE**— The left side contains the following documents:

- Computer printouts;
- Level III; and
- Level III precedence diagram.

**RIGHT SIDE**— The right side of the Network File contains the following items:

- Resource leveled plan for manpower and equipment; and
- Equipment requirement summary.

### **File No. 5—Material File**

File No. 5 is the Material File. It contains the following information:

**LEFT SIDE**— The left side contains the worksheets that you, as a project planner, must assemble. The list includes the following items:

- List of long lead items;
- 45-day material list;
- Material transfer list;
- Add-on/reorder justification forms;

- Bill of materials/material take-off comparison worksheets; and
- Material take-off worksheets.

**RIGHT SIDE**— The right side of the Material File contains the Bill of Materials (including all add-on/reorder BMs) supplied by the Naval Construction Regiment.

#### File No. 6—Quality Control File

File No. 6, the Quality Control File, contains the following information:

**LEFT SIDE**— The left side of this file contains various quality control forms and the field adjustment request.

**RIGHT SIDE**— The right side of the Quality Control File contains daily quality control inspection reports and your quality control plan.

#### File No. 7—Safety/Environmental File

File No. 7 is the Safety/Environmental File and consists of the following information:

**LEFT SIDE**— The left side of the Safety/Environmental File contains the following items:

- Required safety equipment;
- Stand-up safety lectures;
- Safety reports; and
- Accident reports.

**RIGHT SIDE**— The right side of the Safety/Environmental File contains the following:

- Safety plan, which you must develop;
- Highlighted EM 385; and
- Environmental plan (if applicable).

#### File No. 8-Plans File

File No. 8 is the Plans File and contains the following information:

**LEFT SIDE**— The left side contains the following planning documents:

- Site layout;
- Shop drawings;

- Detailed slab layout drawings (if applicable); and
- Rebar bending schedule.

**RIGHT SIDE**— The right side of the Plans File contains the actual project plans. Depending on thickness, plans should be either rolled or folded.

#### File No. 9—Specifications File

File No. 9 is the Specifications File; it contains the following information:

**LEFT SIDE**— The left side of this file is reserved for technical data.

**RIGHT SIDE**— The right side of the Specifications File has highlighted project specifications.

### ESTIMATING

*LEARNING OBJECTIVE: Upon completing this section, you should be able to explain the estimating requirements for a construction project.*

As project estimator, you will need to assemble information about various conditions affecting the construction of the project. This enables you to prepare a detailed and accurate estimate. Drawings should be detailed and complete. Specifications should be exact and leave no doubt as to their intent. Information should be available about local material, such as quarries, gravel pits, spoil areas, types of soil, haul roads and distances, foundation conditions, the weather expected during construction, and the time allotted for completion. You should know the number and types of construction equipment available for use. Consider all other items and conditions that might affect the production or the progress of construction.

### USING BLUEPRINTS

The construction drawings are your main basis for defining the required activities for measuring the quantities of material. Accurate estimating requires a thorough examination of the drawings. You should carefully read all notes and references and examine all details and reference drawings. The orientation of sectional views should be carefully checked. Dimensions shown on drawings or computed figures shown from those drawings should be used in preference to those obtained by scaling distances.

You should check the "Revision" section near the title section to ensure that the indicated changes were made in the drawing itself. You must ensure that the construction plan, the specifications, and the drawings are discussing the same project. When there are inconsistencies between general drawings and details, details should be followed unless they are obviously wrong. When there are inconsistencies between drawings and specifications, you should follow the specifications.

As an estimator, you must first study the specifications and then use them with the drawings when preparing quantity estimates. You should become thoroughly familiar with all the requirements stated in the specifications. Some estimators may have to read the specifications more than once to fix these requirements in their mind. You are encouraged to make notes as you read the specifications. These notes will be helpful to you later as you examine the drawings. In the notes, list any unusual or unfamiliar items of work or materials and reminders for use during examination of the drawings. A list of activities and materials that are described or mentioned in the specifications is helpful in checking quantity estimates.

The tables and diagrams in the *Seabee Planner's and Estimator's Handbook*, NAVFAC P-405, should save you time in preparing estimates and, when understood and used properly, provide accurate results. Whenever possible, the tables and the diagrams used were based on Seabee experience. Where suitable information was not available, construction experience was adjusted to represent production under the range of conditions encountered in Seabee construction. A thorough knowledge of the project drawings and specifications makes you alert to the various areas where errors may occur.

### **Accuracy as a Basis for Ordering and Scheduling**

Quantity estimates are used as a basis for purchasing materials, determining equipment, and determining manpower requirements. They are also used in scheduling progress, which provides the basis for scheduling material deliveries, equipment, and manpower. Accuracy in preparing quantity estimates is extremely important; these estimates have widespread uses and errors can be multiplied many times. Say, for example, a concrete slab is to measure 100 feet by 800 feet. If you misread the dimension for the 800-foot side as 300 feet, the computed area of the

slab will be 30,000 square feet, when it should actually be 80,000 square feet. Since area is the basis for ordering materials, there will be shortages. For example, concrete ingredients, lumber, reinforcing materials, and everything else involved in mixing and placing the concrete, including equipment time, manpower, and man-hours, will be seriously underestimated and ordered.

### **Checking Estimates**

The need for accuracy is vital, and quantity estimates should be checked to eliminate as many errors as possible. One of the best ways to check your quantity estimate is to have another person make an independent estimate and then to compare the two. Any differences should be checked to determine which is right. A less effective way of checking is for another person to take your quantity estimate and check all measurements, recordings, computations, extensions, and copy work, keeping in mind the most common error sources (listed in the next section).

### **Error Sources**

Failure to read **all** the notes on a drawing or failure to examine reference drawings results in many omissions. For example, you may overlook a note that states "symmetrical about the center line" and thus compute only half the required quantity.

Errors in scaling obviously mean erroneous quantities. Great care should be taken in scaling drawings so correct measurements are recorded. Common scaling errors include using the wrong scale, reading the wrong side of a scale, and failing to note that a detail being scaled is drawn to a scale different from that of the rest of the drawing. Remember: Some drawings are not drawn to scale. Since these cannot be scaled for dimensions, you must obtain dimensions from other sources.

Sometimes wrongly interpreting a section of the specifications causes errors in the estimate. If there is any doubt concerning the meaning of any part of the specification, you should request an explanation of that particular part.

Omissions are usually the result of careless examination of the drawings. Thoroughness in examining drawings and specifications usually eliminates errors of omission. Checklists should be used to assure that all activities or materials have been included in the estimate. If drawings are revised after material takeoff, new issues must be compared with



the copy used for takeoff and appropriate revisions made in the estimate.

Construction materials are subject to waste and loss through handling, cutting to fit, theft, normal breakage, and storage loss. Failure to make proper allowance for waste and loss results in erroneous estimates.

Other error sources are inadvertent figure transpositions, copying errors, and math errors.

## ACTIVITY ESTIMATES

The activity estimate provides a basis for preparing the estimates of material, equipment, and manpower requirements. An activity estimate, for example, might call for rough-in piping in a floor slab. In an activity estimate, your immediate concern is to identify the material necessary to do the task—pipe, fittings, joining materials, and so forth. The equipment estimate for this activity should consider vehicles for movement of material and special tools, such as portable power tools, a threader, and a power vise. From the scope of the activity and the time restraints, you can estimate the manpower required. The information shown in the activity estimate is also useful in scheduling progress and in providing the basis for scheduling deliveries of material, equipment, and manpower to the jobsite.

The techniques discussed in the next paragraphs will help you produce satisfactory activity estimates. But, before doing anything, you should become knowledgeable about the project by studying the drawings. Read the specifications and examine all available information concerning the site and local conditions. Only after becoming familiar with the project are you ready to identify individual activities. Now, here are two ideas that will help you make good estimates.

First, define activities. They may vary depending on the scope of the project. An activity is a clearly definable quantity of work. For estimating and scheduling, an activity for a single building or job should be a specific task or work element done by a single trade. For scheduling of large-scale projects, however, a complete building may be defined as an activity. But, for estimating it should remain at the single-task, single-trade level.

Second, after becoming familiar with the project and defining its scope, proceed with identifying the individual activities required to construct the project.

To identify activities, be sure each activity description shows a specific quantity of work with clear, definite limitations or cutoff points that can be readily understood by everyone concerned with the project. Prepare a list of these activities in a logical sequence to check for completeness.

## Material

Material estimates are used to procure construction material and to determine whether sufficient material is available to construct or complete a project. The sample forms shown in figures 9-2, 9-3, and 9-4 may be used in preparing material estimates. The forms show one method of recording the various steps taken in preparing a material estimate. Each step can readily be understood when the work sheets are reviewed. A work sheet must have the following headings: Project Title, Project Location, Drawing Number, Sheet Number, Project Section, Prepared By, Checked By, and Date Prepared.

**ESTIMATING WORK SHEET.**— The Estimating Work Sheet (figure 9-2), when completed, shows the various individual activities for a project with a listing of the required material. Material scheduled for several activities or uses is normally shown in the “Remarks” section. The work sheet should also contain an activity description, the item number, a material description, the cost, the unit of issue, the waste factors, the total quantities, and the remarks. The Estimating Work Sheets should be kept by the field supervisor during construction to ensure the use of the material as planned.

**MATERIAL TAKEOFF SHEET.**— The Material Takeoff Sheet (MTO) is shown in figure 9-3. In addition to containing some of the information on the Estimating Work Sheet, the MTO also contains the suggested vendors or sources, supply status, and the required delivery date.

**BILL OF MATERIAL.**— The Bill of Material (BM) sheet (figure 9-4) is similar in content to the Material Takeoff Sheet. Here, though, the information is presented in a format suitable for data processing. Use this form for requests of supply status, issue, or location of material, and for preparing purchase documents. When funding data is added, use these sheets for drawing against existing supply stocks.

Between procurement and final installation, construction material is subject to loss and waste.

ESTIMATING WORK SHEET												
PREPARED BY:		PROJ. LOCATION DIEGO GARCIA		SHEET 1 OF 5		DRAWING NO. 1,337,494/7.604.988		PROJ. TITLE CANTONMENT AREA INTERIM WATER SYSTEM BLDG.		DATE PREPARED 19 FEB '92		
CHECKED BY:		PROJ. SECTION ARCHITECTURAL		ACTIVITY NO. MODE 71 TO MODE 64		BM NO. DIW-112		MYO NO.				
ITEM NO.	DESCRIPTION	PREFAB FORMS	REFER TO SECT. V	DIW GC PAR	BIC	PP 71-8	BM NO.	BM LINE ITEM NO.	UNIT OF ISSUE	TOTAL QTY	REMARKS USE, LOC, PROCEDURES, ETC	
BUILDING FOOTING												
		L	W	T							SLAB/FOOTING	
		26'-8"	20'-0"	12"							EDGE FORMS - TO BE	
1.	3/4" PLYWOOD BB EXTERIOR TYPE 4' x 8'	2 (26'-8") x (20'-0") = 53'-8" x 40' = 93'-4"						1	SH	0	3	USED AT TRANSMITTER SITE BLDG.
		8' x 4' PLYWOOD RIPPED 12" x 32"										
		98.33/32' = 3 SHEETS										
2.	LUMBER 1x6xRL GR 2 OR BETTER	6 LENGTH x 2 EA. CORNER x 4 CORNERS = 8 PCS / 6 LONG						2	BF	15	30	BLDG LAYOUT BATTER BOARDS
3.	LUMBER 2x4xRL	16' - 48 PCS - 16' x 2 x 4 x 48 PCS						3	BF	15	590	USE REUSABLE 2x4 AT TRANSMITTER SITE BUILDING
RAMP AND DOOR STOOP FORMS												
4.	3/4" PLYWOOD 4' x 8'	(13'-8") + 2(6') + 3(4') = 37'-8"						1	SH	0	1	EDGE FORMS REUSE AT TRANSMITTER SITE BUILDING
		RP PLYWOOD INTO 8" STRIPS = 6 x 8 = 48										
BEAMS												
	B-1	2 EACH 26'-8" BOND BEAMS										
5.	3/4" PLYWOOD GR BB EXT TYPE 4' x 8'	26'-8" x 4 SIDES = 106'-8"						1	SH	0	10	B-1 SIDE FORMS REUSE AT TRANSMITTER SITE BUILDING

Figure 9-2.-Typical Estimating Work Sheet

MATERIAL TAKEOFF SHEET											
MATERIAL COST		SECTION 1: 1938.97		CANTONMENT AREA, INTERIM WATER SYS BLDG ARCHITECTURAL		DIEGO GARCIA		19 FEB '92		1,337,494/7.604.988	
P96		2 N		62583		4081 N Y		TW112		A TN W 2M9 05 4K6404	
LINE NO.	ITEM	QTY	UNIT	PRICE	TOTAL	DESCRIPTION	REMARKS	ESTIMATOR	CHECKER	DATE	SCALE
1	AOE	5H		697.903	094	1200	PLYWOOD, 3/4" BB EXTERIOR TYPE, SUGGESTED VENDOR: TWO HPSOM LBR CO				
2		BF		307.904	18	540	LUMBER, SOFTWOOD, 1 1/2" x 6" STANDARD CONSTRUCTION GRADE, 2 OR BETTER, SUGGESTED VENDOR: THOMPSON LBR CO				
3		BF		2422.7905	26	6718	LUMBER, SOFTWOOD, 2" x 4" x 16' STANDARD CONSTRUCTION GRADE, 2 OR BETTER, SUGGESTED VENDOR: THOMPSON LBR CO				
4		BF		1447.906	20	4032	LUMBER, SOFTWOOD, 2" x 6" x 16' STANDARD CONSTRUCTION GRADE, 2 OR BETTER, SUGGESTED VENDOR: THOMPSON LBR CO				
5		BF		1173.7907	33	3870	LUMBER, SOFTWOOD, 4" x 4" x 16' STANDARD CONSTRUCTION GRADE, 2 OR BETTER, SUGGESTED VENDOR: THOMPSON LUMBER CO				

Figure 9-3.-Typical Material Takeoff (MTO) Sheet.

BILL OF MATERIAL										SHIP APRIL '92		
FORM 436-01172 (REV. 3-77)										INTERIM WATER SYSTEM REINDEER STATION (CANTONMENT AREA)		
JOB ORDER										L.W. 112		
UNIT	QTY	SECT	SECT	SECT	SECT	SECT	SECT	SECT	SECT	SECT	SECT	SECT
IDENT	1 SC	STOCK NUMBER	QUANTITY	DOCUMENT NUMBER	DATE	REVISED	COC	ADJ	UNIT	TOTAL	DATE	DATE
IDENT	1 SC	STOCK NUMBER	QUANTITY	DOCUMENT NUMBER	DATE	REVISED	COC	ADJ	UNIT	TOTAL	DATE	DATE
APR		SH 69	40817903						1	PLYWOOD, 3/4" X 4' X 8' BB EXTERIOR	12.00	620.00
										TYPE SUGGESTED VENDOR:		
										THOMPSON LUMBER CO.		
		BF 50	7904						2	LUMBER, SOFTWOOD, 1" X 6" X 12'	10	9.40
										STANDARD CONSTRUCTION GRADE 2		
										OR BETTER. SUGGESTED VENDOR:		
										THOMPSON LUMBER CO.		
		BF 224E	7907						3	LUMBER, SOFTWOOD, 2" X 4' X 16'	20	627.76
										STANDARD CONSTRUCTION GRADE 2		
										OR BETTER. SUGGESTED VENDOR:		
										THOMPSON LUMBER CO.		
		BF 144	7906						4	LUMBER, SOFTWOOD, 2" X 6" X 16'	20	40.32
										STANDARD CONSTRUCTION GRADE 2		
										OR BETTER. SUGGESTED VENDOR:		
										THOMPSON LUMBER CO.		
DATE: 3-29-92										1101.48		
BY: J. B. JASON										L.W. 112		
BY: T. J. ABRATHY										L.W. 112		

Figure 9-4.-Sample Bill of Material (BM) sheet.

This loss may occur during shipping, handling, storage, or from the weather. Waste is inevitable where material is subject to cutting or final fitting before installation. Frequently, material, such as lumber, conduit, or pipe, has a standard issue length longer than required. More often than not, however, the excess is too short for use and ends up as waste. Waste and loss factors vary depending on the individual item and should be checked against the conversion and waste factors found in NAVFAC P-405, appendix C.

**CHECKLISTS.**— Use checklists to eliminate any omissions from the material estimates. Prepare a list for each individual project when you examine the drawings, specifications, and activity estimates. This is the practical way to prepare a listing for the variety of material used in a project. The listing applies only to the project for which it has been prepared. If no mistakes or omissions have been made in either the checklist or estimate, the material estimate will contain a quantity for each item on the list.

**LONG LEAD TIMES.**— Long lead items are not readily available through the normal supply system. They require your special attention to ensure timely delivery. Items requiring a long lead time are

nonsheff items, such as steam boilers, special door and window frames, items larger than the standard issue, and electrical transformers for power distribution systems. Identify and order these items early. Make periodic status checks of the orders to avoid delays in completing the project.

**PREPARING MATERIAL ESTIMATES.**— There are several steps for preparing a material estimate. First, determine the activity by using the activity description with the detailed information furnished by the drawings and plans to provide a quantity of work. Convert this quantity to the material required. Next, enter the conversion on a work sheet to show how each quantity was computed, as shown in figure 9-2. Include sufficient detail; work sheets need to be self-explanatory. Anyone examining them should be able to determine how the quantities were computed without having to consult the estimator. Allowances for waste and loss are added after determining the total requirement. All computations should appear on the estimate work sheet, as must all notes relative to the reuse of the material. Material quantities for similar items of a project are entered on the Material Takeoff Sheet or

Bill of Material. Figures 9-3 and 9-4 become the material estimate for the project.

### Equipment

Equipment estimates are used with production schedules to determine the construction equipment requirements and constraints for Seabee deployment. Of these constraints, the movement of material over roadways is frequently miscalculated. In the past, estimators used the posted speed limit as an average rate for moving material. This was wrong. Equipment speed usually averages between 40 to 56

percent of the posted speed limit. Factors, such as the road conditions, the number of intersections, the amount of traffic, and the hauling distances, vary the percentage of the posted speed limit. You should consider the types of material hauled; damp sand or loam, for example, is much easier to handle than clay. Safety (machine limitations), operator experience, condition of the equipment, work hours, and the local climate are other factors.

Equipment production must be determined so that the amount and type of equipment can be selected. Equipment production rates are available in the

SHEET <u>1</u> OF <u>2</u>	
ESTIMATED BY <u>Brown</u>	DATE <u>6/13/92</u>
CHECKED BY <u>Green</u>	DATE <u>6/23/92</u>
<b>EQUIPMENT ESTIMATE</b>	
NMCB _____	LOCATION <u>GUAM</u> YEAR <u>1992</u>
PROJECT <u>No. 013</u>	DESCRIPTION <u>Site Preparation</u>
<p>Earth Fill — 36,000 CY loose measurement required.          Haul one way 2-1/2 miles.          Use 2-1/2 CY endloader and 10 CY dump trucks.</p> <p>Endloader capacity 100 CY/hours.</p> <p><math>\frac{36,000}{100} = 360</math> hours or 45 eight-hour days.</p> <p><math>\frac{100}{10} = 10</math> trucks loaded per hour.</p> <p>Average hauling speed estimated at 15 MPH.</p> <p><math>2 \times 2.5 = 5</math> miles round trip.</p> <p><math>5/15 \times 60 = 20</math> minutes hauling time.</p> <p><math>60/10 = 6</math> minutes loading time.</p> <p>Estimated 4 minutes dumping time.</p> <p>30 minutes total time per truckload.</p> <p><math>60/30 = 2</math> loads per hour per truck.</p> <p><math>10/2 = 5</math> trucks required to keep endloader working at capacity.</p> <p><math>100 \times 8 = 800</math> CY hauled per 8-hour day.</p> <p>Need one bulldozer (can spread 1400 CY daily).</p> <p>Need one grader to keep haul road in shape.</p> <ul style="list-style-type: none"> <li>1 bulldozer (can spread 1400 CY daily).</li> <li>1 tractor &amp; tandem sheepfoot roller (can compact 1200 CY daily).</li> <li>1 water truck with sprinkler for moisture control.</li> <li>1 rubber-tired wobbly wheel roller on standby for compaction and sealing fill when rain is expected. (Can be towed by above bulldozer or tractor.)</li> </ul>	

Figure 9-5.-Sample equipment estimate (sheet 1 of 2).

*Seabee Planner's and Estimator's Handbook.* The tables in this handbook provide information about the type of equipment required. Estimate the production rate per day for each piece of equipment, You should consider the factors discussed above, along with information obtained from NAVFAC P-405 and your experience. The quantity of work divided by the production rate per day produces the number of days required to perform the project. After determining the number of days of required equipment operation, consult the project schedule to find the time allotted to complete the activities. Prepare the schedule for the total deployment. Use the project schedule to

determine when the work will be performed. The schedule should also indicate peak usage. It may have to be revised for more even distribution of equipment loading, thereby reducing the amount of equipment required during the deployment.

**ESTIMATE SHEETS.**— After the reviews and revisions, prepare a list of equipment required. The list must include anticipated downtime. Sufficient reserve pieces must be added to cover any downtime.

To aid you in preparing the equipment estimate schedule, use such forms as those shown in figures 9-5 and 9-6. The important information on the forms

SHEET <u>2</u> OF <u>2</u>			
ESTIMATED BY <u>Brown</u>		DATE <u>6/13/92</u>	
CHECKED BY <u>Green</u>		DATE <u>6/23/92</u>	
<b>EQUIPMENT ESTIMATE</b>			
NMCB _____	LOCATION <u>GUAM</u>	YEAR <u>1992</u>	
PROJECT <u>No. 013</u>	DESCRIPTION <u>Site Preparation</u>		
<p>NOTE: Preceding is not very efficient, as spreading equipment is not used to full capacity. Suppose that when the work schedule is prepared, completion of fill will be required in 18 days. Assume that climate is such that 3 days in every 17 working days will be lost due to rain. Therefore, 15 working days would be available in an 18 day schedule.</p> <p>3,600/15 = 2,400 cu. yd. must be hauled daily to complete the work on schedule.</p> <p>2,400/800 = 3 times the output of loading and hauling spread shown previously.</p> <p>Equipment required for loading and hauling:</p> <ul style="list-style-type: none"> <li>3 — 2-1/2 cu.yd. endloaders.</li> <li>1 — bulldozer to keep pit in shape.</li> <li>1 — grader to keep haul road in shape.</li> <li>15 — 10-ton trucks hauling (1 or 2 extra trucks should be added to assure that a truck will always be waiting to be loaded so that endloader will work at full capacity).</li> </ul> <p>2,400 cu. yd. will be hauled each day.</p> <p>2,400/1,200 = 2 tractors and tandem sheepfoot roller for compaction. 2 bulldozers to spread earth.</p> <p>2,400/1,400 = 1 water truck with sprinkler.</p> <p>1 wobbly-wheel roller (standby for sealing of fill before rains).</p> <p>NOTE: This is a more efficient operation, as production has been tripled but equipment has not, and total equipment working at or as close to capacity as can be expected.</p>			

Figure 9-6.-Sample equipment estimate (sheet 2 of 2).

includes the sheet number, the name of the estimator, the name of the checker, date checked, battalion and detachment number, location of deployment, year of deployment, project number, and a brief description of the project.

**TOA AND EQUIPMENT CHARACTERISTICS.**— The table of allowance (TOA) of the Naval Mobile Construction Battalion (NMCB) contains specific information on the quantities and

characteristics of construction equipment available to the NMCBs. Table 9-1 contains an abbreviated listing of such equipment.

**Labor**

There are two types of labor estimates: preliminary manpower estimates and detailed manpower estimates.

Table 9-1.-NMCB Construction Equipment Characteristics

QUANTITY	EQUIPMENT DESCRIPTION
12 8	<b>TRUCKS</b> Dump, 6 × 6, 5 ton, 5 cu. yd. capacity Dump, 6 × 4, 15 ton, 10 cu. yd. capacity
6	<b>GRADERS</b> Motor, road, 12 ft. blade, 6 × 4, with scarifier
4 2 2	<b>LOADERS</b> Scoop, full tracked, 2 1/2 cu. yd. multipurpose bucket Scoop, wheeled, 4 × 4, 2 1/2 cu. yd. std. bucket with forks Scoop, wheeled, 4 × 2, 2 1/2 cu. yd. std. bucket with forks backhoe, crane, dozer blade
2 3	<b>ROLLERS</b> Oscillating, self-propelled, 9 wheel, pneumatic tired Vibrating, self-propelled, pneumatic tired, single drum
6	<b>SCRAPERS</b> Tractor, wheeled, 14 to 20 cu. yd., hydraulic
5 2 1	<b>TRACTORS</b> Crawler, hydraulic semi-U-tilt dozer Crawler, hydraulic angle dozer, winch Crawler, hydraulic semi-U dozer, hydraulic ripper
2 1 1	<b>CRANES</b> Truck, mounted, 8 × 4, 35 ton, 60-ft. boom with extension Truck, mounted, 8 × 4, 25 ton, hydraulic Tractor, wheel mounted, 4 × 4, 12 1/2 ton, telescoping boom, hydraulic
1 2 2 2 2 2 8	<b>SPECIALIZED EQUIPMENT</b> Distributor, bituminous material, truck mounted, 6 × 4, 2,000 gal. capacity Distributor, water, truck mounted, 6 × 6, 2,000 gal. capacity Distributor, water, wagon mounted, 8,000 gal. capacity Ditching machine, ladder type, 8- to 24-in. width by 7-ft. depth, crawler mounted Excavator, multipurpose, hydraulic, 6 × 6, 11 ft. 1 in digging depth, truck mounted Auger, earth, truck mounted Truck, forklift, rough terrain, 6,000-lb. capacity, pneumatic tired

**PRELIMINARY.**— Use preliminary manpower estimates to establish budget costs and to project manpower requirements for succeeding projects and deployments. The estimates are prepared from limited information, such as general descriptions or preliminary plans and specifications that contain little or no detailed information. In some cases, you can make a comparison with similar facilities of the same basic design, size, and type of construction. A good preliminary estimate varies less than 15 percent from the detailed estimate.

**DETAILED.**— Use detailed manpower estimates to determine the manpower requirements for constructing a given project and the total direct labor requirements of a deployment. Take the individual

activity quantities from the activity work sheet to prepare detailed estimates. Then, select the man-hours per unit figure from the appropriate table in NAVFAC P-405 and multiply it by the quantity to obtain the total man-hours required. When preparing the activity estimates in the format discussed earlier, you may use a copy of the activity estimates as a manpower estimate work sheet by adding four columns to it with the headings of Activity, Quantity, Man-Hours Per Unit, and Total Man-Days Required. Work sheets, whether on the activity work sheet or on another format, should be prepared in sufficient detail to provide the degree of progress control desired. For example, the work sheets should show the following information:

DESCRIPTION	QUANTITY	MAN-HOURS* PER UNIT	TOTAL MAN-DAYS
Install 12-inch-diameter concrete pipe	2,500 feet	20/100	62.5
Install 30-inch-diameter concrete pipe	2,500 feet	80/100	250.0
<b>TOTALS</b>	5,000 feet		312.5
* 8 man-hours equals 1 man-day.			

If the control is to be exercised only on concrete pipe installation without regard to detail, the manpower estimate should show the following information on the summary sheet:

DESCRIPTION	QUANTITY	MAN-HOURS PER UNIT	TOTAL MAN-DAYS
Install concrete pipe	5,000 feet	50/100	312.5

Table 9-2.—Production Efficiency Guide Chart

ELEMENTS	LOW RODUCTION	AVERAGE PRODUCTION	HIGH PRODUCTION							
	Production Elements in Percent									
	25	35	45	55	65	75	85	90	95	100
<b>1. Work Load</b>	Construction requirement high, miscellaneous overhead high			Construction requirement normal, miscellaneous overhead normal				Construction requirement low, miscellaneous overhead low		
<b>2. Site Area</b>	Cramped working area, no area for material storage, work restricted to design, poor job layout			Work area limited slightly, partial material storage, some variation from design, average job layout				Large work area, adequate material storage, wide latitude from design, good job layout		
<b>3. Labor</b>	Poorly trained, low strength, low morale, high sick call			Average trained, normal strength, fair morale, normal sick call				Highly trained, over strength, high morale, low sick call		
<b>4. Supervision</b>	Poor management, poorly trained personnel, low strength			Average management, average trained personnel, normal strength				Efficient management, highly trained personnel, over strength		
<b>5. Job Conditions</b>	High quality work required, unfavorable site materials, short time operations, insect annoyance high			Average work required, average site materials, reasonable operation time, insect annoyance normal				Passable work required, good site materials, long time operation, no insect annoyance		
<b>6. Weather</b>	Abnormal rain, abnormal heat, abnormal cold			Moderate rain, moderate heat, moderate cold				Some rain, occasional heat, occasional cold		
<b>7. Equipment</b>	Improper job application, equipment in poor condition, repair and maintenance inadequate			Fair job application, equipment in average condition, repair and maintenance average				Efficient job application, equipment in good condition, efficient repair and maintenance		
<b>8. Tactical and Logistical</b>	Slow supply delivery, frequent tactical delays			Normal supply delivery, occasional tactical delays				Prompt supply delivery, no tactical delays		



The man-hours per unit on the work sheet is obtained by dividing the total man-days shown in the detail estimate by the total feet of concrete pipe times the unit to obtain the average man-hours. The man-hours per unit should be used for checking actual progress. You should check manpower estimates against the activity estimate to ensure that no activities have been omitted. NAVFAC P-405 provides labor estimates for the various projects undertaken by the Engineering Aids.

The *Facilities Planning Guide*, NAVFAC P-437, volumes 1 and 2, is an excellent source for preliminary estimates. Use it to find estimates for a wide range of facilities and assemblies commonly constructed. The P-437 not only gives the man-hours required, but it also gives a breakdown of the construction effort by ratings (BU, CE, UT, and so forth) as well as lapsed day estimates.

You must bear in mind that the lapse time from the P-437 is calculated using the contingency norm of a 10-hour man-day instead of the 8-hour man-day used in the P-405. For example, a specific task from the P-437 requires 100 man-hours (MH) of effort by the Utilitiesman. The optimum crew size is four UTs. This yields the following lapse time:

$$100 \frac{MH}{4 UTs \times 10 hr} = 2.5 \text{ days (lapse time)}$$

Using the P-405 and an 8-hour man-day, you will find that the same task yields the following:

$$100 \frac{MH}{4 UTs \times 8 hr} = 3.1 \text{ days (lapse time)}$$

In preparing manpower estimates, weigh the various factors affecting the amount of labor required to construct a project. These include weather conditions during the construction period, skill and experience of personnel who will perform the work, time allotted for completing the job, size of the crew to be used, accessibility of the site, and types of material and equipment to be used.

The production efficiency guide chart (table 9-2) lists eight elements that directly affect production. Each production element is matched with three areas for evaluation. Each element contains two or more foreseen conditions from which to select for the job in question. Evaluate each production element at some percentage between 25 and 100, according to your analysis of the foreseen conditions. The average of the eight evaluations is the overall production efficiency percentage. Now, convert the percentage

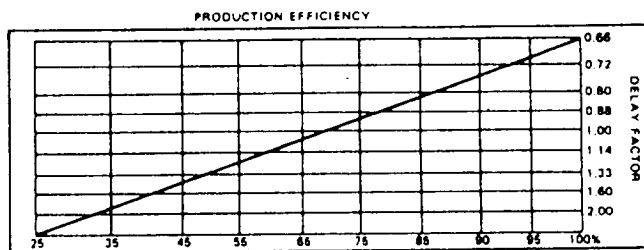

Figure 9-7.—Production efficiency graph.

to a delay factor, using the production efficiency graph (figure 9-7). It is strongly recommended that the field or project supervisors reevaluate the various production elements and make the necessary adjustments to man-day figures based on actual conditions at the jobsite.

#### NOTE

The estimate of average Seabee production used in the NAVFAC P-405 tables falls at 67-percent production efficiency on the graph shown in figure 9-7. As you see, this represents a delay factor of 1.00. A delay factor of 0.66 represents peak production efficiency, equivalent to 100 percent.

In reading the graph, note that the production elements have been computed into percentages of production efficiency, which are indicated at the bottom of the graph. First, place a straightedge so that it extends up vertically from the desired percentage, and then place it horizontally from the point at which it intersected the diagonal line. You can now read the delay factor from the values given on the right-hand side of the chart. Let's look at an example of the process of adjusting man-hour estimates.

Assume that from the work estimate taken from the tables in P-405, you find that 6 man-hours are needed for a given unit of work. To adjust this figure to the conditions evaluated on your job, assume that the average of foreseen conditions rated by you is 87 percent. The corresponding delay factor read from the production efficiency graph is 0.80. You find the adjusted man-hour estimate by multiplying this delay factor by the man-hours from the estimating tables ( $6MH \times 0.8 = 4.8$  as the adjusted man-hour estimate).

The man-hour labor estimating tables are arranged and grouped together into the 16 major divisions of work. This is the same system used to

prepare government construction specifications. The 16 major divisions of work are as follows:

1. General;
2. Site work;
3. Concrete;
4. Masonry;
5. Metal;
6. Carpentry;
7. Moisture protection;
8. Doors, windows, glass;
9. Finishes;
10. Specialties;
11. Architectural equipment;
12. Furnishings;
13. Special construction;
14. Conveying systems;
15. Mechanical; and
16. Electrical.

The activities in the various labor estimating tables are divided into units of measurement commonly associated with each craft and material takeoff quantities. There is only one amount of man-hour effort per unit of work. This number represents normal Seabee production under average conditions. As used herein, 1 man-day equals 8 man-hours of direct labor. Man-day figures do not include overhead items, such as dental or personnel visits, transportation to and from the jobsite, or inclement weather.

No two jobs are exactly alike, nor do they have exactly the same conditions. Therefore, you, as the estimator, must exercise some judgment about the project that is being planned. The production efficiency guide chart and graph (table 9-2 and figure 9-7) are provided to assist you in weighing the many factors that contribute to varying production conditions and the eventual completion of a project. You can then translate what is known about a particular project and produce a more accurate quantity from the average figures given on the labor estimating tables.

## SCHEDULING

*LEARNING OBJECTIVE: Upon completing this section, you should be able to explain the scheduling requirements for a construction project.*

After World War II, the construction industry experienced the same critical examination that the manufacturing industry had experienced 50 years before. Large construction projects came under the same pressures of time, resources, and cost that prompted studies in scientific management in the factories.

The emphasis, however, was not on actual building methods, but upon the management techniques of programming and scheduling. The only planning methods being used at that time were those developed for use in factories. Management tried to use these methods to control large construction projects. These techniques suffered from serious limitations in project work. The need to overcome these limitations led to the development of network analysis techniques.

### BASIC CONCEPTS

In the late 1950s, this new system of project planning, scheduling, and control came into widespread use in the construction industry. The critical path analysis (CPA), critical path method (CPM), and project evaluation and review technique (PERT) are samples of about 50 different approaches. The basis of each of these approaches is the analysis of a network of events and activities. For this reason, the generic title covering the various networks is "network analysis."

Network analysis techniques are now the accepted method of construction planning in many organizations. They form the core of project planning and control systems.

### Advantages and Disadvantages

There are many advantages of network analysis. As a management tool, it readily separates planning from scheduling of time. The analysis diagram, a pictorial representation of the project, enables you to see the interdependencies between events and the overall project to prevent unrealistic or superficial planning. Resource and time restraints are easily

detachable, to permit adjustments in the plan before its evaluation.

Because the system splits the project into individual events, estimates and lead times are more accurate. Deviations from the schedule are quickly noticed. Manpower, material, and equipment resources are easily identifiable. Since the network remains constant throughout its duration, it is also a statement of logic and policy. Modifications of the policy are allowed, and the impact on events is assessed quickly.

Identification of the critical path is useful when you have to advance the completion date. Attention can then be concentrated toward speeding up those relatively few critical events. The network allows you to accurately analyze critical events and provides an effective basis for the preparation of charts. This results in better control of the entire project.

The main disadvantage of network analysis as a planning tool is that it is a tedious and exacting task when attempted manually. Depending upon what the project manager wants as output, the number of activities that can be handled without a computer varies but is never high.

Calculations are in terms of the sequence of activities. Now, a project involving several hundred activities may be attempted manually. However, the chance for error is high. Suppose the jobs are to be sorted by rating, so jobs undertaken by Utilitiesmen are together as are those for Equipment Operators or Construction Electricians. The time required for manual operation would become costly.

On the other hand, standard computer programs for network analysis can handle project plans of 5,000 activities or more and can produce output in various forms. However, a computer assists only with the calculations and print plans of operations sorted into various orders. The project manager, not the computer, is responsible for planning and must make decisions based on information supplied by the computer. Also, computer output is only as accurate as its input, supplied by people. The phrase "garbage in, garbage out" applies.

## Elements

A network represents any sequencing of priorities among the activities that form a project. This sequencing is determined by hard or soft dependencies. Hard dependencies are based upon the

physical characteristics of the job, such as the necessity for placing a foundation before building the walls. A hard dependency is normally inflexible. Soft dependencies are based upon practical considerations of policy and may be changed if circumstances demand. The decision to start at the north end of a building rather than at the south end is an example.

## PRECEDENCE DIAGRAMING

Network procedures are based upon a system that identifies and schedules key events into precedence-related patterns. Since the events are interdependent, proper arrangement helps in monitoring the independent activities and in evaluating project progress. The basic concept is known as the critical path method (CPM). Because the CPM places great emphasis upon task accomplishment, a means of activity identification must be established to track the progress of an activity. The method currently in use is the activity-on-node precedence diagramming method (PDM), where a node is simply the graphic representation of an activity. An example of this is shown in figure 9-8.

Precedence diagramming does not require the use of dummy activities. It is also easier to draw, and has greater applications and advantages when networks are put in the computer. In precedence diagrams, the activity is "on the node."

### Activities and Events

To build a flexible CPM network, the manager needs a reliable means of obtaining project data to be represented by a node. An activity in a precedence diagram is represented by a rectangular box and identified by an activity number.

The left side of the activity box represents the start of the activity. The right side represents the

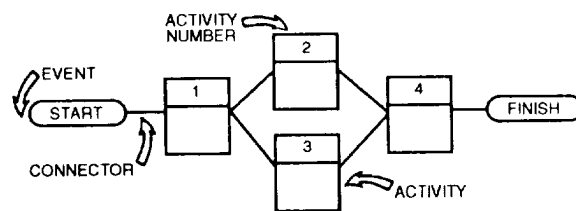

Figure 9-8.—Precedence diagram.

completion. Lines linking the boxes are called connectors. The general direction of flow is evident in the connectors themselves.

Activities may be divided into three distinct groups:

1. Working activities—Activities that relate to particular tasks;
2. Milestone events—Intermediate goals with no time duration, but that require completion of prior events before the project can proceed; and
3. Critical activities—Activities that, together, comprise the longest path through the network. This is represented by a heavy- or hash-marked line.

The activities are logically sequenced to show the activity flow for the project. The activity flow can be determined by answering the following questions: What activities must precede the activity being examined? What activities can be concurrent with this activity? What activities must follow this activity?

**WORKING ACTIVITIES.**— With respect to a given activity, these representations indicate points in time for the associated activities. Although the boxes in the precedence diagram represent activities, they do not represent time and, therefore, are not normally drawn to scale. They only reflect the logical sequence of events.

**MILESTONE EVENTS.**— The network may also contain certain precise, definable points in time, called events. Examples of events are the start and finish of the project as a whole. Events have no duration and are represented by oval boxes in a network, as shown in figure 9-8.

Milestones are intermediate goals within a network. For instance, “ready for print” is an important event that represents a point in time but has no time duration of its own. To reach this particular activity, all activities leading up to it must be completed.

**CRITICAL ACTIVITIES.**— A critical activity is an activity within the network that has zero float time. The critical activities of a network make up the longest path through the network (critical path) that controls the project finish date. Slashes drawn through an activity connector, as shown in figure 9-9, denote a critical path.

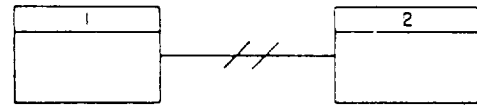

Figure 9-9.—Designations of a critical path.

The rule governing the drawing of a network is that the start of an activity must be linked to the ends of all completed activities before that start may take place. Activities taking place at the same time are not linked in any way. In figure 9-8, both Activity 2 and Activity 3 start as soon as Activity 1 is complete. Activity 4 requires the completion of both Activities 2 and 3 before it may start.

### Use of Diagram Connectors

Within a precedence diagram, connectors are lines drawn between two or more activities to establish logic sequence. In the next paragraphs, we will look at the diagram connectors commonly used in the NCFs.

**REPRESENTING A DELAY.**— In certain cases, there may be a delay between the start of one activity and the start of another. In this case, the delay may be indicated on the connector itself, preceded by the letter *d* as in figure 9-10. Here, Activity 2 may start as soon as Activity 1 is complete, but Activity 3 must wait 2 days. The delay is stated in the basic time units of the project, so the word “days” can be omitted.

**REPRESENTING A PARALLEL ACTIVITY.**— Some activities may parallel others. This can be achieved in precedence diagrams without increasing the number of activities. For instance, it is possible to start laying a long pipeline before the excavations are completed. This type of overlap is known as a lead. It is also possible to start a job independently, but to not complete it before another is

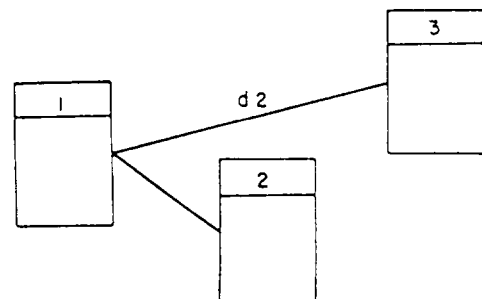

Figure 9-10.—Representation of delay.

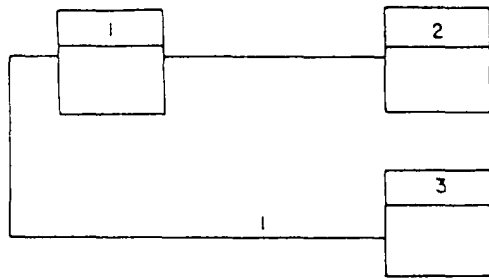

Figure 9-11.—Lead on start of a preceding activity.

completed. This type of overlap is known as a lag. It is also a common occurrence that both the start and the finish of two activities maybe linked, but, in this case, they are accommodated by a combination of lead and lag.

As seen in figure 9-11, a lead (or partial start) is indicated by drawing the connector from the start of the preceding activity (1). In figure 9-12, a lag (or partial finish) is indicated by drawing the connector from the end of the following activity (3). The values may be given in the basic time units of the project, as with a delay, or as a percentage of overlap. In certain circumstances, they can be stated as quantities if the performance of the activity can be measured on a quantitative basis. The indication of the type and amount of delay, lead, or lag is generally referred to as a "lag factor."

In figure 9-11, Activity 3 may start when Activity 1 is 1-day completed, although Activity 2 must wait for the final completion of Activity 1. In figure 9-12, Activity 3 may start when Activity 2 is completed but will still have 1 day to go when Activity 1 is completed. The last phase of Activity 3 may not begin until Activity 1 has been completed. In figure 9-13, Activity 2 may start when Activity 1 is

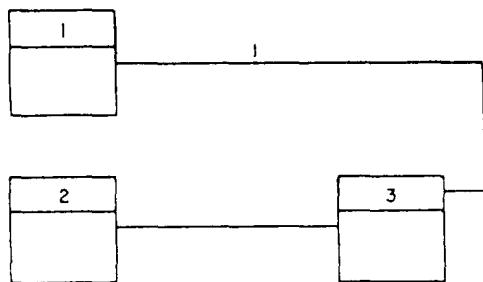

Figure 9-12.—Lag on finish a of following activity.

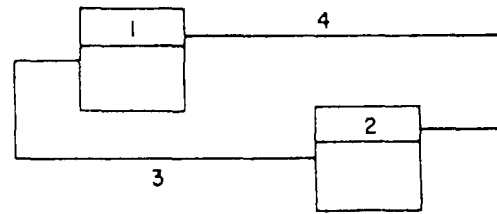

Figure 9-13.—Start and finish lags on same activity.

advanced 3 days but will still have 4 days of work left when Activity 1 is completed.

**SPLITTING CONNECTORS.**— The number of sequencing connectors becomes large when a net work is of a great size. When two activities are remote from each other and have to be connected, the lines tend to become lost or difficult to follow. In such cases, it is not necessary to draw a continuous line between the two activities. Their relationship is shown by circles with the following-activity number in one and the preceding-activity number in the other. In figure 9-14, both Activities 2 and 6 are dependent upon Activity 1.

**DIRECT LINKING USING AN EVENT.**— When the number of common preceding and succeeding activities in a particular complex is large, as in figure 9-15, a dummy event or focal activity of zero duration may be introduced to simplify the network. The use of such a dummy event is shown in figure 9-16, which is a simplification of figure 9-15. Although the effect in terms of scheduling is the same, the introduction of the dummy improves the clarity of the diagram.

**JOINING CONNECTORS.**— In many instances, there are opportunities to join several

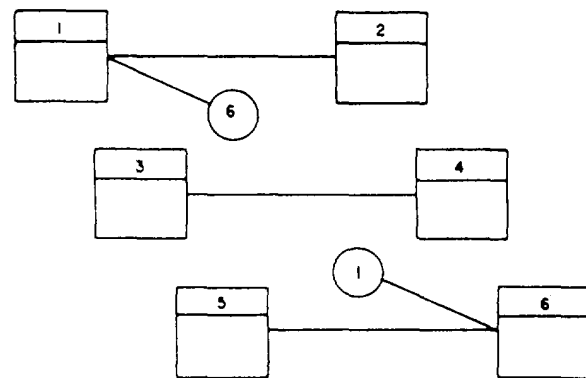

Figure 9-14.—Splitting connectors.

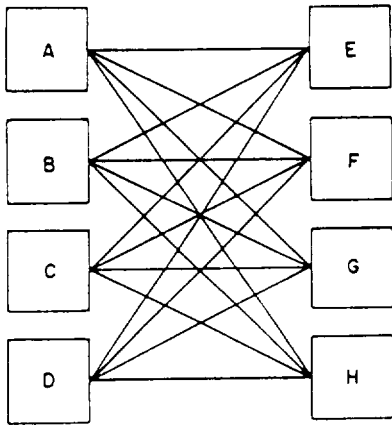

Figure 9-15.—Multiple predecessors and successors (direct linking).

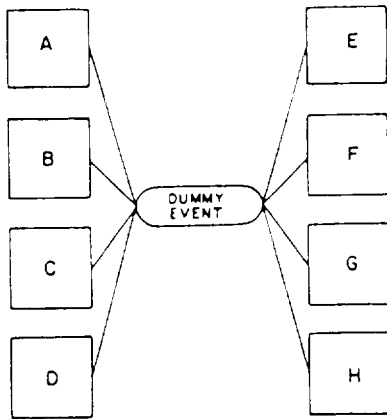

Figure 9-16.—Multiple predecessors and successors (using dummy collector).

connectors going to a common point to reduce congestion in the drawing. This practice is, however, discouraged.

The diagrams in figures 9-17 and 9-18 have precisely the same interpretation. The danger with

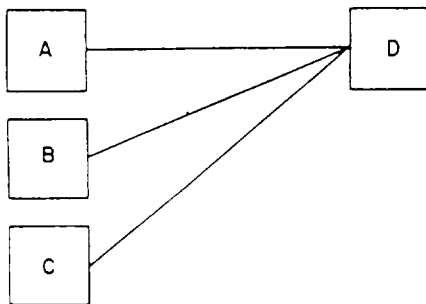

Figure 9-17.—Direct representation of dependencies.

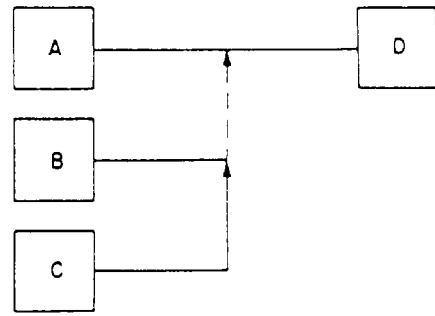

Figure 9-18.—Indirect linking of dependencies.

the form of representation is evident in figure 9-18, where several connectors have been joined. When the network is coded for the computer, you may lose sight of the fact that Activity D has three preceding activities since only one line actually enters Activity D.

### PRECEDENCE DIAGRAMS

Scheduling involves putting the network on a working timetable. Information relating to each activity is contained within an activity box, as shown in figure 9-19.

### Forward and Backward Pass Calculations

To place the network on a timetable, you must make time and duration computations for the entire project. These computations establish the critical path and provide the start and finish dates for each activity.

Each activity in the network can be associated with four time values:

- **Early start (ES)**— Earliest time an activity may be started;

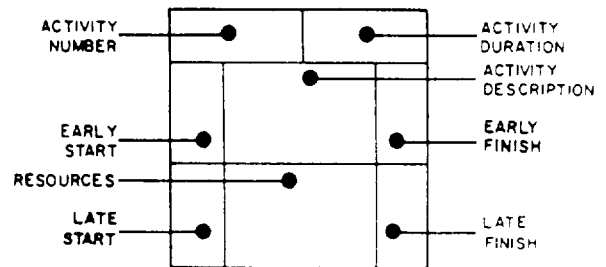

Figure 9-19.—Information for a precedence activity.

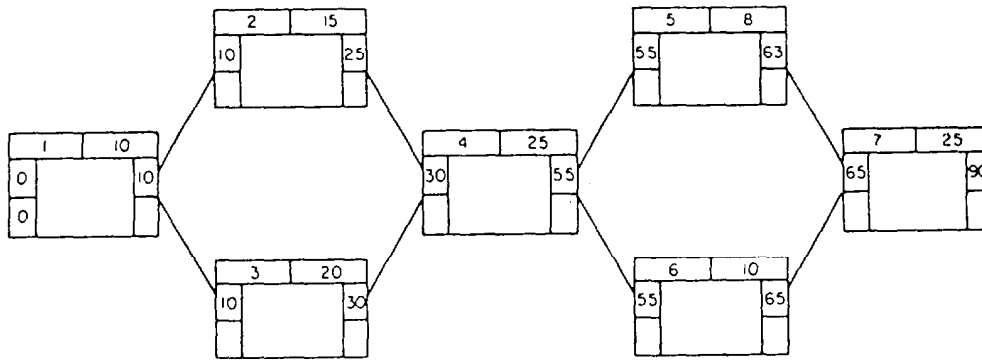

Figure 9-20.—Example of forward-pass calculations.

- **Early finish (EF)**— Earliest time an activity may be finished;
- **Late start (LS)**— Latest time an activity may be started and still remain on schedule; and
- **Late finish (LF)**— Latest time an activity may be finished and still remain on schedule.

The main objective of forward-pass computations is to determine the duration of the network. The forward pass establishes the early start and finish of each activity and determines the longest path through the network (critical path).

The common procedure for calculating the project duration is to add activity durations successively, as shown in figure 9-20, along chains of activities until a merge is found. At the merge, the largest sum entering the activity is taken at the start of succeeding activities. The addition continues to the next point of merger, and the step is repeated. The formula for forward-pass calculations is as follows:

$$ES = EF \text{ of preceding activity}$$

$$EF = ES + \text{activity duration}$$

The backward-pass computations provide the latest possible start and finish times that may take place without altering the network relationships. These values are obtained by starting the calculations at the last activity in the network and working backward, subtracting the succeeding duration of an activity from the early finish of the activity being calculated. When a “burst” of activities emanating from the same activity is encountered, each path is calculated. The smallest or multiple value is recorded as the late finish.

The backward pass is the opposite of the forward pass. During the forward pass, the early start is added to the activity duration to become the early finish of that activity. During the backward pass, the activity duration is subtracted from the late finish to provide the late start time of that activity. This late start time then becomes the late finish of the next activity within the backward flow of the diagram.

$$LS = LF - \text{activity duration}$$

Figure 9-21 shows a network with forward- and backward-pass calculations entered.

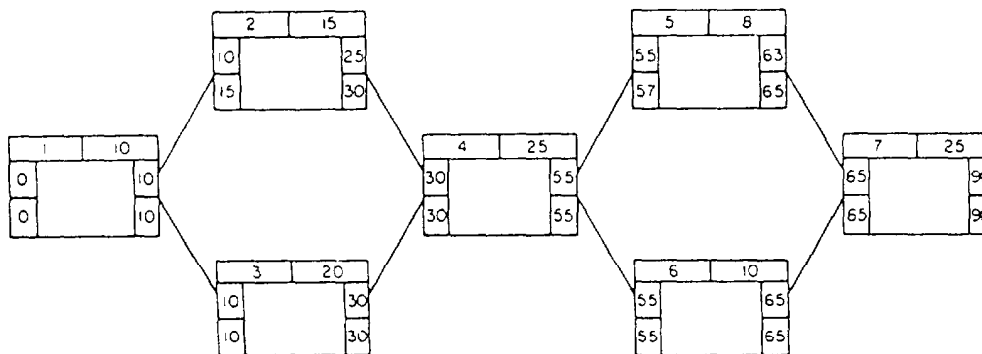
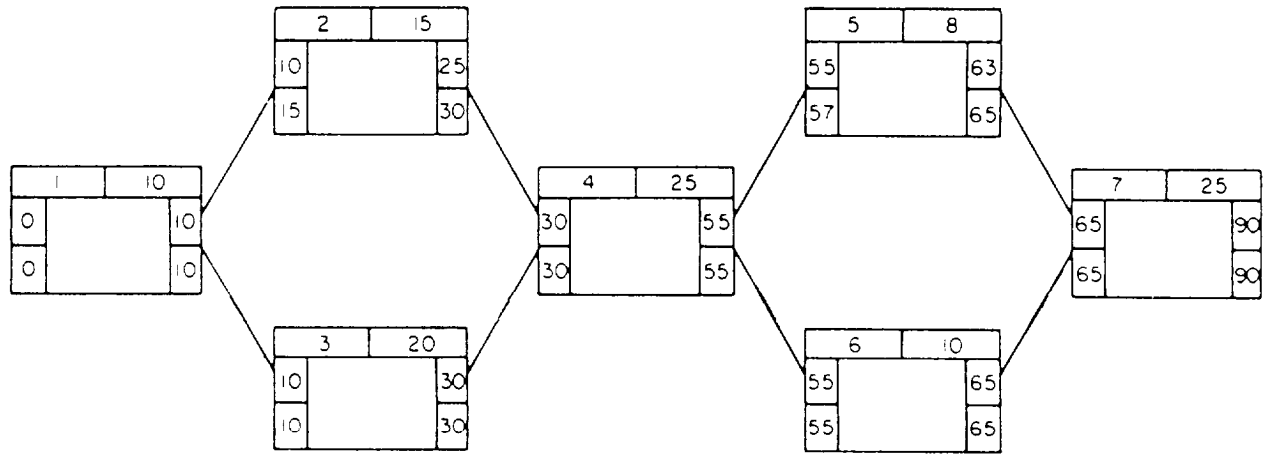

Figure 9-21.—Example of forward- and backward-pass calculations.



ACTIVITY	DUR	ES	EF	LS	LF	FF	TF	
1	10	0	10	0	10	0	0	CRITICAL
2	15	10	25	15	30	5	5	
3	20	10	30	10	30	0	0	CRITICAL
4	25	30	55	30	55	0	0	CRITICAL
5	8	55	63	57	65	2	2	
6	10	55	65	55	65	0	0	CRITICAL
7	25	65	90	65	90	0	0	CRITICAL

Figure 9-22.—PDM network with total and free float calculations.

The free and total float times are the amount of scheduled leeway allowed for a network activity, and are referred to as float or slack. For each activity, it is possible to calculate two float values from the results of the forward and backward passes.

**TOTAL FLOAT.**— The accumulative time span in which the completion of all activities may occur and not delay the termination date of the project is the total float. If the amount of total float is exceeded for any activity, the project end date extends to equal the exceeded amount of the total float.

Calculating the total float consists of subtracting the earliest finish (EF) date from the latest finish (LF) date, that is:

$$\text{Total float} = LF - EF$$

**FREE FLOAT.**— The time span in which the completion of an activity may occur and not delay the finish of the project or the start of a successor activity is the free float. If this value is exceeded, it may not affect the project end date but will affect the start of succeeding, dependent activities.

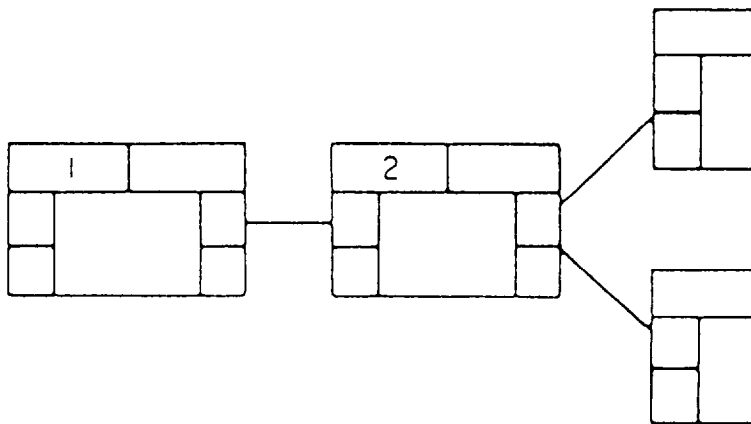

Figure 9-23.—Independent activity.



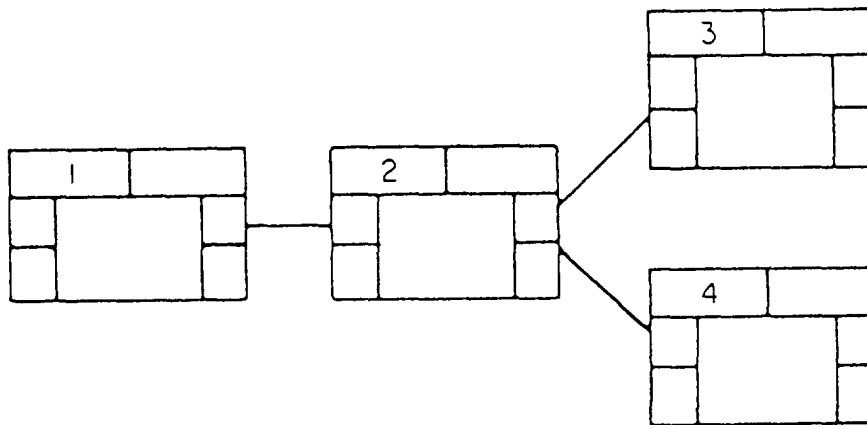

Figure 9-24.—Dependent activity.

Calculating the free float consists of subtracting the earliest start (ES) date from the latest start (LS) date, or:

$$\text{Free float} = \text{LS} - \text{ES}$$

Figure 9-22 is an example of an activity-on-node precedence diagramming method (PDM) network with total and free float calculations completed.

**INDEPENDENT ACTIVITY.**— An independent activity is an activity that is not dependent upon another activity to start. Activity 1, diagrammed in figure 9-23, is an example of an independent activity.

**DEPENDENT ACTIVITY.**— A dependent activity is an activity that is dependent upon one or more preceding activities being completed before it can start. The relationship in figure 9-24 states that the start of Activity 2 is dependent upon the finish of Activity 1.

Frequently, an activity cannot start until two or more activities have been completed. This appears in the diagram as a merge or junction. In figure 9-25, Activities 3 and 4 must be completed before the start of Activity 5.

Earlier we mentioned a “burst” of activities. A burst is similar to a merge. A burst exists when two or more activities cannot be started until a third activity is completed. In figure 9-24, when Activity 2 is finished, Activities 3 and 4 may start.

#### Advantages of Diagramming

Precedence networks are easy to draw because all the activities can be placed on small cards, laid out on a flat surface, and easily manipulated until a realistic logic is achieved. It is also easy to show the interrelationships and forward progress of the activities. Just

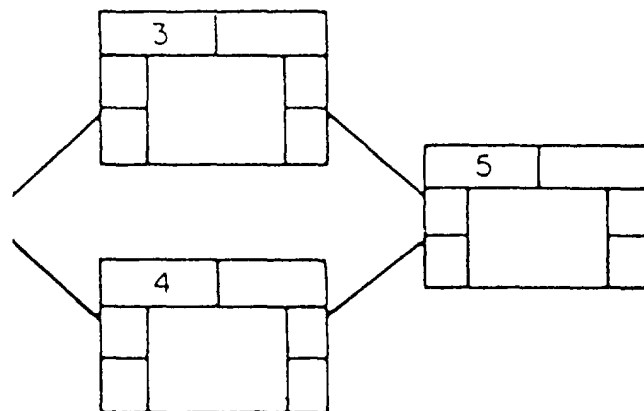
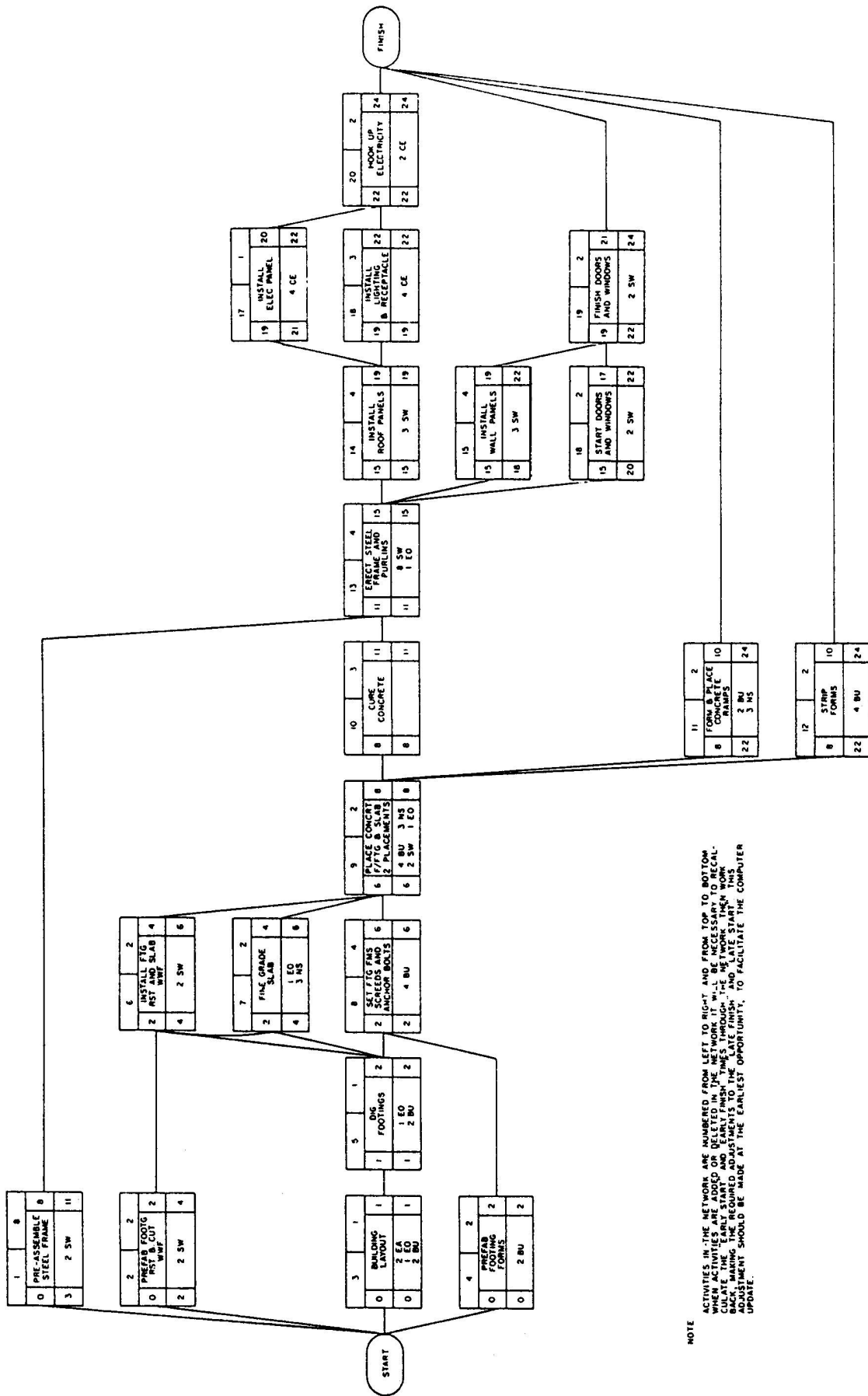

Figure 9-25.—Merge.



NOTE  
 ACTIVITIES IN THE NETWORK ARE NUMBERED FROM LEFT TO RIGHT AND FROM TOP TO BOTTOM. WHEN ACTIVITIES ARE ADDED OR DELETED IN THE NETWORK, IT WILL BE NECESSARY TO RECALCULATE THE LATE FINISH AND LATE START DATES FOR ALL ACTIVITIES. MAKE THE REQUIRED ADJUSTMENTS TO THE LATE FINISH AND LATE START DATES. MAKING THE REQUIRED ADJUSTMENTS TO THE LATE FINISH AND LATE START DATES SHOULD BE MADE AT THE EARLIEST OPPORTUNITY, TO FACILITATE THE COMPUTER UPDATE.

Figure 9-26.—Typical precedence diagram for a 40-by-100-foot rigid-frame building.

draw connector lines. Figure 9-26 shows a typical precedence diagram for a 40-by- 100-foot rigid-frame building.

### RECOMMENDED READING LIST

#### NOTE

Although the following references were current when this TRAMAN was published, their continued currency cannot be assured. You therefore need to ensure that you are studying the latest revision.

*Facilities Planning Guide*, NAVFAC P-437, Naval Facilities Engineering Command, Alexandria, Va., 1982.

*Operations Officer's Handbook*, COMCBPAC/COMCBLANTINST 5200.2A, Commander, Naval Construction Battalions, U.S. Pacific Fleet, Pearl Harbor, Hawaii, and Commander, Naval Construction Battalions, U.S. Atlantic Fleet, Norfolk, Va., 1988.

*Seabee Planner's and Estimator's Handbook*, NAVFAC P-405, Chapter 5, Naval Facilities Engineering Command, Alexandria, Va., 1983.



## APPENDIX I

# GLOSSARY

- AGGREGATE**—Crushed rock or gravel screened to size for use in road surfaces, concrete, or bituminous mixes.
- AIR-ENTRAINED CONCRETE**—Concrete containing millions of trapped air bubbles.
- AUGER**—A boring bit.
- BATCH**—The amount of concrete mixed at one time regardless of quantity.
- BATTER BOARDS**—Two boards nailed at right angles to posts set up near the proposed corner of an excavation for a building and used for transferring building lines.
- BOX NAILS**—Lightweight nails with large heads.
- BRAD**—A slender nail with a small head.
- BRICK**—Solid blocks of fine clay.
- BUTTERING**—Putting mortar on a brick or block with a trowel before laying.
- CARRIAGE BOLT**—A partially threaded bolt with a head that is flat on the underside and rounded on top.
- CASING NAILS**—Twopenny (2d) to forty penny (40d) nails with flaring heads.
- CEMENT**—Fuzed and pulverized limestone and clay.
- COMMON BOND**—Five stretcher courses with the sixth as an all header course.
- COMMON NAILS**—Twopenny (2d) to sixty penny (60d) strong nails.
- CONCRETE BUGGY**—Two-wheeled buggy for transporting concrete, nicknamed “Georgia Buggy.”
- CONCRETE**—Artificial stone made of cement, water, sand, and aggregate.
- CONSTRUCTION JOINT**—A joint that runs through concrete. Made by pouring sections of a structure at different times.
- COURSE**—A single layer of bricks, stone, or other masonry.
- CURING**—The process of keeping concrete damp and at favorable temperatures to ensure complete hardening.
- EXPANSION JOINT**—Construction joint with expandable material at the contact points.
- FINISHING NAILS**—Twopenny (2d) to twenty penny (20d) sizes with small barrel-shaped heads.
- FOOTING**—An enlargement at the lower end of a wall to distribute the load to a wider area of supporting soil.
- GIN POLE**—An upright guy pole with hoisting tackle and foot-mounted snatch block used for vertical lifts.
- GIRDER**—A supporting beam laid crosswise of the building; a long truss.
- GIRT**—A horizontal brace used on outside walls covered with vertical siding.
- GROUT**—A mixture of sand, cement, and water that can be poured.
- GUNITE**—A patent name for spray concrete.
- HONEYCOMBING**—Sections of weak, porous concrete.
- JOIST**—A member that makes up the body of the floor and ceiling frames.
- LAG SCREW**—A screw with a wrench head and wood screw threads.
- LEADS**—Points at which block and brick are laid up a few courses and used as guides.
- LINE**—Strands of natural or synthetic fiber twisted together, sometimes referred to as “rope.”
- MONOLITHIC POUR**—Concrete cast in a single pour.
- MORTAR**—Sand, water, and cementing material in proper proportions.
- MOUSING**—Turns of cordage around the opening of a block hook.
- PERLITE**—Lightweight concrete aggregate.

**PUMP CREATE**—A method of placing small aggregate concrete by means of a pump.

**PURLINS**—Horizontal members of a roof supporting the common rafters. The members span between trusses to support sheeting.

**PUTLOG**—Horizontal boards set perpendicular to scaffold lengths that directly support the platform planks.

**RAFTERS**—Main body members of roof framework.

**REEVING**—Threading or placement of a working line.

**RIDGEBOARD**—The horizontal timber at the upper end of the common rafters to which the rafters are nailed.

**SHEAVE**—A grooved wheel used to support cable or change its direction of travel (pronounced “shiv”).

**SHRINKAGE**—Concrete contraction due to curing and excess water in mix.

**SLUMP TEST**—A means of sample testing concrete for consistency; a measure of the plasticity of a concrete mix.

**SLURRY**—Thin watery mixture of water and cement.

**STRIPPING**—The removal of mold forms from hardened concrete.

**STUDS**—The vertical members of walls, wooden forms, and frames.

**TERRAZZO**—A concrete surface of Portland cement, fines, and marble chips.

**TIES**—Metal strips used to tie the outer wall of brick or masonry to the inner wall. Also used to tie concrete forms together.

**TRUSS**—A combination of members, such as beams, bars, and ties, usually arranged in triangular units to form a rigid framework for supporting loads over a span, usually a roof or bridge.

**WIRE ROPE**—A rope formed of wires wrapped around a central core; a steel cable.

## APPENDIX II

# REFERENCES USED TO DEVELOP THE TRAMAN

Although the following references were current when this TRAMAN was published, their continued currency cannot be assured. You therefore need to ensure that you are studying the latest revision.

### Chapter 1

*Naval Construction Force Manual*, NAVFAC P-315, Naval Facilities Engineering Command, Washington, D.C., 1985.

*Naval Construction Force Occupational Safety and Health Program Manual*, COMCBPAC/COMCBLANTINST 5100.1F CH-2, Commander, Naval Construction Battalions U.S. Pacific Fleet Pearl Harbor, Hawaii, and Commander, Naval Construction Battalions U.S. Atlantic Fleet, Naval Amphibious Base Little Creek, Norfolk, Va., 1991.

*Seabee Planner's and Estimators Handbook*, NAVFAC P-405, Naval Facilities Engineering Command, Alexandria, Va., 1983.

### Chapter 2

*Blueprint Reading and Sketching*, NAVEDTRA 10077-F1, Naval Education and Training Program Management Support Activity, Pensacola, Fl., 1988.

*Engineering and Design Criteria for Navy Facilities*, Military Bulletin, Naval Construction Battalion Center, Port Hueneme, Calif., 1991.

### Chapter 3

*Cabinetmaking, Patternmaking, and Millwork*, Gasper J. Lewis, Delmar Publishers Inc., Albany, N. Y., 1981.

*Carpentry I*, EN5155, U.S. Army Engineer School, Fort Belvoir, Va., 1987.

*Carpentry III*, EN0533, U.S. Army Engineer School, Fort Belvoir, Va., 1987.

### Chapter 4

*Safety and Health Requirements Manual*, EM 385-1-1, U.S. Army Corps of Engineers, Washington, D.C., 1987.

### Chapter 5

*Engineering Aid: Intermediate and Advanced*, NAVEDTRA 12540, Naval Education and Training Program Management Support Activity, Pensacola, Fla., 1994.

### Chapter 6

*Concrete and Masonry*, Headquarters, Department of the Army, Washington, D.C., 1985.

*Design and Control of Concrete Mixtures*, Portland Cement Association, 5420 Old Orchard Road, Skokie, Ill., 1988.

### Chapter 7

*Concrete Formwork*, Leonard Keel, American Technical Publishers, Inc., Home wood, Ill, 1988.

*Concrete and Masonry*, Headquarters, Department of the Army, Washington, D.C., 1985.

### Chapter 8

*Concrete and Masonry*, Headquarters, Department of the Army, Washington, D.C., 1985.

### Chapter 9

*Naval Construction Force/Seabee Petty Officer First Class*, NAVEDTRA 10601, Naval Education and Training Program Management Support Activity, Pensacola, Fla., 1989.

*Seabee Planner's and Estimator Handbook*, NAVFAC P-405, Naval Facilities Engineering Command, Alexandria, Va., 1983.





**APPENDIX III**

**HAND SIGNALS**

**GENERAL**

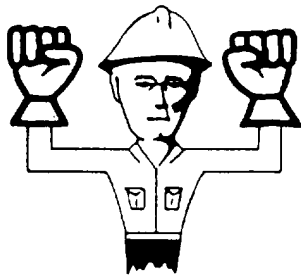

**EMERGENCY STOP**  
(STOP ALL MOTION AS QUICKLY AS POSSIBLE.)

1

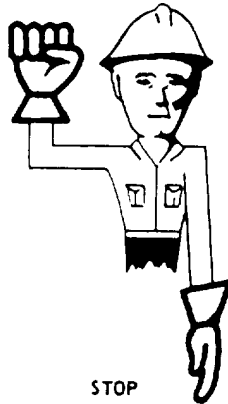

**STOP**

2

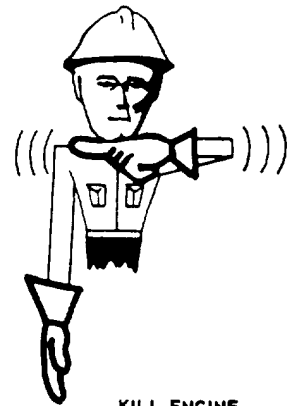

**KILL ENGINE**  
(SECURE ENGINE AS PRESCRIBED.)

3

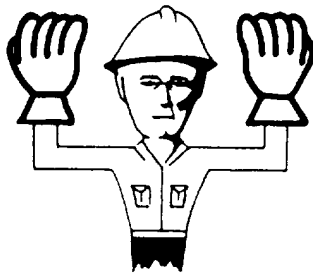

**MANEUVER FORWARD SLOW AND EASY**

(WHEN MANEUVERING IN CLOSE QUARTERS OR TO MOVE A FOOT OR TWO AT A TIME.)

4

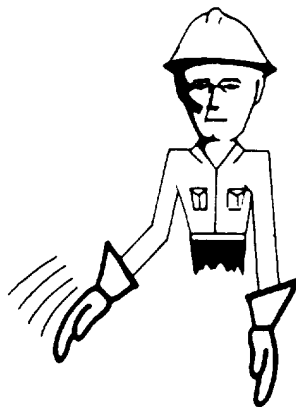

**SLOW DOWN**

5

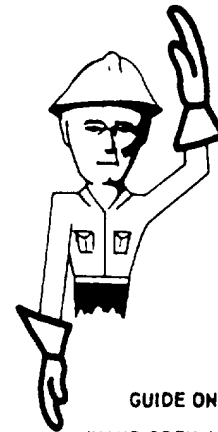

**GUIDE ON ME**  
(HAND OPEN AND PALM FACING INWARD.)

6

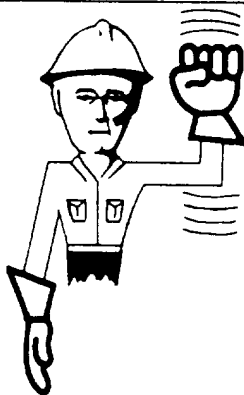

**INCREASE SPEED**

(HURRY UP AND MOVE OUT, DOUBLE TIME, ETC.)

7

**HOISTING & DERRICK SIGNALS**

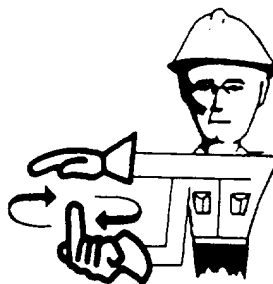

**RAISE OR HOIST SLOWLY**

8







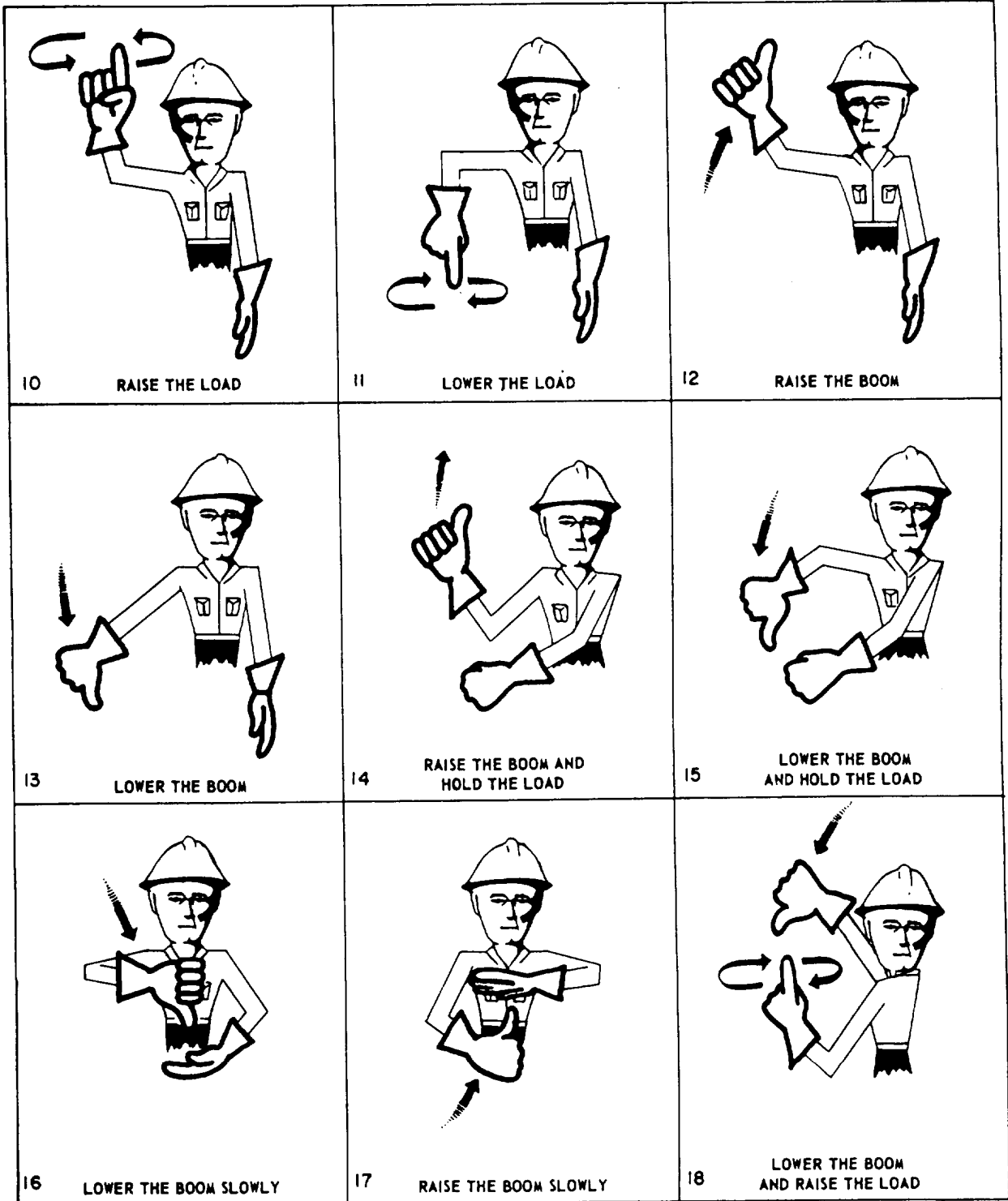

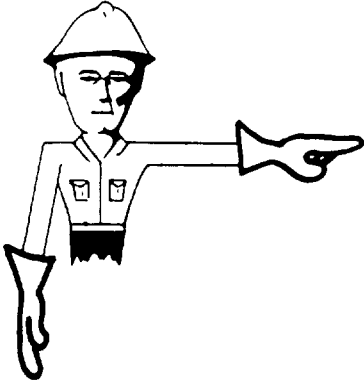
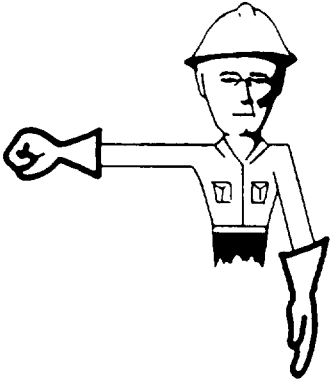
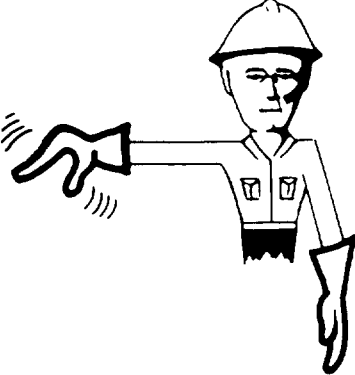
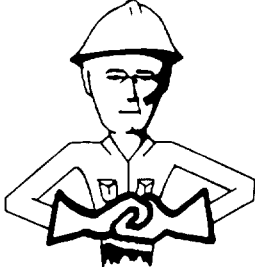
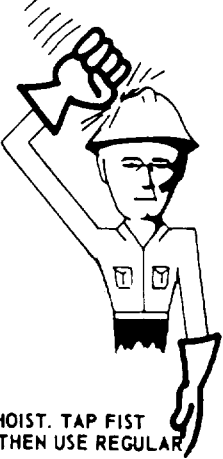
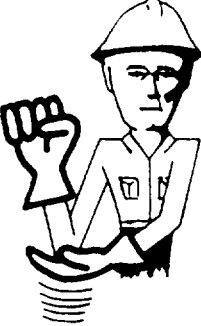
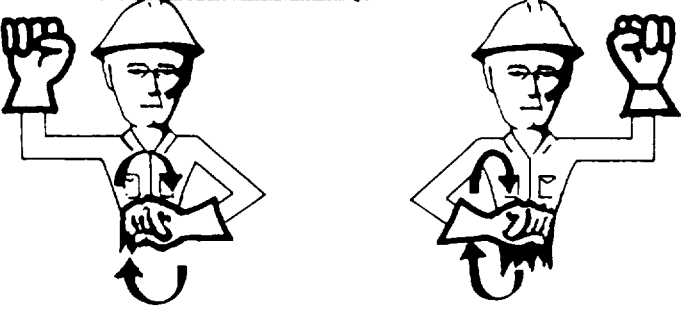
**LOWER SLOWLY**

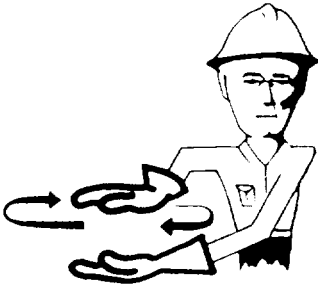
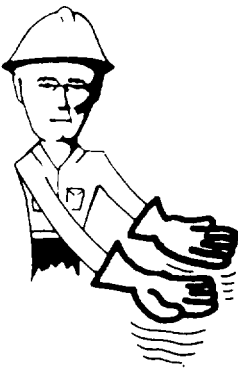
9

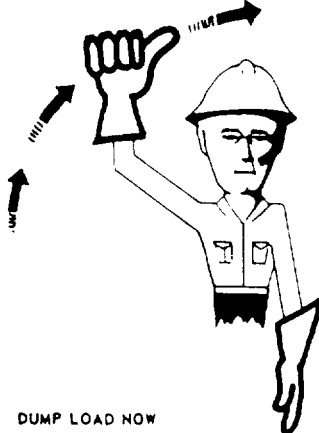

 <p>19 RAISE THE BOOM AND LOWER THE LOAD</p>	 <p>20 SWING IN DIRECTION FINGER POINTS</p>	 <p>21 CLOSE BUCKET</p>
 <p>22 OPEN BUCKET</p>	 <p>23 DOG EVERYTHING (LOCK ALL BRAKES, DO NOT MOVE UNTIL FURTHER INSTRUCTIONS ARE GIVEN.)</p>	 <p>24 USE MAIN HOIST. TAP FIST ON HEAD, THEN USE REGULAR SIGNALS.</p>
<b>CRAWLER EQUIP - INCLUDES CRANES</b>		
 <p>25 USE WHIP LINE. (AUXILIARY HOIST) TAP ELBOW WITH ONE HAND, THEN USE REGULAR SIGNALS.</p>	 <p>26 MAKE RIGHT OR LEFT TURN AS INDICATED BY CLENCHED FIST.</p> <p style="text-align: center;">LEFT <span style="margin-left: 150px;">RIGHT</span></p>	

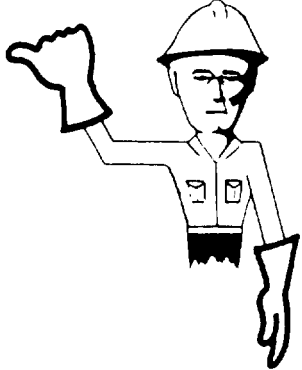
 <p>27 TRAVEL BOTH TRACKS</p>	 <p>28 WHEN CUT, FILL OR HAUL ROAD IS TO BE DRAGGED OR BLADED, POINT TO THE AREA, THEN RUB PALMS OF HANDS TOGETHER INDICATING A SMOOTHING MOTION. APPLIES TO SCRAPERS, MOTOR GRADERS AND BULLDOZERS.</p>	 <p>29 RAISE A LITTLE</p>
 <p>30 LOWER A LITTLE</p>	 <p>31 DUMP LOAD NOW (START DUMPING AND SPREADING LOAD TO PROPER DEPTH IF GIVEN.)</p>	 <p>32 REHAUL OR RETRACT</p>
 <p>33 CROWD OR EXTEND</p>	 <p>34 TURN RIGHT (TO THE OPERATOR'S RIGHT.)</p>	 <p>35 TURN LEFT (TO THE OPERATOR'S LEFT.)</p>



# INDEX

## A

Administration, 1-1

directing, 1-2

planning, 1-1

Aggregates, 6-5

handling and storage, 6-7

purpose, 6-5

quality, 6-6

types, 6-4

## B

Block and Tackle, 4-12

block construction, 4-13

block nomenclature, 4-13

hooks and shackles, 4-20

mechanical advantage, 4-15

ratio of block to line or wire, 4-13

safe working load of tackle, 4-18

snatch block and fairleads, 4-14

tackle terms, 4-12

types, 4-16

Brick masonry, 8-25

arches, 8-34

cutting, 8-34

finishing joints, 8-34

methods, 8-26

pointing, 8-29

strength, 8-26

terminology, 8-25

types, 8-25

Building layout, 5-11

3:4:5 triangle, 5-12

batter boards, 5-12

Pythagorean theorem, 5-11

## C

Cement, 6-2

air-entrained, 6-4

portland, 6-2

storage, 6-8

types, 6-2, 6-4

Concrete, 6-1

constituents of, 6-1

durability, 6-1

general requirements, 6-2

strength, 6-1

watertightness, 6-2

Concrete saw, 7-20

blades, 7-20

Consolidating concrete, 7-22

purpose, 7-22

vibration, 7-23

Construction joints, 7-17

construction, 7-19

control, 7-18

isolation, 7-17

## D

Design of structural members, 2-1

dead and live loads, 2-1

horizontal structural members, 2-4

roof trusses, 2-4

vertical structural members, 2-3

Drawings, 2-4

architectural, 2-5

assembly, 2-5

detail, 2-5, 2-16

electrical, 2-5

freehand, 2-14

mechanical, 2-5

shop, 2-13

## **E**

Elevation and reference, 5-9

grading, 5-10

principles of, 5-10

Estimating, 9-1

activity, 9-1

detailed, 9-1

equipment, 9-2

estimator, 9-2

manpower, 9-2

material, 9-2

preliminary, 9-1

## **F**

Fastening devices, 3-52

adhesives, 3-60

basic nail types, 3-52

bolts, 3-57

corrugated fasteners, 3-60

glue, 3-61

mastics, 3-61

screws, 3-54

specialty nails, 3-54

staples, 3-54

Fiber line, 4-1

fabrication, 4-1

handling and care, 4-4

natural, 4-1

size, 4-2

strength, 4-3

synthetic, 4-1

types, 4-2

Finishing concrete, 7-24

brooming, 7-28

curing, 7-29

edging, 7-27

floating, 7-26

grinding, 7-28

inspections, 7-32

screeding, 7-24

tamping, 7-26

troweling, 7-27

Formwork, 7-1

beams, 7-8

columns, 7-4

construction, 7-3

design, 7-2

failure, 7-10

foundation, 7-3

materials, 7-1

oiling, 7-10

reinforcement, 7-6

stairs, 7-8

walls, 7-5

## **H**

Hoisting, 4-21

load attaching, 4-21

safety, 4-22

shearlegs, 4-23

signalman, 4-21

tripods, 4-24

## **L**

Leveling rods, 5-5

care of, 5-9

direct readings, 5-6

Philadelphia, 5-6

rod levels, 5-8

target readings, 5-6



## Levels, 5-1

- care of, 5-5
- dumpy, 5-1, 5-2
- hand, 5-3
- leveling, 5-4
- self-leveling, 5-2
- setting up, 5-3

## M

### Masonry, 8-1

- block sizes, 8-4, 8-16
- estimating, 8-9
- handling, 8-12
- joints, 8-6
- modular planning, 8-8
- mortar, 8-6
- tools and equipment, 8-1

### Masonry construction, 8-13

- bond beams, 8-21
- control joints, 8-18
- lintels, 8-21
- painting, 8-24
- patching and cleaning, 8-23
- piers and pilasters, 8-21
- reinforced block walls, 8-23
- steps, 8-13
- walk, 8-19

### Materials, 3-21

- classification, 3-26
- common woods, 3-21
- defects and blemishes, 3-25
- hardwood grade, 3-28
- laminated, 3-29
- seasoning of, 3-25
- sizes, 3-28
- softwood grades, 3-26

## Millwork, 3-47

- cabinet facing, 3-49
- cabinets built in-place, 3-47
- counters and tops, 3-52
- doors, 3-50
- drawers, 3-50
- installing premade cabinets, 3-50
- laminates, 3-52
- shelving cabinet, 3-48

## Mix design, 6-8

- batching, 6-13
- grout, 6-12
- ingredient proportions, 6-8
- material estimates, 6-10
- slump test, 6-11
- workability, 6-12

## Mixing concrete, 6-14

- hand mixing, 6-14
- machine mixing, 6-14
- transporting, 6-16

## P

### Placing concrete, 7-21

### Planning, 9-1

- documentation, 9-3
- project folders, 9-4

### Plans, 2-9

- elevations, 2-12
- floor, 2-10, 2-12
- foundation, 2-10
- framing, 2-12
- plot, 2-9
- roof, 2-13
- site, 2-9

- Plywood, 3-30
  - exposure rating, 3-36
  - exterior, 3-31
  - grade/trademark stamp, 3-33
  - hardwood grades plywood, 3-36
  - interior, 3-31
  - softwood grades plywood, 3-33
- Portable hand power tools, 3-12
  - circular saw, 3- I 3
  - power drills, 3-19
  - power plane, 3-18
  - reciprocating saw, 3-16
  - router, 3-17
  - saber saw, 3-15
  - sanders, 3-19
  - staplers and nailers, 3-20
- Precast and tilt-up Concrete, 6-17
  - attachments, 6-20
  - bond breaking agents, 6-19
  - bracing, 6-21
  - casting, 6-18
  - forms, 6-19
  - lifting equipment, 6-20
  - pouring, 6-20
  - reinforcement and inserts, 6-20
- R**
- Reinforced concrete, 7-12
  - location of, 7-14
  - reinforcing steel, 7-12
  - splicing, 7-17
  - welded wire, 7-12
- S**
- Safety, 1-6
  - duties, 1-7
  - organization, 1-6
  - stand up safety meetings, 1-7
  - training, 1-7
- Scaffolding, 4-26
  - bracket, 4-28
  - pole, 4-27
  - prefabricated, 4-27
  - swinging, 4-26
- Schedules, 2-16
  - door, 2-16
  - finish, 2-16
  - notes, 2-18
  - window, 2-16
- Scheduling, 9-2
  - network analysis, 9-3
  - progress control, 9-3
- Sectional views, 2-14
  - specific, 2-15
  - typical, 2-15
- Shop tools, 3-1
  - band saw, 3-3
  - drill press, 3-4
  - jointer, 3-8
  - radial arm saw, 3-1
  - shaper, 3-11
  - surfacers, 3-10
  - tilt-arbor table bench saw, 3-1
  - woodworking lathe, 3-6
- Specifications, 2-18
  - EFD regional guide, 2-18
  - federal and military, 2-20
  - manufacturer's, 2-20
  - NAVFAC, 2-18
  - NAVFACENGCOM guide, 2-18
  - organization, 2-20
  - project, 2-20
  - standard, 2-19
  - technical society and trade association, 2-20

## T

### Timekeeping, 1-3

direct labor, 1-4

military operations and readiness, 1-4

overhead labor, 1-4

productive labor, 1-4

timekeeping card, 1-5

training, 1-4

### Tool kit inventory, 1-2

NAVSUP 1250, 1-3

preparing requisitions, 1-3

## W

### Wire rope, 4-4

attachments, 4-10

coiling and uncoiling, 4-7

construction, 4-4

failure of, 4-6

### Wire rope-Continued

grades, 4-5

handling and care, 4-7

inspection, 4-10

kinks, 4-8

lubrication, 4-9

measurement of, 4-6

safe working loads, 4-6

storage, 4-10

### Woodworking joints, 3-37

box corner, 3-45

coping, 3-45

dovetail, 3-44

grooved, 3-41

half-lap, 3-40

miter, 3-37, 3-41

mortise-and-tenon, 3-39, 3-42

rabbet, 3-39



---

---

# *Assignment Questions*

---

---

**Information:** The text pages that you are to study are provided at the beginning of the assignment questions.



# ASSIGNMENT 1

Textbook Assignment: Chapter 1 - Construction Administration and Safety  
Chapter 2 - Drawings and Specifications

---

- 1-1. When you become a Builder petty officer, you automatically assume which of the following additional responsibilities?
1. Company clerk
  2. Project manager
  3. Project estimator
  4. Crew leader
- 1-2. When planning a project, you must consider both the tools and equipment you will need and the capability of the crew?
1. True
  2. False
- 1-3. To ensure a job is completed on schedule, you should take which of the following actions?
1. Order extra equipment
  2. Conduct disaster control training
  3. Demand quantity work
  4. Encourage teamwork and establish goals
- 1-4. A crewmember is incorrectly doing a job. As crewleader, what action should you take?
1. Place the crewmember on report
  2. Assign extra work to the crewmember
  3. Stop the crewmember and give correct job procedures
  4. Transfer the crewmember to another crew
- 1-5. Which of the following actions will aid you, as a crew leader, in developing teamwork?
1. Rotating crewmembers on various phases of the job
  2. Developing an environment where the crewmembers feel free to seek you out for advice
  3. Maintaining a high level of morale
  4. All of the above
- 1-6. A standard Builder tool kit contains the hand tools required for what maximum size crew?
1. Five persons
  2. Two persons
  3. Six persons
  4. Four persons
- 1-7. As a crew leader, you are NOT authorized to draw the tools required by the individual crewmembers.
1. True
  2. False
- 1-8. What form should a crew leader use to order materials?
1. DD 1148
  2. DD 1250
  3. NAVSUP 1149
  4. NAVSUP 1250
- 1-9. Information on the National Stock Number system is found in which of the following RTMs?
1. *Tools and Their Uses*
  2. *Military Requirements for Petty Officer 3 & 2*
  3. *Blueprint Reading and Sketching*
  4. *Constructionman TRAMAN*

- 1-10. When filling out a time card, what code should you give labor required to support construction operations but that does not itself produce an end product?
1. Direct
  2. Indirect
  3. Overhead
  4. Military
- 1-11. Labor that contributes directly to the completion of the end product is considered what type?
1. Direct
  2. Indirect
  3. Overhead
  4. Military
- 1-12. Compared to productive labor, overhead labor does not contribute directly or indirectly to the completion of an end product.
1. True
  2. False
- 1-13. After being filled in, a daily labor distribution report should be initialed by whom?
1. The assistant company commander
  2. The platoon commander
  3. The company chief
  4. The company commander
- 1-14. The daily labor distribution reports from all companies are compiled and tabulated by the
1. company clerk
  2. operations chief
  3. management division of the operations department
  4. operations officer
- 1-15. As a petty officer, you must be familiar with the safety program at your activity.
1. True
  2. False
- 1-16. The safety policy committee is presided over by what person?
1. The safety officer
  2. The company chief
  3. The administrative officer
  4. The executive officer
- 1-17. What is the primary purpose of the safety policy committee?
1. Develop safety rules and policy for the battalion
  2. Discipline personnel who are involved in accidents
  3. Elect a battalion safety chief and committee
  4. Review all vehicle accident reports and determine the causes of accidents
- 1-18. What is the primary purpose of the safety supervisors' committee?
1. Establish work procedures
  2. Encourage safe practices
  3. Review safety suggestions
  4. All of the above
- 1-19. Which of the following committees reviews vehicle mishaps?
1. The safety supervisors' committee
  2. The safety policy committee
  3. The responsible crew
  4. The equipment committee
- 1-20. As a crew leader, you are NOT responsible for the safe working practices of individual crewmembers?
1. True
  2. False
- 1-21. When an unsafe working condition exists, which of the following Individuals can stop the work until the unsafe condition is corrected?
1. The crewmember
  2. The crew leader
  3. The project safety supervisor
  4. Any of the above



- 1-22. Who among the following individuals is responsible for conducting stand-up safety lectures?
1. The safety chief
  2. The safety officer
  3. The crew leader
  4. The company commander
- 1-23. Of the following, which is the best safety technique a crew leader can apply?
1. Stand-up meetings
  2. Reprimanding violators in view of their peers
  3. Designating a crewmember as the safety representative
  4. Leadership by example
- 1-24. At any given time, building structural members must be able to support which of the following loads?
1. Dead loads only
  2. Live loads only
  3. Total dead plus total live loads
  4. Dead load minus live load
- 1-25. Which of the following building structural members provide immediate support for live loads?
1. Footings
  2. Horizontal members
  3. Vertical members
  4. Diagonal members
- 1-26. Which of the following statements best applies to an outside wall column?
1. It is usually located directly over the inside lower floor columns
  2. It rests on the ground and extends to the roof line
  3. It is a high-strength horizontal structural member
  4. It is a high-strength vertical structural member usually extending from the footing to the roof line
- 1-27. What type of column is used to support the lowest horizontal building member?
1. Bottom floor inside
  2. Outside-wall
  3. Upper floor
  4. Short
- 1-28. The building components supporting the chief vertical structural members (studs) are known as
1. piers
  2. sills
  3. beams
  4. bar joists
- 1-29. The building component above the wall studs and supporting roof framing members is called a
1. header
  2. rafter plate
  3. stud
  4. sill
- 1-30. Rafters are horizontal or inclined members providing roof support.
1. True
  2. False
- 1-31. The peak ends of rafters are supported by
1. purlins
  2. rafter plates
  3. a ridgeboard
  4. studs
- 1-32. A load on a beam is too great for structural integrity and supports cannot be used under the beam. What other structural member can be used to adequately support the load?
1. Pier
  2. Truss
  3. Suspension cable
  4. Rafter

- 1-33. In light frame construction, which of the following trusses is the simplest type used?
1. W-type
  2. Scissors
  3. Hip
  4. King-post
- 1-34. Engineering and architectural design sketches are combined to form what type of drawings?
1. Construction
  2. Perspective
  3. Combination
  4. Symbol
- 1-35. Of the following types of drawings, which is NOT one of the three main drawing groups?
1. Architectural
  2. Mechanical
  3. Detail
  4. Electrical
- 1-36. Drawings that are adequate for a Builder to complete a project are known as
1. assembly drawings
  2. working drawings
  3. detail drawings
  4. a Bill of Materials
- 1-37. Where are you most likely to find information on items too small to appear on general drawings?
1. Detail drawings
  2. Assembly drawings
  3. Bill of Materials
  4. Specifications
- 1-38. What type of drawing is either an exterior or sectional view of an object showing details in proper relationship to one another?
1. Design
  2. Construction
  3. Assembly
  4. General
- 1-39. General drawings are plans (views from above) and elevations (side or front views) drawn on a small scale.
1. True
  2. False
- 1-40. The contours, boundaries, utilities, structures, and other significant physical features of a piece of property are shown on what type of plan?
1. Plot
  2. Site
  3. General
  4. Elevation
- 1-41. What plan should be used to set batter boards and line stakes?
1. Plot
  2. Site
  3. Detail
  4. General
- 1-42. For a footing, the material used and the depth are shown on what type of plan?
1. Floor
  2. Site
  3. Foundation
  4. Elevation
- 1-43. The dimensions, number, and arrangement of structural members in wood-frame construction are shown in what type of plan?
1. Foundation
  2. Floor
  3. Wall framing
  4. Detail
- 1-44. To check the overall height of finished floors, doors, and windows, you should consult what plan?
1. Plot
  2. Elevations
  3. Section
  4. Floor

- 1-45. What plan shows the type of wall and roof covering required?
1. Elevation
  2. Floor
  3. Plot
  4. Foundation
- 1-46. What plan specifies the sizes and spacing of joists, girders, and columns used to support the floor?
1. Plot
  2. Floor framing
  3. Section
  4. Elevations
- 1-47. Sectional views, or sections, provide important information about the height, materials, fastening and support systems, and concealed features of a structure.
1. True
  2. False
- 1-48. Detail drawings give construction information about which of the following items?
1. Doors
  2. Windows
  3. Eaves
  4. All of the above
- 1-49. A schedule is a table or list of working drawings giving number, sizes, and placement of similar items.
1. True
  2. False
- 1-50. Which of the following schedules specifies the interior finish material for each room and floor?
1. Door
  2. Floor
  3. Window
  4. Interior
- 1-51. Which of the following items supplement construction drawings with detailed written instructions?
1. Specifications
  2. Notes
  3. Revisions
  4. Details
- 1-52. How many types of NAVFAC specifications govern work performed by Seabees?
1. One
  2. Two
  3. Three
  4. Four
- 1-53. Which of the following NAVFAC specifications are written for a small group of specialized structures that must have uniform construction to meet rigid operational requirements?
1. NAVFACENGCOCOM guide specifications
  2. EFD regional guide specifications
  3. Standard specifications
  4. Other specifications
- 1-54. Which of the following specifications do NOT cover installation or workmanship for a particular project?
1. Technical society and trade association specifications
  2. Federal and military specifications
  3. Manufacturer's specifications
  4. Project specifications
- 1-55. Specifications from which of the following sources, combined with drawings, define the project in detail and show exactly how it is to be constructed?
1. The American Society for Testing and Materials
  2. The American National Standards Institute
  3. Manufacturers specifications
  4. Project specifications

- 1-56. Whenever there is conflicting information between the drawings and project specs, the specifications take precedence over the drawings.
1. True
  2. False
- 1-57. A specifications format contains what total number of divisions?
1. 10
  2. 12
  3. 14
  4. 16
- 1-58. Which of the following specifications divisions provides information on concrete masonry units. brick, stone, and mortar?
1. Concrete
  2. Masonry
  3. Site work
  4. General requirements
- 1-59. The specifications division that includes items such as medical equipment, laboratory equipment, and food service equipment is called the specialties division.
1. True
  2. False
- 1-60. How many parts do the technical sections of specifications break down to?
1. One
  2. Two
  3. Three
  4. Four

## ASSIGNMENT 2

Textbook Assignment: Chapter 3 - Woodworking Tools, Materials, and Methods

---

- 2-1. Which of the following shop tools is similar to a trailer-mounted field saw?
1. Shop radial-arm saw
  2. Table saw
  3. Band saw
  4. Circular saw.
- 2-2. When using the tilt-arbor bench saw, which of the following parts moves?
1. The table
  2. The throat plate
  3. The arbor
  4. The cutoff gauge
- 2-3. On a tilt-arbor bench saw, the saw blade for ordinary ripping and cutting should extend how far above the table top?
1. 1/32 to 1/16 inch plus thickness of material
  2. 1/16 to 1/8 inch plus thickness of material
  3. 1/8 to 1/4 inch plus thickness of material
  4. 1/4 to 3/8 inch plus thickness of material
- 2-4. Which combination of grooving saws and chisel-type cutters makes up a dado head?
1. One saw and one cutter
  2. One saw and two cutters
  3. Two saws and one or more cutters
  4. Three saws and two cutters
- 2-5. When cutting a piece of material on a table saw, where should you stand?
1. In front of the saw
  2. To the side of the saw
  3. In line with the material
  4. Behind the saw
- 2-6. To remove material from the other side of a table saw when it is in operation, you should reach over the table.
1. True
  2. False
- 2-7. Material should be fed to a table saw blade at what speed?
1. As fast as possible
  2. No faster than you can pull
  3. As slow as you can
  4. As fast as it can cut freely and cleanly
- 2-8. The band saw is primarily designed for which of the following cuts?
1. Freehand
  2. Curved
  3. Straight
  4. Miter
- 2-9. How is the size of a band saw designated?
1. Tooth points per inch
  2. Width and gauge of the blade
  3. Diameter of the wheels
  4. Cutoff gauges and gears
- 2-10. Which of the following terms is NOT used in designating a band saw blade?
1. Circumference
  2. Points
  3. Gauge
  4. Width
- 2-11. A clicking sound develops while you are cutting material with a band saw. The sound is an indication of what blade problem?
1. Binding
  2. Crack
  3. Pinch
  4. Too small

- 2-12. A hand or foot break should be installed on all band saws of what size(s)?
1. 18 inches or smaller
  2. 24 inches
  3. 30 inches
  4. 36 inches or larger
- 2-13. Which of the following accessories allow(s) a drill press to become a more versatile woodworking tool?
1. Shaper heads
  2. Router bit
  3. Jig
  4. All of the above
- 2-14. How is drill press speed changed?
1. By a two-speed control switch
  2. By the location of the V-belt the spindle
  3. By a variable speed control knob
  4. By changing the drive pulley
- 2-15. On a drill press, the spindle and quill assembly is controlled by what component?
1. Head lock handle
  2. Head collar support lock handle
  3. Quill lock handle
  4. Spindle/quill feed handle
- 2-16. When operating a drill press. you should ensure the head lock handle is tight at all times.
1. True
  2. False
- 2-17. At what maximum angle from horizontal can you tilt a drill press table?
1. 10°
  2. 25°
  3. 30°
  4. 45°
- 2-18. On a drill press, which of the following features allows you to regulate drilling depth?
1. Table lock handle
  2. Head lock handle
  3. Adjustable locknut
  4. Head support collar handle
- 2-19. The size of a wood lathe is determined by what factor?
1. The diameter of the stock that the lathe will accommodate
  2. The circumference of the stock that the lathe will accommodate
  3. The length of stock that can be mounted on the lathe
  4. The horsepower of the lathe motor
- 2-20. How many major parts does a wood lathe have?
1. One
  2. Two
  3. Three
  4. Four
- 2-21. Of the major wood lathe parts, which one supports all other major parts?
1. The bed
  2. The headstock
  3. The tailstock
  4. The tool rest
- 2-22. What wood lathe part can be moved along the length of the lathe's bed?
1. The headstock
  2. The tailstock
  3. The motor spindle
  4. The faceplate
- 2-23. Which of the following special tools are chiefly used to rough out nearly all shapes formed by spindle turning?
1. Turning gouges
  2. Skew chisels
  3. Parting tools
  4. Scraping tools

- 2-24. Scraping tools of various shapes are used for most accurate turning work, especially for most faceplate turning.
1. True
  2. False
- 2-25. Which of the following special tools allows you to cut recess or grooves with straight sides and a flat bottom?
1. Skew chisels
  2. Scraping tools
  3. Parting tools
  4. Turning gouges
- 2-26. When operating a woodworking lathe, which of the following practices is safe?
1. Standing to one side when starting the motor
  2. Making adjustments with the motor running
  3. Using calipers on irregular surfaces while the lathe is in motion
  4. Milling stock freehand
- 2-27. When using a jointer, loosening the set screws forces the throat piece against the knife for holding the knife in position.
1. True
  2. False
- 2-28. When a jointer makes a cut deeper at the beginning of the cut than at the end, you should adjust the jointer by
1. raising the infeed table
  2. lowering the infeed table
  3. raising the outfeed table
  4. lowering the outfeed table
- 2-29. The fence on a jointer can be set to produce beveled edges at which of the following angles?
1. 45° only
  2. 60° only
  3. 75° only
  4. Any desired angle
- 2-30. Setting jointer knives at too heavy a cut can cause which of the following problems?
1. The jointer to stop
  2. Gaps in the spindle
  3. Kickback
  4. A sharp edge to form on the outfeed table
- 2-31. When operating a jointer, you should always plane with the grain.
1. True
  2. False
- 2-32. Which of the following statements regarding surfacers is NOT true?
1. A surfacer can only surface
  2. A surfacer can remove warps from lumber
  3. A surfacer can surface only one side
  4. A surfacer cuts with a butterhead located below the drive rollers
- 2-33. How should you true a warped board and plane its top surface if the available tools include a jointer and a single surfacer?
1. Simply feed the board once through the surfacer
  2. Feed the board through the surfacer, then turn over the board and feed it through again
  3. True one face of the board on the jointer, then feed the board through the surfacer with the true face down
  4. True one face of the board on the jointer, then feed the board through the surfacer with the trued face up
- 2-34. When operating a surfacer, what component should you have in place over the cutting head?
1. Plastic guard
  2. The infeed table
  3. The vacuum hood
  4. A metal guard

- 2-35. A piece of material becomes stuck during surfacing. Which of the following procedures should you follow to remove it?
1. Stop the surfacer and lower the feed bed
  2. Stop the surfacer and push out the material
  3. Keep the surfacer running and pull out the material
  4. Keep the surfacer running and use another piece of stock to push out the material
- 2-36. A shaper is primarily designed for which of the following operations?
1. Rabbeting and grooving
  2. Edging curved stock and cutting ornamental edges
  3. Surfacing the face of large pieces of stock
  4. Edging flat, smooth surfaces
- 2-37. When shaping an edge on a shaper, how should you feed the stock to the cutter head?
1. Feed stock in the same direction as the spindle is rotating only
  2. Feed stock against the rotation of the spindle only
  3. Feed stock in the same direction as the spindle is rotating, then reverse and feed against the rotation of the spindle
  4. Feed the stock through in either direction
- 2-38. If tuned or irregular edges are to be shaped, you should remove the straight fence and replace with what component?
1. A starting pin placed in the table top
  2. A C-clamp with a hand screw
  3. A three-wing cutter
  4. A straightedge board
- 2-39. The size of a circular saw is determined by what factor?
1. The size of the motor
  2. The size of the smallest blade
  3. The size of the largest blade
  4. The size of the guard
- 2-40. On a circular saw, which of the following types of blades is considered an all purpose blade used for cutting all thickness of wood with or across the grain?
1. Abrasive
  2. Crosscut
  3. Rip
  4. Combination
- 2-41. Hollow-ground blades have no set and make the smoothest cuts on thick or thin stock.
1. True
  2. False
- 2-42. When cutting materials with a portable electric circular saw, you should use which of the following procedures?
1. Hold the saw with the right hand and guide the work with the left hand
  2. Hold the saw with both hands firmly against the work
  3. Hold the saw with both hands after removing the blade guard
  4. Hold the saw with both hands lightly against the work
- 2-43. If you do not maintain a firm grip on a saber saw during cutting, the saw will tend to
1. burn the wood
  2. overheat
  3. excessively vibrate
  4. stop cutting



- 2-44. To start a cut with a saber saw, what technique should you use?
1. Press the blade into the material and start the motor
  2. Pull back on the blade and start the motor
  3. Start the motor and push the material into the blade
  4. Start the motor and push the blade into the material
- 2-45. When using a reciprocating saw to start a cut, you should place the blade near the material, start the motor, and then move the blade into the material.
1. True
  2. False
- 2-46. The cutting depth of a router is maintained by adjusting what component?
1. The depth setscrew
  2. The depth ring
  3. The chuck nut
  4. The edge guide
- 2-47. Which of the following router features allows you to guide the router in a straight line and is particularly useful for cutting grooves on long pieces of lumber?
1. The depth setscrew
  2. The depth ring
  3. The chuck nut
  4. The edge guide
- 2-48. When operating a router, you should use one hand to steady the router and one hand to secure the material.
1. True
  2. False
- 2-49. Safe operation of any portable power plane requires a single pass cut be less than what maximum depth?
1. 1/8 in
  2. 1/16 in
  3. 3/32 in
  4. 1/4 in
- 2-50. To get a bevel cut using a portable power plane, what action should you take?
1. Loosen the base, set base at desired level, then retighten
  2. Tilt the planer to the desired angle
  3. Tilt the material to the desired angle
  4. Adjust the blade to the desired angle
- 2-51. Which of the following characteristics distinguishes a standard drill from a specialty drill?
1. Spade design
  2. Pistol-grip design
  3. Right-angle
  4. Variable speed
- 2-52. Which of the following sander types is ideal for the removing old finishes from wood flooring, siding, and concrete?
1. Belt
  2. Disk
  3. Orbital
  4. Oscillating
- 2-53. The size designation of a belt sander is determined by the size of the wheels.
1. True
  2. False
- 2-54. When using a disk sander to remove old paint, what method should you use?
1. Lay the disk flat on the surface and apply light pressure
  2. Lay the disk flat on the surface and apply heavy pressure
  3. Lay the disk on its edge and apply enough to bend it at a 45° angle
  4. Tip the machine slightly and apply just enough pressure to bend the disk slightly

- 2-55. All air-powered nailers use the same air pressure
1. True
  2. False
- 2-56. When using power nailers or staplers, which of the following operations is NOT safe?
1. Using standard air pressure
  2. Keeping the nose of the nailer or stapler pointed away from your body or other people
  3. Leaving the tool connected to the air when loading or not in use
  4. Using standard nails or staples
- 2-57. Timber is wood cut to which of the following dimensions?
1. 1-by-12 inches by 8 ft
  2. 2-by-12 inches by 8 ft
  3. 3-by-5 inches by 12 ft
  4. 5-by-7 inches by 16 ft
- 2-58. Which of the following factors is NOT an advantage of seasoned lumber?
1. Decreased shrinkage
  2. Increased strength
  3. Reduced weight
  4. Increased warpage
- 2-59. Lumber is considered dry enough for most uses when its moisture content is in what range?
1. 12% to 15%
  2. 17% to 19%
  3. 20% to 23%
  4. 25% to 28%
- 2-60. As a Builder, you should be able to judge the moisture content of lumber by which of the following characteristics?
1. Taste, color, and weight
  2. Color, weight, smell, and feel
  3. Color, grain, and smell only
  4. Taste, grain, color, and smell

## ASSIGNMENT 3

Textbook Assignment: Chapter 3 - Woodworking Tools, Materials, and Methods  
(continued)

---

- 3-1. A blemish in a piece of lumber is classified as a defect when it affects what quality?
1. Utility value
  2. Strength
  3. Durability
  4. Size
- 3-2. A root section of a branch appearing on the surface of a board is what kind of defect?
1. Pitch pocket
  2. Knot
  3. Check
  4. Shake
- 3-3. A twist or curve that develops in a flat board is what kind of defect?
1. Shake
  2. Wane
  3. Check
  4. warp
- 3-4. Which of the following types of wood should be used where strength is the primary requirement?
1. Yard lumber
  2. Shop lumber
  3. Structural lumber
  4. Factory lumber
- 3-5. Using manufacturing classifications, wood that has not been dressed but has been sawed, edged, and trimmed is considered what type?
1. Worked lumber
  2. Rough lumber
  3. Dressed lumber
  4. Matched lumber
- 3-6. Which of the following qualities is NOT considered when grading lumber?
1. Uniformity
  2. Strength
  3. Stiffness
  4. Appearance
- 3-7. Where will you find the grade of lumber to be used on a construction project?
1. Blueprints
  2. File folder 1
  3. Specifications
  4. DD 1250
- 3-8. From the following grade listings, which is nearly free of defects and blemishes?
1. Grade A select
  2. Grade B
  3. No. 1 common
  4. No. 5 common
- 3-9. FAS grade of hardwood lumber should have what portion of clear cutting?
1. 48 1/3%
  2. 65 2/3%
  3. 66 2/3%
  4. 83 1/3%
- 3-10. The nominal size of lumber is larger than actual dressed dimensions.
1. True
  2. False
- 3-11. What is the primary advantage of laminated lumber?
1. Light weight
  2. Low cost
  3. Increased load-carrying capacity
  4. Increased resistance to decay

- 3-12. The greatest use of lamination is in the fabrication of large beams and arches.
1. True
  2. False
- 3-13. Most lamination splices are made with what type of joint?
1. Tongue-and-groove
  2. Scarf
  3. Shiplap
  4. Half-lap
- 3-14. By weight, plywood is one of the strongest building materials available. Which of the following factors is primarily responsible for this strength?
1. Cross lamination
  2. High-strength glue
  3. Number of plies
  4. Grade of wood
- 3-15. In a sheet of plywood, the outer plies are called
1. crossbands only
  2. cores only
  3. crossbands and cores
  4. faces or face and back
- 3-16. What is the essential difference between exterior and interior plywood?
1. The grain
  2. The thickness
  3. The plies
  4. The glues
- 3-17. Plywood is manufactured only in various thicknesses in a range from 1/4 to 3/4 inch.
1. True
  2. False
- 3-18. Using stiffness and strength as criteria, plywood can be classified into what maximum number of groups?
1. Five
  2. Two
  3. Three
  4. Four
- 3-19. What veneer grade of plywood permits knots and knotholes to 2 1/2 inch in width (1/2 inch larger under specified conditions)?
1. A
  2. B
  3. D
  4. N
- 3-20. Plywood with a solid surface veneer and circular repair plugs is what grade?
1. A
  2. B
  3. C
  4. N
- 3-21. On plywood, which of the following trademark stamps gives you the span rating?
1. Industrial
  2. Construction
  3. Interior
  4. Exterior
- 3-22. What class of plywood is best suited for exposure to extended periods of moisture?
1. Exterior
  2. Exposure 1
  3. Exposure 2
  4. Interior
- 3-23. To ensure a tight joint on cut lumber, which of the following procedures should you follow?
1. Cut on the waste side of the line
  2. Cut directly in the middle of the line
  3. Cut out the entire line
  4. Cut out the line plus a little extra

- 3-24. In laying off a piece of lumber for an end-butt half-lap joint, the shoulder line should be drawn around the board at what distance from the end of the board?
1. One-half board width
  2. One board width
  3. One board thickness
  4. Any desired amount
- 3-25. When laying off a piece of lumber for a half-lap joint, you gauge the cheek line from what point?
1. The edge only
  2. The face only
  3. The edge or end
  4. The face or end
- 3-26. In cutting an end-butt half-lap joint on a piece of lumber, what cut should you make first?
1. Face
  2. Shoulder
  3. Back
  4. Cheek
- 3-27. When mitering a board for a hexagonal (six-sided) frame, what miter angle should you use?
1. 22.5°
  2. 30.0°
  3. 60.0°
  4. 67.5°
- 3-28. When reinforcing miter joints, slip feathers are often preferred over corrugated fasteners because slip feathers
1. are stronger
  2. are easier to apply
  3. are easier to remove
  4. look better
- 3-29. A three-sided recess-running across the grain from one side of a board to the other is known by what term?
1. Grooved joint
  2. Stopped dado
  3. Dado
  4. Stopped groove
- 3-30. A two-sided recess running along an edge of a board is known by what term?
1. Groove
  2. Dado
  3. Stopped dado
  4. Rabbet
- 3-31. A circular saw can be used to cut a stopped groove if you use which of the following attachments?
1. A stopped block
  2. A rabbet ledge
  3. A haunch board
  4. A carriage block
- 3-32. To adjust the fence to the depth of the cheek when cutting a rabbet joint with a circular saw, you should measure from what point?
1. The left side of the raker tooth
  2. The center line of the saw blade
  3. The sawtooth set to the left
  4. The sawtooth set to the right
- 3-33. With proper attachments, jointers can be used for rabbeting.
1. True
  2. False
- 3-34. Which of the following mortise-and-tenon joints penetrates through the mortised member?
1. Stub
  2. Blind
  3. Through
  4. Haunched
- 3-35. Table haunching a mortise-and-tenon joint has what effect on the joint?
1. Makes it weaker
  2. Makes it tighter
  3. Makes it easier to construct
  4. Makes it stronger

- 3-36. When a tenon member is too thin to permit shoulder cuts on both faces, what kind of mortise-and-tenon joint should you use?
1. Barfaced
  2. Stub
  3. Haunched
  4. Table haunched
- 3-37. What type of woodworking joint is considered the strongest?
1. Mortise-and-tenon
  2. Rabbet
  3. Tongue-and-groove
  4. Dovetail
- 3-38. When cutting inside corner molding, you should normally use which of the following handsaws?
1. Backsaw
  2. Hacksaw
  3. Coping saw
  4. Jigsaw
- 3-39. When you build cabinets in place, what step follows installation of the base?
1. Cut the bottom panels and nail them in place
  2. Cut end panels and install
  3. Cut front edge and install
  4. Cut counter top to length
- 3-40. You can increase the strength of a set of cabinets by using what type of joint for the shelves?
1. Blind mortise-and-tenon
  2. Tongue and groove
  3. Dado
  4. Rabbet
- 3-41. When you use 3/4-inch material for shelves, what should be the maximum distance between shelf supports?
1. 16 in
  2. 24 in
  3. 36 in
  4. 42 in
- 3-42. Which of the following drawer fronts, if any, is the easiest to construct?
1. Flush
  2. LIP
  3. Sliding
  4. None of the above
- 3-43. Which of the following cabinet door types is designed to cover the edge of the face frame?
1. Overlay
  2. Flush
  3. Lipped
  4. Sliding
- 3-44. What is the first thing you should do when installing premade cabinets base-first?
1. Locate wall studs and find the highest point on the floor
  2. Install cabinet base and locate the wall studs
  3. Locate the highest point on the floor and install the cabinet base
  4. Locate the highest point on the floor, then level the leading edge of the cabinets
- 3-45. Which of the following fasteners should you use to hang cabinets on a wall?
1. Spiral nails
  2. Annular nails
  3. Screws
  4. Stove bolts
- 3-46. When installing laminated counter tops, you should use base material that has which of the following characteristics?
1. 1/2 inch thick only
  2. 3/4 inch thick only
  3. Smooth, 1/2 inch thick
  4. Smooth, 3/4 inch thick
- 3-47. When cutting a piece of laminate, you should cut it at least 1/4 inch larger than the desired size,
1. True
  2. False

- 3-48. What type of nail should you use for wood trim?
1. Common
  2. Casing
  3. Brad
  4. Box
- 3-49. You are nailing a 1-inch thick board. The nail used should be what length?
1. 1 1/2 in
  2. 2 in
  3. 3 in
  4. 4 in
- 3-50. Which of the following nailing techniques gives maximum holding power?
1. Drive the nails with the grain
  2. Drive the nails at an angle toward each other
  3. Drive the nails vertically
  4. Drive the nails through an edge
- 3-51. Of the following nail types, which has the greatest holding power?
1. Box
  2. Common
  3. Spiral
  4. Finish
- 3-52. Of the following nail types, which is most suitable for temporary work such as forms and scaffolding?
1. Duplex head
  2. Common
  3. Box
  4. Annular
- 3-53. Compared to nails, screws have which of the following advantages?
1. Cheaper
  2. Neater appearance
  3. Can be withdrawn with less damage
  4. Safer
- 3-54. To what depth should you drill a wood screw starter hole?
1. 1/4 to 1/2 the length of the threads
  2. 1/2 to 5/8 the length of the threads
  3. 1/2 to 2/3 the length of the threads
  4. 2/3 to 3/4 the length of the threads
- 3-55. When spikes are not sufficiently strong and ordinary wood screws are too light, what type of screw should you use?
1. Flathead
  2. Sheet metal
  3. Round head
  4. Lag
- 3-56. What type of fastener should you use when great strength or frequent disassembly is required?
1. Carriage bolt
  2. Stove bolt
  3. Machine bolt
  4. Spike
- 3-57. What type of bolt is either square necked, fin necked, or rib necked?
1. Carriage
  2. Stove
  3. Machine
  4. Toggle
- 3-58. Which of the following types of bolts has a machine thread with spring action, winghead nuts, and is particularly useful with sheetrock wall surfaces?
1. Molly
  2. Expansion
  3. Lag
  4. Toggle

3-59. Of the following types of adhesive, which has an asphalt, rubber, or resin base?

1. Glue only
2. Mastic only
3. Plastic only
4. All of the above



## ASSIGNMENT 4

Textbook Assignment: Chapter 4 - Fiber Line, Wire Rope, and Scaffolding  
Chapter 5 - Leveling and Grading

---

- 4-1. What kind of fiber is best for making fiber lines?
1. Hemp
  2. Sisal
  3. Manila
  4. Cotton
- 4-2. Number 1 manila rope is what color?
1. White
  2. Light brown
  3. Dark brown
  4. Black
- 4-3. Which of the following types of line is known for its strength, lightweight, and flexibility?
1. Nylon
  2. Hemp
  3. Manila
  4. Sisal
- 4-4. In line fabrication, opposite twisting of fibers prevents moisture from entering the line and keeps the fibers from unlaying under a load.
1. True
  2. False
- 4-5. What type of line is composed of four strands twisted together in a right-hand direction around a core?
1. Hawser-laid
  2. Shroud-laid
  3. Cable-laid
  4. Plain-laid
- 4-6. Which of the following factors is used to designate the size of small stuff?
1. Diameter
  2. Circumference
  3. Number of strands
  4. Number of threads per strand
- 4-7. Which of the following formulas should you use to find the approximate breaking strength (BS) of manila line?
1.  $BS = c^2 \times 900$
  2.  $BS = c^2 \times 2,400$
  3.  $BS = d^2 \times 900$
  4.  $BS = d^2 \times 2,400$
- 4-8. For which of the following reasons is a wide margin between the safe working load and the breaking strength of fiber line desirable?
1. To allow for the strain imposed only by jerky movements
  2. To allow for the strain imposed only when the line is bent over sheaves
  3. To allow for the strain imposed by jerky movements and when the line is bent over the sheaves
  4. To allow for the difference in the various types of fibers used
- 4-9. The SWL for a new fiber line can normally be increased by what percentage?
1. 10%
  2. 20%
  3. 30%
  4. 40%
- 4-10. A used fiber line in good condition has what safety factor figured in?
1. Eight
  2. Six
  3. Three
  4. Four

- 4-11. Of the following cleaners, which is the only one you should use to clean a muddy fiber line?
1. Water
  2. Kerosene
  3. Linseed oil
  4. Liquid soap
- 4-12. Which of the following wire rope sizes is most flexible?
1. 6 x 14
  2. 6 x 19
  3. 6 x 21
  4. 6 x 37
- 4-13. The size of wire rope is designated by what characteristic?
1. Circumference
  2. Diameter
  3. Weight per running foot
  4. Number of tires per strand
- 4-14. To measure the diameter of a wire rope, you should use which of the following methods?
1. Measure in one place near the middle
  2. Measure in two places near the middle, 10 feet apart; then average the results
  3. Measure in three places, 10 feet apart; then average the results
  4. Measure in three places, 5 feet apart; then average the results
- 4-15. What percentage of broken wires in a wire rope renders the rope unsafe for normal use?
1. 10%
  2. 8%
  3. 6%
  4. 4%
- 4-16. Rope is considered unsafe when its diameter is reduced to less than what percentage of its original size?
1. 10%
  2. 25%
  3. 50%
  4. 75%
- 4-17. The bitter end of a wire rope should extend what minimum distance below a wedge socket?
1. 6 in
  2. 2 in
  3. 3 in
  4. 4 in
- 4-18. What type of tackle system is an assembly of blocks in which more than one line is used?
1. Compound
  2. Double whip
  3. Simple
  4. Triblock
- 4-19. In a block-and-tackle assembly, the standing end of a line is attached to which of the following components?
1. Breech
  2. Becket
  3. Sheave
  4. Strap
- 4-20. Why are blocks used in a tackle assembly?
1. To change direction of pull only
  2. To provide a mechanical advantage only
  3. To change direction of pull and provide a mechanical advantage
  4. To provide an alternate means of using line
- 4-21. In a block and tackle, the opening in the block through which the line passes is known by which of the following terms?
1. Swallow
  2. Cheek
  3. Breach
  4. Frame

- 4-22. When selecting a block for use with fiber line, you should normally select a block of what approximate length?
1. 10 times the diameter of the line
  2. 2 times the circumference of the line
  3. 3 times the circumference of the line
  4. 4 times the diameter of the line
- 4-23. In the absence of a reference table, a rule of thumb for determining the diameter of a wire rope sheave is that the sheave should have what approximate diameter?
1. 10 times the diameter of the wire
  2. 20 times the diameter of the wire
  3. 3 times the circumference of the wire
  4. 4 times the circumference of the wire
- 4-24. What type of block can be installed at any point on a wire rope or fiber line without having to thread the rope or line through the block?
1. Swivel fairlead
  2. Swivel shackle
  3. Snatch
  4. Quick latch
- 4-25. When a snatch block is used in a rigging system, it provides what maximum number of mechanical advantages, if any?
1. One
  2. Two
  3. Three
  4. None
- 4-26. What is the simplest method of determining the mechanical advantage of any tackle?
1. Count the sheaves at the running block
  2. Determine the diameter of the sheaves
  3. Count the standing parts at the stationary block
  4. Count the number of parts of the fall at the running block
- 4-27. Hooks and shackles should be inspected at what minimum interval?
1. Daily
  2. Twice a week
  3. Weekly
  4. Monthly
- 4-28. When hoisting, what number of signalmen should be assigned?
1. One
  2. Two
  3. Three
  4. Four
- 4-29. When necessary the EMERGENCY STOP signal should be given by which of the following individuals?
1. The signalman only
  2. The crew leader only
  3. The project safety officer only
  4. Anyone who sees an emergency
- 4-30. What number of guy lines are required to operate shear legs?
1. One
  2. Two
  3. Three
  4. Four
- 4-31. What advantage does a tripod have over shear legs?
1. It is more stable only
  2. It requires no guy lines only
  3. It has greater load capacity only
  4. All of the above

- 4-32. Tripod legs should be spread no more than
1. one-third the length of the legs
  2. one-half the length of the legs
  3. two-thirds the length of the legs
  4. three-quarters the length of the legs
- 4-33. On a swinging scaffold, what are the minimum required sizes for (a) planks and (b) guard rails?
1. (a) 2 by 8ft (b) 1 by 4in
  2. (a) 2 by 4ft (b) 2 by 4in
  3. (a) 2 by 10ft (b) 2 by 8in
  4. (a) 2 by 8ft (b) 2 by 4in
- 4-34. When splicing a vertical pole, what minimum length splice plate should you use?
1. 6 ft
  2. 3 ft
  3. 8 ft
  4. 4 ft
- 4-35. Prefabricated scaffolding with 2 1/2 inch outside diameter steel tubing and post spacing not more than 6 1/2 feet apart is considered to be what duty?
1. Light
  2. Medium
  3. Heavy
  4. Extra heavy
- 4-36. To correct an engineer's level that is not quite horizontal, what action(s) should you take first?
1. Rotate the azimuth tangent screw
  2. Manipulate the focusing knob
  3. Release the azimuth clamp
  4. Slacken the reticle adjusting screws
- 4-37. You can bring the vertical cross hair of the dumpy level into exact alignment with the target by rotating which of the following components?
1. Leveling screws
  2. Leveling head
  3. Azimuth head
  4. Azimuth tangent screw
- 4-38. What type of level was designed to eliminate the use of the tubular spirit level?
1. Wye
  2. Dumpy
  3. Self-leveling
  4. Hand
- 4-39. A self-leveling level automatically gives a level line of sight when the level bubble is approximately within the center of the
1. tripod
  2. level
  3. bull's-eye
  4. cross hair
- 4-40. What type of level is used for short distance sighting and has no magnification device?
1. Hand
  2. Wye
  3. Automatic
  4. Dumpy
- 4-41. When removing a level from its case, you should grip what part?
1. The telescope
  2. The level bar
  3. The footplate
  4. The leveling plate
- 4-42. An engineering level should be stowed in its carrying case when not in use.
1. True
  2. False

- 4-43. In the target reading method of surveying, who reads the rod?
1. The chairman
  2. The instrumentman
  3. The flagman
  4. The rodman
- 4-44. On a Philadelphia rod, the large numerals indicating foot markings are in what color?
1. Red
  2. White
  3. Black
  4. Yellow
- 4-45. When the instrumentman is unable to read the foot markings on a Philadelphia rod, he gives the command RAISE THE RED. What should the rodman do?
1. Read the rod
  2. Lower the rod
  3. Raise the rod
  4. Wave the rod
- 4-46. On a Philadelphia rod, the vernier scale helps you make readings as small as what fraction of a foot?
1. 1/10
  2. 1/12
  3. 1/100
  4. 1/1,000
- 4-47. When the rodman finds it difficult to hold the rod perfectly plumb, it should be waved back and forth to allow the levelman to read the lowest reading touched by the crosshair.
1. True
  2. False
- 4-48. Differential leveling has what purpose?
1. Finding the line of sight between two points
  2. Finding the horizontal difference between two points
  3. Finding the vertical difference between two points
  4. Finding the radius of horizontal curves
- 4-49. The elevation of a proposed, artificially created surface is known by what term?
1. Plan grade
  2. Existing grade
  3. Gradient
  4. Line grade
- 4-50. On a plot plan, the grade elevation of a level horizontal surface is indicated in which of the following ways?
1. Solid contour lines
  2. Broken contour lines
  3. Evenly spaced contour lines
  4. Outlining the area and writing the elevation inside
- 4-51. Building corners should be laid out with reference to which of the following features?
1. A control base line
  2. Contour lines
  3. Batter boards
  4. Vertical control points
- 4-52. Batter boards have what function?
1. Protect stakes from being knocked over
  2. Prevent cave-ins at excavation corners
  3. Provide a means for reestablishing building lines when the stakes have been disturbed
  4. Mark the outside dimensions of excavations
- 4-53. Batter boards are used for both horizontal and vertical control in maintaining specific elevations.
1. True
  2. False

## ASSIGNMENT 5

Textbook Assignment: Chapter 6 - Concrete

---

- 5-1. What causes concrete to harden?
1. The active ingredients dry out
  2. The inert ingredients dry out
  3. The active ingredients combine chemically
  4. The inert ingredients combine chemically
- 5-2. Concrete has high ability to resist stretching, bending, and twisting.
1. True
  2. False
- 5-3. What principal factor controls the strength of concrete?
1. Dryness
  2. Water-cement ratio
  3. Age
  4. Reinforcement
- 5-4. The major factor controlling the durability of concrete is its strength.
1. True
  2. False
- 5-5. If more water is added to a concrete mix than is needed to hydrate the cement, the concrete becomes less
1. porous
  2. brittle
  3. fluid
  4. watertight
- 5-6. The production of good concrete is impossible unless good quality materials are used in the mix, and this mix is properly
1. cured and dried
  2. puddled and dried
  3. worked and cured
  4. fortified and cured
- 5-7. Portland cement is manufactured from finely ground limestone mixed with which of the following materials?
1. Clay
  2. Shale
  3. Marl
  4. Any of the above
- 5-8. For highway construction, Type III portland cement is sometimes preferred to type I because Type III has which of the following characteristics?
1. Finer finish
  2. Requires less working
  3. Shorter curing time
  4. Longer curing time
- 5-9. What type of cement was developed for use in areas subject to severe frost and ice conditions?
1. Air entrained
  2. Keene's
  3. Type V
  4. Type IV
- 5-10. Aggregate is the material combined with cement and water to make concrete.
1. True
  2. False
- 5-11. Concrete is denser and stronger when which of the following conditions is met?
1. All voids are filled
  2. Voids are large and unfilled
  3. Aggregate particles are not solidly bonded
  4. Aggregate particles are not coated with a cement-water paste

- 5-12. When performing a sieve analysis of aggregate, you should determine the percentage of material retained on the sieve.
1. True
  2. False
- 5-13. When a field test for cleanliness of aggregate shows 1/8 inch of sediment on a sample, the aggregate should be washed because this amount of sediment
1. decreases the workability of concrete
  2. prevents the aggregate from becoming friable
  3. may obstruct hydration and bonding of the cement to the aggregate
  4. will detract from the appearance of the concrete
- 5-14. To prevent aggregate from segregating during stockpiling, you should build up piles in layers by dumping successive loads alongside each other.
1. True
  2. False
- 5-15. In concrete, how is laitance produced?
1. Water collects under the surface of the cement
  2. Cement is hydrated with saltwater
  3. Cement is hydrated with minimum water
  4. Cement is hydrated with excess water
- 5-16. The proportion of air-entraining agent added to a concrete mix should fall within what range?
1. 1% to 2% only
  2. 1% to 3%
  3. 3% to 7%
  4. 8% to 10%
- 5-17. In concrete work, which of the following materials is a generally accepted accelerator?
1. Alkali salts
  2. Fly ash
  3. Calcium chloride
  4. Calcium carbonate
- 5-18. The accepted use for retarders is to increase the rate hydration.
1. True
  2. False
- 5-19. What is the main reason cement should be stored in a dry place?
1. To prevent it from becoming concrete while in storage
  2. To prevent it from setting too fast and producing weak concrete
  3. To prevent it from setting too slow and producing weak concrete
  4. To avoid warehouse pack
- 5-20. When storing sacks of cement in a warehouse, what is the main reason you should sack them close together?
1. So they can draw moisture from each other
  2. To restrict the circulation of air between them
  3. To prevent warehouse pack
  4. To prevent them from getting mixed up
- 5-21. Before using warehouse-packed cement, what should you do to make it lump free?
1. Restack the sacks to allow air to circulate around them
  2. Raise the temperature for 48 hours in the area where the sacks are stored
  3. Roll the sacks around
  4. Cover the sacks for 48 hours with tarpaulins

IN ANSWERING QUESTION 5-22 REFER TO  
TEXTBOOK TABLE 6-3.

- 5-22. Your specifications for a driveway call for a 3,000-psi concrete using 1-inch coarse aggregate. How many bags of cement per cubic yard of concrete will you need?
1. 8.4
  2. 7.1
  3. 6.5
  4. 5.8
- 5-23. In a field mix, the number of gallons of water per sack of cement must be increased to allow for the saturated surface-dry condition of the sand.
1. True
  2. False
- 5-24. When available aggregate is 1 1/2 inches, what rule-of-thumb should you use to calculate materials required for a proper concrete mix?
1. Rule 38 only
  2. Rule 41 only
  3. Rule 38 or 41 depending on whether mixing is done by hand or machine
  4. Rule 42

IN ANSWERING QUESTIONS 5-25 THROUGH 5-27,  
USE THE APPROPRIATE RULE OF THUMB FOR A  
1:2:5 CONCRETE MIX WHEN 2-INCH COARSE  
AGGERATE IS USED.

- 5-25. How many bags of cement are required to make 1 cubic yard of concrete?
1. 8
  2. 7 1/2
  3. 6
  4. 5 1/4
- 5-26. How many cubic feet of sand are required to make 1 cubic yard of concrete?
1. 5
  2. 7 1/2
  3. 10 1/2
  4. 12

- 5-27. To make 40 cubic yards of concrete, how many cubic feet of (a) sand and (b) coarse aggregate are required?
1. (a) 500 (b) 1,240
  2. (a) 480 (b) 1,200
  3. (a) 475 (b) 1,180
  4. (a) 420 (b) 1,050
- 5-28. To measure water for hand-mixing concrete, what size bucket should you use?
1. Half-gallon
  2. Gallon
  3. 10-quart
  4. 14-quart
- 5-29. Which of the following units is the most accurate way to measure aggregate?
1. Cubic feet
  2. Pounds
  3. Cubic yards
  4. Gallons
- 5-30. Concrete mixed with just enough water to completely hydrate the cement can negatively affect what concrete characteristic?
1. Tensile strength
  2. Workability
  3. Durability
  4. Compressive strength
- 5-31. For each layer of concrete placed in a mold for a slump test, how many times should you rod the mold?
1. 25
  2. 50
  3. 75
  4. 100
- 5-32. After completing a concrete slump test, you tap the side of the mix and the concrete crumbles apart. What condition exists?
1. Well-proportioned mix
  2. Undersanded mix
  3. Oversanded mix
  4. Fluid or runny mix



- 5-33. When incorrect concrete slump is detected, what action should you take to correct the problem?
1. Decrease or increase the aggregate only
  2. Change the proportions of the fine coarse aggregate only
  3. Either 1 or 2 above
  4. Add water to the batch
- 5-34. A mixture of only water and cement is commonly referred to as
1. mortar
  2. sand-cement grout
  3. neat-cement grout
  4. concrete
- 5-35. The rated capacity of a concrete mixing machine is determined by what factor?
1. The cubic feet of the mixed concrete
  2. The cubic feet of the dry ingredients
  3. The cubic yards of the dry ingredients
  4. The weight of the dry ingredients
- 5-36. In cement batch-plant operations, the aggregate must pass through a weigh box before being discharged into the mixer.
1. True
  2. False
- 5-37. You are to mix a 1:2:4 batch of concrete by hand. After putting part of the sand onto a mixing platform. in what order should you add and mix the other ingredients?
1. Cement, water, aggregate, sand
  2. Cement, sand, water, aggregate
  3. Aggregate, sand, cement, water
  4. Cement, sand, aggregate, water
- 5-38. In a 16-S concrete mixer, what maximum size aggregate can you use?
1. 3/4-in
  2. 1 1/2-in
  3. 3 -in
  4. 4 -in
- 5-39. In a 16-S concrete mixer, when should water be added to the mix?
1. Just before the cement
  2. Just before the sand
  3. Just before the aggregate
  4. After all the dry ingredients have been added
- 5-40. You are to charge the skip of a 16-S concrete mixer. In what order should you add the dry ingredients?
1. Cement, aggregate, sand
  2. Aggregate, cement, sand
  3. Sand, cement, aggregate
  4. Aggregate, sand, cement
- 5-41. When using a large mixing machine, what minimum time should you mix 2 1/3 cubic yards of concrete?
1. 1 min, 15 sec
  2. 1 min, 30 sec
  3. 2 min, 15 sec
  4. 2 min, 45 sec
- 5-42. It is now 12 noon and you just finished pouring concrete. You should make sure inside of the mixing drum is cleaned no later than
1. 1220
  2. 1230
  3. 1300
  4. 1330
- 5-43. When cleaning a mixing drum, you should place the coarse aggregate in the drum and turn for how long?
1. 5 min
  2. 10 min
  3. 15 min
  4. 30 min
- 5-44. When concrete must be discharged more than 4 feet above the level of placement, why should it be dumped into an elephant trunk?
1. To reduce segregation
  2. To prevent spattering
  3. To accurately place it
  4. To ensure workable consistency

- 5-45. It is now 12 noon and you begin mixing concrete in a mixing drum. The concrete should be dumped from the drum no later than what time?
1. 1230
  2. 1300
  3. 1330
  4. 1500
- 5-46. What type of concrete mixer can mix concrete en route to the jobsite?
1. Ready mixer
  2. Portable mixer
  3. Transit-mix truck
  4. Agitator truck
- 5-47. Compared to cast-in-place concrete panels, precast panels have what main advantage(s)?
1. Less forming material is required
  2. Placing the rebar is easier
  3. Thorough filling and vibrating are easier
  4. All of the above
- 5-48. Of the following surfaces, which is best for precast concrete?
1. Earth
  2. Wood
  3. Concrete
  4. Tile
- 5-49. At what point in concrete casting should the bond-breaking agent be applied to a casting surface?
1. Before the edge forms are placed
  2. After the edge forms are placed
  3. After the steel is placed but before final preparation
  4. Just before pouring the concrete
- 5-50. What is the simplest method for pickup of small cast panels?
1. 2 point
  2. 2 x 4 point
  3. 3 point
  4. 4 x 4 point
- 5-51. What is the most common type of brace used in tilt-up concrete construction?
1. Wood
  2. Cable
  3. Angle iron
  4. Tubular
- 5-52. Because of their flexibility and tendency to stretch, cable braces are unsuitable for most projects?
1. True
  2. False

## ASSIGNMENT 6

Textbook Assignment: Chapter 7 - Working with Concrete

---

- 6-1. In cast concrete, sand streaking is caused by
1. too rapid casting
  2. casting against earth surfaces
  3. escape of moisture from loose forms
  4. escape of mortar from hose forms
- 6-2. In building construction, what is the most common type of forming material?
1. Wood
  2. Earth
  3. Steel
  4. Fiberboard
- 6-3. What type of joint should you use to make watertight concrete forms?
1. Shiplap
  2. Tongue-and-groove
  3. square
  4. Rough-sawed
- 6-4. The hydrostatic head exerted on forms during concrete-placing operations normally continues for what maximum time?
1. 1 1/2 hr
  2. 6 hr
  3. 24 hr
  4. 72 hr
- 6-5. The parts of the substructure that distribute building loads to the ground are called
1. footings
  2. superstructure
  3. pier footings
  4. foundations
- 6-6. Footings for any foundation system should always be placed below the frost line.
1. True
  2. False
- 6-7. An exterior wall that serves as an enclosure and also transmits structural loads to the foundation is called
1. a pier
  2. a load hearing wall only
  3. a bearing wall only
  4. Both 2 and 3
- 6-8. Which of the following phrases best defines the term "keyway" in a concrete footer?
1. The rebar that sticks out of the concrete
  2. The 2-by-2 that goes across the forms
  3. The 45° groove around the outer edge of the footer
  4. The indentation in the center of the footer
- 6-9. Yokes are placed closer together at the bottom of column forms because
1. the yokes are easier to nail
  2. the bursting pressure is greater at the bottom
  3. you can stand on the yokes to work on the rest of the column
  4. the placing rate of concrete is very low
- 6-10. Horizontal form members that tie prefabricated panels together are called
1. studs
  2. shoe plates
  3. walers
  4. spreaders

- 6-11. Braces are not part of concrete form design and provide no additional strength?
1. True
  2. False
- 6-12. What type of form-tying device is used with cone nuts?
1. Tie wire
  2. Snap tie
  3. Shear tie
  4. Tie rod
- 6-13. When constructing stair forms, you should extend the platform what approximate distance past the sides?
1. 6 in
  2. 12 in
  3. 16 in
  4. 18 in
- 6-14. You are pouring concrete but a suitable bond-preventing compound is not available. To prevent the forms from bonding to the concrete, which of the following substances is a suitable alternative?
1. Wax
  2. Lacquer
  3. Marine engine oil
  4. Water
- 6-15. Of the following, which is the best bond breaking agent to use on steel forms?
1. Light-bodied petroleum oil
  2. Vegetable oil
  3. Marine engine oil
  4. Hydraulic oil
- 6-16. A light film of rust or mill scale is acceptable on rebar.
1. True
  2. False
- 6-17. Which of the following rebar ties should you use when a finished mat is to be lifted by crane?
1. Double-strand single tie
  2. Saddle tie
  3. Cross tie
  4. Saddle tie with a twist
- 6-18. Concrete footings should have what minimum concrete thickness between the ground and steel?
1. 6 in
  2. 8 in
  3. 3 in
  4. 4 in
- 6-19. Concrete walls exposed to weather should have what minimum thickness?
1. 1.5 in
  2. 2 in
  3. 3 in
  4. 4 in
- 6-20. In floor slabs, all steel reinforcing bars should be separated by what minimum distance?
1. 1 in
  2. 3/4 in
  3. A distance equal to 1 1/3 times the diameter of the largest bar
  4. A distance equal to 1 1/2 times the diameter of the smallest bar
- 6-21. When a column assembly of reinforcing bars is raised into place, the reinforcing steel is tied to the column form at intervals of
1. 5 ft
  2. 2 ft
  3. 3 ft
  4. 4 ft

- 6-22. Wood blocks can be used to hold beam reinforcing in place under which of the following conditions?
1. When wire stirrups are unavailable
  2. When precast blocks are unavailable
  3. When the construction is permanent
  4. When the concrete is protected from moisture
- 6-23. In footing construction, stones may be used instead of steel supports under reinforcing bars.
1. True
  2. False
- 6-24. A joint that separates a floor slab from a column is called
1. a contraction joint
  2. an expansion joint
  3. an isolation joint
  4. a stress joint
- 6-25. Control joints for interior slabs are typically cut to what depth?
1. 1 in
  2. 2 in
  3. 1/3 to 1/4 of the slab thickness
  4. 2/3 to 7/8 of the slab thickness
- 6-26. A tooled joint for a driveway should be spaced at intervals equal to the width of the slab but no more than what maximum distance?
1. 12 ft
  2. 16 ft
  3. 18 ft
  4. 20 ft
- 6-27. A joint that allows the transfer of part of the load from one structural element to another through the use of keys or dowels is called a
1. keyway
  2. tooled joint
  3. construction joint
  4. control joint
- 6-28. What type of blade is normally used to cut seasoned concrete?
1. Abrasive
  2. Diamond
  3. Graphite
  4. Carbide
- 6-29. High quality concrete requires both a well designed mix and good placing procedures.
1. True
  2. False
- 6-30. What is the maximum distance concrete should be dropped from a chute?
1. 5 ft
  2. 2.5 ft
  3. 3 ft
  4. 4 ft
- 6-31. What is the maximum concrete placing rate for a large pour?
1. 3 vertical ft every 30 min
  2. 4 vertical ft every 30 min
  3. 3 vertical ft per hr
  4. 4 vertical ft per hr
- 6-32. When placing concrete on a slope, you should start at what position?
1. Top only
  2. Bottom only
  3. Top or bottom
  4. Middle
- 6-33. What is the best tool for compacting concrete?
1. Spade
  2. Puddling stick
  3. Tamper
  4. Mechanical vibrator

- 6-34. When using a vibrator on air-entrained concrete, you should insert the vibrator into the concrete (a) what approximate distance for (b) what length of time?
1. (a) 6 in (b) 25 to 30 sec
  2. (a) 18 in (b) 5 to 10 sec
  3. (a) 24 in (b) 25 to 30 sec
  4. (a) 36 in (b) 5 to 10 sec
- 6-35. It is permissible to use a mechanical vibrator to move concrete in forms.
1. True
  2. False
- 6-36. Which of the following procedures is used to bring a concrete surface to the required elevation?
1. Consolidating
  2. Screedlng
  3. Floating
  4. Troweling
- 6-37. The speed at which a vibrating screed is pulled across concrete directly depends on which of the following factors?
1. The amount of concrete poured
  2. The density of the concrete
  3. The slump of the concrete
  4. The length of the beam
- 6-38. Troweling a vibrator screed finished floor slab is usually delayed because of the slow setup time needed for the concrete mix.
1. True
  2. False
- 6-39. Which of the following advantages results from edging concrete slabs?
1. Dressed corners
  2. Less corner chipping
  3. A finished appearance
  4. All of the shove
- 6-40. Which of the following finishing tools gives concrete a smooth, dense, finished surface?
1. Canvas belt
  2. Wooden float
  3. Steel trowel
  4. Aluminum float
- 6-41. Which of the following processes produces a nonskid or rough concrete surface?
1. Skidding
  2. Streaking
  3. Brooming
  4. Grinding
- 6-42. When a dustless, dense, easily cleaned floor is required, what finishing procedure should you use?
1. Sack rubbing
  2. Power troweling
  3. Steel troweling
  4. Grinding
- 6-43. When mortar is being used in rubbing a concrete surface, how long should the surface be kept moist to cure?
1. 8 hr
  2. 1 to 2 days
  3. 3 to 4 days
  4. 7 days
- 6-44. Concrete made with ordinary cement is generally cured for what minimum period?
1. 11 days
  2. 7 days
  3. 3 days
  4. 14 days
- 6-45. When curing flat surfaces, pending allows the concrete to maintain a uniform temperature.
1. True
  2. False

- 6-46. Which of the following materials is the best insulator?
1. Straw
  2. Moist earth
  3. Plastic film
  4. Dry insulation
- 6-47. When waterproof paper is used in the concrete curing process, what is the minimum overlap for adjacent sheets?
1. 12 in
  2. 8 in
  3. 16 in
  4. 4 in
- 6-48. Under ordinary circumstances, the forms for floor slabs can be removed after what minimum time?
1. 1 day
  2. 6 days
  3. 10 days
  4. 14 days
- 6-49. When patching concrete, you should apply mortar in layers NOT exceeding what maximum thickness?
1. 1 1/2 in
  2. 2 in
  3. 3/4 in
  4. 1/2 in
- 6-50. After forms are removed, a pressure gun may be used to repair which of the following defects?
1. Honeycomb
  2. Joints
  3. Tie-rod holes
  4. Rock pockets

## ASSIGNMENT 7

Textbook Assignment: Chapter 8 - Masonry

---

- 7-1. To smooth cut a concrete masonry unit, you should use which of the following tools?
1. A mason's hammer
  2. A brick chisel
  3. A brick trowel
  4. A pointing trowel
- 7-2. As a Builder, you should use a mason's hammer for which of the following tasks?
1. Smooth-cutting concrete masonry units
  2. Chipping and rough-cutting concrete masonry units
  3. Checking level courses
  4. Laying out corners
- 7-3. To finish a masonry joint, you should use which of the following tools?
1. Trowel
  2. Bolster
  3. Mortar board
  4. Jointer
- 7-4. When placing masonry units, you should use a steel square for which of the following jobs?
1. Leveling short columns
  2. Laying out corners
  3. Plumbing long stretches
  4. Finishing joints
- 7-5. There are three main types of concrete masonry units.
1. True
  2. False
- 7-6. Load-bearing concrete block used in above and below grade exterior walls that may or may not be exposed to moisture should be what grade?
1. M
  2. N
  3. O
  4. S
- 7-7. An 8-by-8-by-16-inch partition block is what actual size?
1. 8 by 8 by 16 in
  2. 7 3/4 by 7 3/4 by 15 3/4 in
  3. 7 5/8 by 7 5/8 by 15 7/8 in
  4. 8 by 7 5/8 by 16 in
- 7-8. A standard concrete masonry unit made with pumice has what approximate weight?
1. 20 to 30 lb
  2. 25 to 35 lb
  3. 35 to 45 lb
  4. 45 to 55 lb
- 7-9. The sides and the recessed ends of a concrete block are called the
1. shell
  2. face shell
  3. edge
  4. web
- 7-10. Spreading a 1-inch layer of mortar on both bed joints of walls and columns is called face shell mortar bedding.
1. True
  2. False
- 7-11. Excess sand in a mortar mix causes which of the following problems?
1. Slow setting
  2. Segregation
  3. Stickiness
  4. Lumps



- 7-12. For above grade exposed masonry where high compressive and lateral strength is not required, you should use what type of mortar?
1. M
  2. N
  3. O
  4. S
- 7-13. You should not temper mortar that has been mixed longer than what maximum time?
1. 1 hr
  2. 2 1/2 hr
  3. 3 hr
  4. 4 1/2 hr
- 7-14. What maximum proportion of calcium chloride should you add to mortar?
1. 1%
  2. 2%
  3. 3%
  4. 4%
- 7-15. A single course in a 10-ft-long block wall requires how many standard blocks?
1. 6 1/2
  2. 7 1/2
  3. 8 1/2
  4. 9 1/2
- 7-16. Using standard block, how many courses are required for a concrete block wall 10 feet high?
1. 14
  2. 15
  3. 16
  4. 17
- 7-17. To lay 600 square feet of wall, you need approximately how many (a) 8-by-4-by-12-inch concrete blocks and (b) cubic feet of mortar?
1. (a) 520 (b) 15
  2. (a) 680 (b) 15
  3. (a) 770 (b) 24
  4. (a) 900 (b) 24
- 7-18. Building specifications call for a 1:2 mortar mix. Using rule 38, how many sacks of cement are required to make up a 2-cubic yard mix?
1. 7
  2. 13
  3. 20
  4. 26
- 7-19. How many cubic feet of sand are required to complete a 1:2 mix for 2 cubic yards of mortar?
1. 26
  2. 51
  3. 52
  4. 104
- 7-20. When bags of cement or lime are stacked on pallets, a setback should begin at what tier?
1. Eighth
  2. sixth
  3. Fifth
  4. Fourth
- 7-21. You are constructing a concrete block wall. After the corners are located, what is the next step?
1. Spread and furrow the mortar bed for the first course
  2. Attach the guide strings to the corner stakes
  3. String out the blocks for the first course without mortar
  4. Position the corner block
- 7-22. A concrete block should be laid with what portion up?
1. The narrow end of the face shell
  2. The web facing
  3. The end shell
  4. The thicker end of the face shell
- 7-23. What part(s) of a block wall is/are laid immediately after the first course?
1. Corners
  2. Second course
  3. Lintels
  4. Lateral supports

- 7-24. You are building the corners of a concrete block wall. How should you ensure the horizontal blocks are correctly spaced?
1. Place a level horizontally across the corners of the block
  2. Place a level vertically across the corners of the block
  3. Place a level diagonally across the corners of the block
  4. Place a mason's line between the corners of the wall
- 7-25. During the construction of a concrete block wall, you must butter all vertical edges of a block at what point?
1. When the corner blocks are being placed
  2. When the closure block is being installed
  3. When all stretchers are placed
  4. When the second course is being laid
- 7-26. To ensure weathertight joints, at what point in construction should you start tooling mortar joints?
1. Immediately after laying each course
  2. As soon as the mortar becomes thumbprint hard
  3. After the excess mortar falls off the block
  4. At the end of the workday
- 7-27. Any excess mortar remaining on a concrete block after the joints are tooled should be removed by what method?
1. Rubbing with a burlap bag
  2. Flushing with water
  3. Striking the mortar with a small jointer
  4. Rubbing with a piece of broken concrete
- 7-28. The insertion of roofing felt in the end core of the concrete block in a control joint serves what purpose?
1. It permits the wall to move without cracking
  2. It eliminates bonding of the mortar on both sides of the joint
  3. It prevents raking of the outside block
  4. It eliminates bonding of the mortar on one side of the joint
- 7-29. Intersecting bearing walls should be tied together by what means?
1. Masonry bonds in alternate courses
  2. Hardware cloth placed across the courses
  3. Metal tie bars bent at right angles
  4. Anchor bolts located in alternate courses
- 7-30. Lintel blocks should extend past the edge of an opening to what minimum distance?
1. 6 in
  2. 12 in
  3. 16 in
  4. 20 in
- 7-31. When reinforcing a block wall, where should you place rebars?
1. At each corner
  2. At each side of a wall opening
  3. At points spaced no more than 32 inches on center in the wall
  4. All of the above
- 7-32. When reinforcing a block wall, you can ensure proper alignment of the rebar by performing what action?
1. Placing a cleanout block at every stud in all courses
  2. Pouring concrete as each course is laid
  3. Placing a cleanout block at every stud in the first course
  4. Pouring concrete around the rebar as it is placed

- 7-33. Weep holes in retaining walls are used to prevent water accumulation behind the wall.
1. True
  2. False
- 7-34. Modular U.S. brick are what nominal size?
1. 2 1/4 by 3 3/4 by 8 in
  2. 2 1/4 by 3 5/8 by 7 5/8 in
  3. 3 by 4 by 9 in
  4. 2 3/4 by 4 by 12in
- 7-35. The backing course for a cavity wall should be made with what type of brick?
1. Face
  2. Building
  3. Glazed
  4. Fire
- 7-36. Where cleanliness and ease of cleaning are necessary, what type of brick should you use?
1. Face
  2. Cored
  3. Glazed
  4. Sand-lime
- 7-37. To withstand high temperatures without cracking or decomposing, you should use what type of brick?
1. Cored
  2. Press
  3. Clinker
  4. Fire
- 7-38. When stacking brick, you should start tapering back when the pile reaches what minimum height?
1. 1 ft
  2. 2 ft
  3. 3 ft
  4. 4 ft
- 7-39. In masonry, a soldier is a row lock brick laid with its bed parallel to the face of the wall
1. True
  2. False
- 7-40. In brick walls, structural bonding takes place by what means?
1. Adhesion of grout to adjacent wythes of masonry
  2. Metal ties embedded in connecting joints
  3. Interlocking the masonry units
  4. All of the above
- 7-41. The pattern formed by the masonry units and mortar joints on the face of a wall is called what type of bond?
1. Stack
  2. Pattern
  3. English
  4. Running
- 7-42. Which of the following bonds is a variation of the running bond in which a header course appears at the fifth, sixth, or seventh course?
1. Running
  2. Flemish
  3. Common or American bond
  4. Dutch bond
- 7-43. You must place a three-quarter brick at the corner of each header course in which of the following pattern bonds?
1. Common
  2. English
  3. Block
  4. Stacked
- 7-44. An English bond pattern wall is composed of what alternate courses?
1. Three-quarter and blind headers
  2. Stretchers and bull headers
  3. Headers and stretchers
  4. Headers and rigid steel ties
- 7-45. To tie brick on the outside face of a wall to the backing course when no header courses are to be installed, what should you use?
1. Copings
  2. Metal ties
  3. Flashing
  4. Rebar

- 7-46. Moisture is prevented from seeping under a horizontal masonry surface by the installation of
1. sills
  2. copings
  3. parapets
  4. flashing
- 7-47. Water that accumulates on a flashing should be allowed to drain to the outside by what means?
1. Parapets
  2. Concealed flashing
  3. Weep holes
  4. Sills
- 7-48. To ensure a good bond between mortar and brick, you should avoid which of the following joints?
1. Slushed
  2. Bed
  3. Cross
  4. Header
- 7-49. You should spread bed joint mortar what maximum number of bricks ahead?
1. 5
  2. 7
  3. 9
  4. 11
- 7-50. For which of the following reasons should you should form a shallow furrow in the mortar of a bed joint?
1. To maintain the required width of brick spacing
  2. To conserve mortar
  3. To keep a gap from forming and allowing water to enter the wall
  4. To allow the mortar to dry slightly before placing the brick
- 7-51. To cut a brick to an exact line with a brick chisel or brick set you should follow which of the following procedures?
1. Break the brick with one blow of the hammer
  2. Let the straight side of the cutting edge face you
  3. Let the straight side of the cutting edge face the part of the brick that is to be saved
  4. All of the above
- 7-52. For weathertightness, what is the best type of joint finish?
1. Flush
  2. Bead
  3. Concave
  4. Weather
- 7-53. When laying out a brick arch, you can make the key brick line up by using an even number of bricks.
1. True
  2. False

## ASSIGNMENT 8

Textbook Assignment: Chapter 9 - Planning, Estimating, and Scheduling

---

- 8-1. The process of determining requirements, and devising and developing methods for constructing a project is called
1. estimating
  2. scheduling
  3. planning
  4. production standardization
- 8-2. Precise statements of quantities are what type of estimates?
1. Preliminary
  2. Detailed
  3. Activity
  4. Manpower
- 8-3. When using the *Seabee Planner's and Estimator's Handbook* for manpower estimates, a man-day unit is equal to what hour work day?
1. 7
  2. 7 1/2
  3. 8
  4. 10
- 8-4. The work schedule of a deployed Seabee battalion is based on an average of 65 hours per man per week.
1. True
  2. False
- 8-5. Which of the following types of labor is considered productive labor not contributing directly or Indirectly to the product?
1. Overhead
  2. Direct
  3. Indirect
  4. Manual
- 8-6. The individual who evaluates a job, has a working knowledge of all phases of construction, and can mentally picture separate operations of the project as it progresses is called the
1. scheduler
  2. estimator
  3. planner
  4. builder
- 8-7. The process of determining when an action must be taken and when material, equipment, and manpower are required is called
1. estimating
  2. planning
  3. scheduling
  4. coordination
- 8-8. What type of schedule is used to coordinate the manpower requirements of a project and show the number of personnel required for each activity?
1. Progress
  2. Equipment
  3. Material
  4. Manpower
- 8-9. When analyzing a project, scheduling always precedes planning.
1. True
  2. False
- 8-10. A project folder package contains what total number of individual folders?
1. 8
  2. 9
  3. 10
  4. 11

- 8-11. The right side of project file folder number 1 contains what information?
1. Predeployment visit summary
  2. Project scope sheet
  3. Level II
  4. Tasking letter
- 8-12. What project file folder contains information on all activities pertaining to the project?
1. 1
  2. 2
  3. 3
  4. 4
- 8-13. The right side of project file folder 5 contains the project bill of materials.
1. True
  2. False
- 8-14. The safety plan that you, as a Builder, develop is located (a) on what side of (b) what file folder?
1. (a) Left side  
(b) File folder 6
  2. (a) Left side  
(b) File folder 7
  3. (a) Right side  
(b) File folder 6
  4. (a) Right side  
(b) File folder 7
- 8-15. The left side of project file folder 9 contains the highlighted project specifications.
1. True
  2. False
- 8-16. When using blueprints, what section should you check to ensure changes were recorded?
1. Revisions
  2. Notes
  3. Specifications
  4. Construction drawings
- 8-17. On specifications, a list of unusual or unfamiliar items of work or materials is called
1. revisions
  2. quantity estimates
  3. notes
  4. statistics
- 8-18. What type of estimate is used as a basis for purchasing materials, and determining equipment and manpower requirements?
1. Activity
  2. Equipment
  3. Quantity
  4. Material
- 8-19. Which of the following procedures is the best way to check your estimates?
1. Have another person check the measurements
  2. Have another person make an independent estimate and compare the two
  3. Have another person initial the estimates as you complete them
  4. Have a crewmember sign the estimate
- 8-20. Which of the following problems can lead to omissions in your quantity estimates?
1. Failure to read all notes on drawings
  2. Errors in scaling
  3. Failure to allow for waste and loss of construction material
  4. All of the above
- 8-21. What should an experienced estimator do if he finds that details on a drawing are not drawn to scale?
1. Approximate the dimensions
  2. Use the same scale that was used elsewhere on the drawings
  3. Assume an approximate scale
  4. Obtain the dimensions from another source

- 8-22. Which of the following documents provides information for material, equipment, and manpower requirements?
1. Planning estimates
  2. Scheduling estimates
  3. Activity estimates
  4. Specifications and drawings
- 8-23. For estimating purposes, how should an activity be defined?
1. Single-task, single-trade
  2. Single-task, multi-trade
  3. Multi-task, multi-trade
  4. Multi-task, single-trade
- 8-24. When identifying an activity for an activity estimate, you must ensure that the
1. description is not complicated
  2. description includes all trades required to do the task
  3. manpower is available to accomplish the task
  4. description identifies a specific quantity of work
- 8-25. Material estimates have which of the following uses?
1. Procurement and determination of availability of materials
  2. Justification for and procurement of material
  3. Scheduling of equipment for projects
  4. Planning manpower needs
- 8-26. When estimating, which of the following forms should be used to list the required materials needed to complete each individual activity?
1. Bill of material
  2. Material takeoff
  3. Estimating worksheet
  4. Material estimate
- 8-27. Which of the following NAVFAC publications contains conversion and waste factors for construction materials?
1. P-405, App C
  2. P-437, Vol I
  3. P-458, Vol II
  4. DM-4.3
- 8-28. When ordering construction materials, long lead items are readily available through the supply system.
1. True
  2. False
- 8-29. The average rate of speed for a vehicle moving materials over roadways is computed by using what percentage of the posted speed limit?
1. 10% to 15%
  2. 20% to 30%
  3. 40% to 56%
  4. 60% to 76%
- 8-30. Where can an estimator locate information on the quantities and characteristics of construction equipment?
1. SAMM program
  2. NMCB TOA
  3. NAVFAC P-405
  4. NAVFAC P-437
- 8-31. Which of the following NAVFAC publications contains estimating information on common facilities and assemblies
1. P-349
  2. P-405
  3. P-437
  4. P-458
- 8-32. NAVFAC P-405, *Seabee Planner's and Estimator's Handbook*, defines a man-day as how many man-hours?
1. 6
  2. 8
  3. 10
  4. 12

- 8-33. The man-hour estimating tables in NAVFAC P-405 are arranged into how many divisions of work?
1. 10
  2. 12
  3. 14
  4. 16
- 8-34. CPA, CPM, and PERT are techniques used in the analysis of a flow of events and activities of a construction project. What is the generic title covering these techniques?
1. Network analysis
  2. Planning and estimating
  3. Flow charting
  4. Project analysis
- 8-35. A network remains constant throughout its duration and is a statement of logic and policy. Modifications of the policy are allowed.
1. True
  2. False
- 8-36. The sequencing of priorities among the activities making up a project can be represented by a/an
1. estimate
  2. network
  3. plan
  4. SAMM program
- 8-37. Placing underslab conduit runs before pouring concrete is considered what type of dependency?
1. Soft
  2. Continuing
  3. Flexible
  4. Hard
- 8-38. The basic concept behind precedence scheduling is known as
1. CPM
  2. PERT
  3. SAMM
  4. ADM
- 8-39. In precedence diagrams, how are activities represented?
1. An octagon box
  2. A rectangular box
  3. A start and finish node
  4. A round node
- 8-40. The general flow of a precedence diagram is represented by
1. an alphabetical sequence
  2. a numerical sequence
  3. arrows
  4. connectors
- 8-41. In a precedence diagram, what information about an activity can be found on the right side of an activity box?
1. The completion
  2. The start
  3. The man-hours
  4. The critical event
- 8-42. In a precedence diagram, activities may be divided into how many distinct groups?
1. One
  2. Two
  3. Three
  4. Four
- 8-43. In a precedence diagram, intermediate goals with no time duration relate to what kind of activities?
1. Working
  2. Milestone
  3. Critical
  4. Support
- 8-44. How are critical activities in a precedence diagram identified?
1. By arrows
  2. By slash marks through the activity box
  3. By a red circle around the activity
  4. By slash marks through the activity connector



- 8-45. Which of the following rules governs the drawing of a network?
1. Activities must be numbered in sequence
  2. The start of an activity must be linked to the ends of all completed activities before the start may take place
  3. Activities taking place at the same time must be linked before the start may take place
  4. Only critical path activities may be linked to each other
- 8-46. When two network activities are remote from each other but must be connected to show dependency, what type of connector should be used?
1. Direct
  2. Joining
  3. splitting
  4. Parallel
- 8-47. For what reason should you use a dummy event or focal activity in a network?
1. To simplify the network
  2. To show lead or lag
  3. To represent a delay
  4. To determine independent activities
- 8-48. In a network, what is the main objective of the forward pass?
1. To determine the number of activities
  2. To allow for material delays
  3. To establish the late start and late finish of each activity
  4. To determine the duration of the network
- 8-49. The longest path through a network is the critical path.
1. True
  2. False
- 8-50. What term identifies the amount of scheduled leeway allowed in a network?
1. Free play
  2. Allowance of time
  3. Float or slack
  4. Dead time or null time





